



GLOBAL WELLNESS
INSTITUTE™
EMPOWERING WELLNESS WORLDWIDE

GUIDE TO HYDROTHERMAL SPA & WELLNESS DEVELOPMENT STANDARDS

What You Need to Know Before Building Wet Areas

FOURTH EDITION

Guide to Hydrothermal Spa & Wellness Development Standards

What You Need to Know Before
Building Wet Areas

Cassandra Cavanah



**GLOBAL WELLNESS
INSTITUTE™**
EMPOWERING WELLNESS WORLDWIDE

© 2024 by Global Wellness Institute. All rights reserved.

ISBN 978-0-578-17820-2

No part of this book may be reproduced in any form without written permission of the copyright owners. All images in this book have been reproduced with the knowledge and prior consent of the owners and no responsibility is accepted by producer, publisher or printer for any infringement of copyright or otherwise, arising from the contents of this publication. Every effort has been made to ensure that credits accurately comply with information supplied.

First published in the United States of America by the Global Wellness Institute

333 S.E. 2nd Avenue, Suite 2045, Miami, FL 33131

www.globalwellnessinstitute.org

Disclaimer

The content of this book is for general information purposes only and has been obtained from many sources, professional organizations, manufacturers' literature and codes. The author and publisher have made every reasonable effort to ensure that this work is accurate and current, but do not warrant, and assume no liability for, the accuracy or completeness of the text or illustrations, or their fitness for any particular purpose. It is the responsibility of the users of this book to apply their professional knowledge to the content, to consult sources referenced, as appropriate, and to consult professionals for expert advice.

Editor: Cassandra Cavanah

Design and illustrations: Amy Detrick

Fourth Edition 04/2024

Third Edition 10/2018

Second Edition 10/2016

First Edition published 09/2014

Contents

Foreword	iii
Introduction	v
Chapter One: Overview of Hydrothermal Bathing	1
Chapter Two: Hydrothermal Wellness Benefits	13
Chapter Three: Project Planning:Architecture & Design	29
Chapter Four: Communal Thermal Bathing Areas	47
.....	
Saunas: Finnish Sauna, Russian Banya, Hybrid Sauna and Soft Sauna	55
.....	
Steam Room	69
.....	
Turkish Hamam/Moroccan Hammam	77
.....	
Relaxation Spaces: Laconium and Tepidarium	83
.....	
Wet Communal Cool Down: Rain & Drench Experiences and Foot Baths	89
.....	
Whole-Body Cold Immersion Therapies: Ice Room, Snow Room and Snow Shower	97

Chapter Five: Specialist Hydrothermal Treatments & Therapies	109
Specialist Rooms	114
Specialist Water Treatments	119
Specialist Beds/Tables	123
Chapter Six: Pool Areas – Function and Design	131
Lap/Exercise Pool	133
Hydrotherapy/Vitality Pool	134
Onsen Pool	136
Cold Plunge Pool	137
Specialty Pools: Floatation Pools; Watsu Pool; Mineral Pool; Kneipp Walk	138
Chapter Seven: Hot Springs & Geothermal Mineral Waters	157
Chapter Eight: Construction Materials and Building Services	177
Chapter Nine: Health, Safety and Hygiene	199
Chapter Ten: Sustainability and Regenerative Design	211
Glossary	221
Sponsors	225

Notice to Readers

Key terminology will be explained in the text. A glossary at the back of the book goes into further detail to help minimize confusion regarding the terms associated with modern hydrothermal spa areas. There will be references to building codes and other safety guidelines the global hydrotherapy industry follows, but these references are not exhaustive and you will need to consult your relevant local codes and guidelines.

Foreword



By Susie Ellis
Chairman and CEO
Global Wellness Institute

Decades in the spa and wellness industry have led to the good fortune of experiencing thousands of spas with hydrothermal traditions from every corner of the world. The journey has included smoky saunas in the forests of Finland, historic hamams in Turkey, hot Russian banyas, sweet-smelling mud baths in Italy, sizzling Ayurvedic steam cabins in India, and even the excitement of Arctic ice rooms in Las Vegas—to name a few. And I’ve loved each and every experience and have benefited from them both physically and mentally.

With extraordinary growth in the global spa/wellness industry—fueled by a rise in stress levels—these diverse experiences are becoming more important, and, fortunately, far more accessible.

However, building hydrothermal facilities entails major challenges. And, if not built right, there can be serious consequences. The design, the “fit,” the installation and the maintenance of all these experiences—from a steam room to a cold plunge pool—are unique and tricky. I’ve seen many “fails” firsthand: whirlpools where the jets hit me in all the wrong places; a burnt hand from door handles made out of materials clearly not designed for a hot, wet environment; steam room ceilings that drip, drip, drip as I try to relax. And, of course, there are the saunas or steam rooms that were too hot, too cold, smelly or moldy. I have faced dreaded “out of order” signs too many times to count.

Yet when done right, hydrothermal experiences can become the highlight of a spa's offering, with unrivaled wellness benefits that are difficult to achieve in any other way. And the bonus is that all the health benefits are self-administered so they can be achieved without high labor costs, making a dedicated hydrothermal area a great revenue booster. They are also the fundamental offering at new urban wellness clubs and bathhouses, which seem to be cropping up in cities around the world at a remarkable pace.

To build these diverse facilities correctly, precise technical knowledge is required: from material choice to complex drainage or electrical issues—this goes far beyond knowing which tiles can withstand high temperatures or what wood holds up best in a sauna. Too often wet area specialists are consulted in the later stages of a project—creating unnecessary costs and delays to correct the build.

That's why I'm so thrilled that you're holding the *Guide to Hydrothermal Spa & Wellness Development Standards* in your hands. It's designed to provide a 360-degree overview of what you need to know: from concepts and definitions; to how to assemble a project team; to design requirements for different types of hydrothermal experiences; to guidance on the correct building materials.

This guide is not written as a step-by-step manual for building hydrothermal experiences. Nor is it designed to cover all the standards and practices one must be familiar with—there are too many specific regional/national regulations to make that possible. Developers and operators will always require a wet area specialist/supplier, but this guide is the first—and only—resource to provide a universal bird's eye view of what all the players on the team need to know before embarking on one of these builds.

Because hydrothermal technology evolves rapidly, this book is updated often, incorporating new ideas, best practices and industry innovations. You are currently reading the 4th edition, published by the Global Wellness Institute's Hydrothermal Initiative, whose focus is to increase transparency and awareness in the design and implementation of all elements of spa and wellness facilities involving thermal and wet treatments.

This latest edition includes a primer on the evolution of new social wellness business models (Chapter 4), like urban bathhouses, refurbished hot springs resorts and longevity clinics, along with the communal bathing features to consider when planning these builds. You'll also find new/updated details on cold therapies, including ice rooms, snow rooms, cryotherapy and snow showers—plus so much more.

Many thanks go to the Initiative's members and the sponsors who support this important resource!

Susie Ellis

Chairman and CEO, Global Wellness Institute

Updated May 2024 for 4th edition

Introduction

As the popularity of spa and wellness continues to grow more people are seeking authentic ways to positively impact their long-term wellbeing. Hydrothermal bathing, with its benefits of improving the immune system, managing high blood pressure, detoxification and stress reduction (and so much more!) is one of the most ancient and proven wellness treatments available. This is driving a significant increase in installations both in residential and commercial builds.

The main objective of the *Guide to Hydrothermal Spa & Wellness Development Standards* is to provide the spa, architectural and interior design communities with distinct, up-to-date guidelines for the design and build of hydrothermal areas in public spas and private residences.

The goal is to provide readers—whether they be spa owners, consultants, developers, interior designers, architects, builders, professors, students or anyone embarking on the study or build of a hydrothermal facility—with a consistent and effective means to approach the planning and construction of these unique areas. More importantly, this guidance is also intended to help readers avoid costly mistakes.

In general, there are numerous design considerations, rules and codes to follow. In addition, there are specific building materials and technologies to consider. This handbook looks at all these areas, plus, common pitfalls and repeated mistakes that occur in the planning and building of hydrothermal bathing areas. And, of course, offers tips, tools and solutions for avoiding them.

The *Guide to Hydrothermal Spa & Wellness Development Standards* has the benefit of incorporating the accumulated experience of the leading practitioners in the modern spa industry. Spas around the world reflect the “good, the bad and the ugly” of hydrothermal design and implementations; by reading this book and using it as a reference, you are helping to make sure new builds include only the very best of hydrothermal spa standards.

This handbook is not designed as an exhaustive guide to a “model” hydrothermal build from beginning to end—you will need to employ specialist suppliers and/or consultants for this. It is, instead, a first step to familiarizing yourself with the key areas, understanding their functions and benefits and getting an overview that can guide you in your decision-making.

Members of the Global Wellness Institute Hydrothermal Initiative

Industry Praise

"This invaluable resource is the result of collaboration among experts drawing from extensive experience in wellness projects. I understand the critical importance of ensuring the right design and construction approach to these areas. Amid a resurgence in the popularity of bathing, sauna experiences, and self-guided thermal journeys in spas, this resource takes on heightened significance. It's a treasure trove of knowledge waiting to be explored."

Emlyn Brown, Global Senior Vice President of Wellbeing at ACCOR

"Hydrothermal communal bathing has long been important to Hilton's wellness offering and I know firsthand how challenging it can be to get these areas right. As a sponsor partner, we're delighted to contribute to the GWI's work to support excellence in design and function in this space."

Amanda Al-Masri, Vice President of Wellness, Hilton

"In the 40 years I have been designing spa and wellness destinations, one of the areas most prone to on-going maintenance problems and too-high capital costs, are the heat experiences and thermal areas. This book has been put together by those in the industry who understand these complexities and who have credibility and track record. It gives reassurance to developers, architects and designers who are not familiar with the technical expertise needed to deliver experiences which are now expected by well traveled consumers."

Sue Harmsworth MBE, Founder of ESPA International

"The beauty of this guide is that it addresses all aspects of these builds: including financial/business issues; design, development and construction; health and wellness benefits and even recommended guest usage for each experience. If a commitment to a hydrothermal area is made, it's imperative that experts are involved from the beginning of the project to ensure best results. WTS is thrilled to have this resource - it's a treasure trove of information and our whole team refers to it often."

Kim Matheson Shedrick, Senior Vice President, Arch Amenities

"This is a much-needed resource produced by hydrothermal veterans who really understand the challenges in building innovative hydro and thermal features. The wisdom in this book is hard-earned and we encourage anyone looking to build a hydrothermal area to utilize it to its fullest!"

Cary Collier and Doug Chambers, Principals of Blu Spas, Inc.

"The financial success of any hydrothermal project depends on its careful planning and preparation—and this is exactly what this guide helps readers achieve. The insight into the overall design, construction and use of these spaces is unparalleled."

Lynn Curry, President & Co-Owner, Resources For Leisure Assets USA

Contributors & Hydrothermal Experts

The Global Wellness Institute would like to thank the following companies for their contributions and support in making this guide come to life. Learn more about each of our sponsors on page 225.



BARR + WRAY



GHARIENIGROUP



TECHNOALPIN INDOOR





Chapter 1

Overview of Hydrothermal Bathing

In this book, we explore the world of hydrothermal spa bathing, also known as “aquathermal spa,” depending on the use of either the Greek or Latin root of “water.” Put simply, these are areas where people get either wet (hydro) and/or experience a change of temperature (thermal).

For thousands of years, different cultures have sought to harness the cleansing and healing power of water and heat—both considered luxuries in ancient times. Access to either was often difficult. This prompted more civilized societies throughout the world to find creative ways to deliver “hydro” and “thermal” to their citizens.

Often the easiest way to do this was through natural hot springs, areas that have always played a key role in hydrothermal bathing. The abundance of hot springs around the globe made it possible for many cultures to take advantage of these sites to construct dedicated buildings on or around them, prompting the concept of public bathing.

The geo-thermally warmed waters that bubbled up from the earth’s core not only served to cleanse its users, but “taking the waters” was also believed (and is now medically proven) to deliver minerals to improve certain skin conditions and relieve pain from arthritis and other musculoskeletal ailments. As far back as the 7th century B.C., there are mentions of a “spring which contains sulfur to treat disease” in Chinese history books.

Private bathing areas were virtually unheard of in ancient times, so the most efficient means for washing was to gather in these public bathing spaces. Perhaps the best known and most cited examples of public bathing houses come from the Romans—their advanced technology and grandiose architecture (not to mention their geographical

Hydrothermal bathing has been practiced for thousands of years. The pools at Bath Spa, UK.



Photo by Nik Koenig

The inhabitants of Northern Europe invented the sauna. Sauna at the Faena Hotel, Miami Beach.

domination of Europe and Asia) positioned them as forerunners in hydrothermal bathing. But there are plenty of other cultures that also take credit for the invention of some of today's popular hydrothermal applications.

For example, a highly popular and long enduring hydrothermal treatment is the Finnish sauna. With heat being such a prized resource in freezing Finland, the Finns devised a means to heat a wooden cabin to the highest degrees, causing the occupants to become very hot. Leaving the cabin, sweating profusely, they then used the snow outside to wipe off the sweat and dirt—and repeated the process as many times as the need to be clean dictated. This is why, even today, the Finns typically take a “roll in snow” after bathing in the sauna. The practical reason for diving into the snow is because running water was in short supply during the frozen winters of the north. But the result is a cleansing/detoxifying ritual that is valued to this day and has been proven to improve the immune system and reduce blood pressure.

It should be noted that though Finland is often recognized as the birthplace of the sauna, the whole of the frozen northern Europe was known to have invented similar forms of bathing—for example, the Russian banya is almost identical in design and purpose.

In Eastern Europe, the Jewish people have had a tradition of sweating for their health that goes back more than 2,000 years. There are even frequent mentions of bathhouses in the Talmud, the religious authority for traditional Judaism. Known as taking the ‘shvitz,’ the practice was originally adopted by Russian Jews in Russian banyas and was popular with Jewish immigrants in America during the 1920s. Also popular with orthodox Jewish men and women is the ‘mikvah,’ which literally translates as ‘a gathering or collection of water’. This water served to ceremonially clean people prior to entering the temple and ultimately became a basis for the ritual immersion of baptism.

Today, mikvahs are not only built in a communal setting, but also constructed in private homes. There are some specifics for constructing mikvahs—they must be below ground and cannot be portable. A mikvah must have contact with natural water, so mikvahs constructed in modern homes will normally have one primary pool filled with tap water and used for immersion, and a secondary pool where rainwater or water from some other natural source is collected. A hole between the two pools will allow the water to mix, thus rendering the primary pool fit for ceremonial cleansing. Each Jewish sect has different practices regarding the use of a mikvah, but the theme of spiritual purification and cleansing is common to all of them.

On the American continent, there is early evidence of “sweating” as a form of cleansing, including the use of aromatic herbs and flowers (or “aromatherapy,” as it’s known today). The Aztec tribes were particularly influential in their creation of two-story wattle-and-daub sweat rooms. In Mexico, the temazcal or “sweat lodge” is another example of thermal bathing; today, you can visit an excellent example of a Mayan steam room at the Chechen Itza site in the Mexican Yucatan Peninsula.

During the 16th century, the Ottoman Empire gave rise to the now-famous hamam (or Turkish bath). There is evidence, however, to show this form of bathing predates the Ottomans and was used widely in North Africa and the Middle East even prior to the rise of Islam. Once again using sweating as a form of cleansing, the traditional hamam became particularly popular before a visit to the mosque. The old hamams of Istanbul boast beautiful interiors including fantastic examples of traditional Muslim ceramic and mosaic art with inscriptions from the Koran often being present on the walls. You can also find fine examples of hamams in Syria, Lebanon, Jordan, Tunisia, Libya, Algeria and Morocco. Note: The Turkish hamam has a single central “m,” while the Moroccan hammam is spelled with two.



Turkish hamams feature a heated belly stone (gobek tasi) as their centerpiece. This is where the traditional soap massage takes place.

Japan is also known for its extensive bathing culture with an ethic of cleanliness rooted deep in its culture. As early as the 3rd century, references to the Japanese habits of cleanliness appeared in writings. In the 6th and 7th centuries, the rise of Confucianism and Buddhism further solidified the virtues of cleanliness and the appreciation for the ritual of bathing. Japan's more than 20,000 natural hot springs formed the original onsens. The Japanese also developed a form of steam bath called the sento, a type of vapor bath that used aromatherapy elements and included body scrubbing. And, finally, the furo is a bath made of wood long enough for the bather to lie flat; it's often found in private homes.

Another type of thermal bathing—mud bathing— originated in the Middle East thousands of years ago. This form of bathing wasn't necessarily devised to “cleanse the masses,” but, instead, was a medicinal and beautifying ritual using the mineral-rich silt of the Dead Sea to treat skin conditions. Similarly, the Ancient Egyptians valued the healing powers of the mud of the Nile delta, which delivered minerals and deposits from the high mountain ranges of Ethiopia.

And then in the 1900s, the French began harnessing the restorative properties of the sea—which is rich not only in sodium chloride (salt) but also minerals and trace elements. Known as “thalassotherapy,” treatments evolved to use warm seawater to allow the minerals to pass through the skin, complemented by algae, seaweed and alluvial mud applications.

Japan is known for its extensive bathing culture; an onsen at Hoshino Resorts Co., Ltd. In Hakone, Japan.



Hydrothermal Experiences from Hot to Cold



Experience	Celsius	Fahrenheit	Humidity
Russian Banya	80 to 90	176 to 194	35-40%
Event Sauna	80 to 90	176 to 194	10-30%
Finnish Sauna	70 to 105	158 to 221	10-20%
Finnish Sauna to US Codes	70 to 90	158 to 194	10-20%
Soft Sauna	50 to 70	122 to 158	65%
Steam Room	43 to 48	110 to 118	100%
Hamam/Hammam	38 to 40	100 to 104	90%
Infrared Therapy Room	35	95	55%
Relaxation Space (Laconium/Tepidarium)	30	86	55%
Average Domestic Living Room	23 to 25	73 to 77	55%
Ice Bath	10 to 15	50 to 60	N/A
Cold Plunge Pools	8 to 12	46 to 53	N/A
Ice Room	5 to 10	40 to 50	35%
Ice Hole in Sea or Unfrozen Sea/Lake Water	4	39	N/A
Snow Room	-10 to 0	14 to 32	25%
Cryotherapy Chamber	-110 to -140	-166 to -220	30-40%

Benefits of Hydrothermal Experiences

So the origin of hamams, saunas, onsens, etc., ultimately derived from the need to cleanse the body. However, there are now recognized health and aesthetic benefits associated with all forms of hydrothermal bathing. In recent years, medical science has explored the effects the immersion in hot temperatures, and the subsequent transfer to cold, has on the body—and have determined that a key benefit of such temperature change is detoxification. Getting hot and sweating out impurities is important to our health, and experiencing extreme changes in body temperature also increases the circulation and gives the body functions a positive jolt. The importance of thermal bathing, and the pleasure derived from it, is undisputed and well-recorded over the centuries, but it has only really been in the last 200 years or so that the medical profession has looked into the physical benefits, rather than just the ability to cleanse. In particular, there are multiple medical studies that confirm the reduction of hypertension with use of saunas. Evidence-based studies can be found at www.wellnessevidence.com, a portal designed to help people explore studies that have been done on common wellness therapies. Although not scientifically proven at the time, the effect of the heat, and the minerals, along with the social aspect of communal bathing and the hygiene benefits that resulted, combined to create almost miraculous results. Even fertility was seemingly improved—in the 1700s, Queen Mary “took the waters” at the thermal springs in Bath, England while apparently suffering from infertility and 10 months later gave birth to a son.



Roman Baths, Caesar's Palace, Las Vegas, Nevada, U.S.

In addition to the medical benefits, there is the simple notion of “thermal pleasure”—the feeling a person experiences when moving from a place where the temperatures have eventually made them uncomfortable to one where the contrasting temperature brings immediate relief and an almost euphoric feeling of pleasure. Hydrothermal spa areas provide this pleasure while delivering a social and ritualistic experience.

In the modern world, public bathing has evolved from being a necessity (i.e., the only way to cleanse the masses) to a ritual (and often a private one) that not only helps purify the body, but also one that gives us a chance to take a break from our busy, stressful lifestyles—allowing for complete and utter relaxation.

Modernization of Hydrothermal Spa Bathing

What is a “spa” anyway? Many think the term originates from the Latin “sanus per aquam,” which translates into “health through water,” while many Europeans associate the word with old European spa towns where natural springs, hot or cold, saline or sulfuric, produce endless quantities of natural water. Britons of the Victorian era were famous for traveling widely to “take the waters” of spa towns throughout Europe, which were believed to have medicinal or healing powers. Another suggestion is that the term “spa” comes specifically from another famous bathing site of the same name: “Spa” in Belgium.

Many of the now-famous European spa towns were put on the map over two thousand years ago during the Roman invasion of Europe, when the Romans brought their already advanced bathing culture to the lands they conquered. For example, Emperor Caracalla believed the hot springs of Baden-Baden in Germany cured his arthritis, and he consequently built one of the finest bathing houses outside Rome in this location.

It has often been said that a visit to a spa should be a journey of discovery—not just of new experiences, but a discovery of the joy of true relaxation and of self-indulgence. Spa and hotel developers, as well as homeowners, are realizing more and more that this journey can be significantly enhanced with the addition of hydrothermal experiences.

The ability to rest in the intense warmth of the sauna, to enjoy the benefits of steam bathing or salt inhalation, to exhilarate in a cold plunge, to refresh in the more gentle, cooling atmosphere of a snow cavern, and to invigorate with dips in specially designed hydrotherapy pools without the worry of time, is perhaps the ultimate in relaxation.

And, if between these experiences you can relax in comfort, either in silent relaxation spaces or, more sociably, on heated loungers that may surround a hydrotherapy pool, the experience is enhanced.

Overview of Popular Hydrothermal Experiences

This section provides a brief overview of the areas seen most frequently in both commercial and residential builds, from the hottest to the coolest space.

Sauna

Page 54



Barr + Wray Ltd.

A simple timber cabin with a heat source radiating warmth from the wood-clad walls via heated stones, warmed by electricity or gas, but traditionally by log fires, and normally operating between 70°C to 100°C (158°F to 212°F). Many styles are available, but the sauna has undergone substantial modernization as it has been brought inside spa buildings (versus being an independent external building) to form part of a hydrothermal bathing suite.

Russian Banya

Page 63



World Spa

The term is commonly used to refer to the sauna-like room found in a Russian bathhouse. It's almost identical to a sauna in design and purpose, however, it can have higher temperatures and humidity. Bathers are also encouraged to hit themselves and/or others with “veniks” (bunches of dried branches and leaves) to help improve circulation. In addition, there will usually be an antechamber next to the banya for socializing, playing games and enjoying refreshments.

Infrared Therapy Cabin

Page 116



Infrared therapy rooms are also mild (approximately 40°C to 60°C or around 90°F to 105°F) in comparison and have no humidity, so feel cooler than a soft sauna. These rooms contain lamps/heating elements that emit infrared light which, when absorbed, produces a gentle warmth that helps to increase body temperature. Infrared therapy has grown in popularity in recent years and is believed to relieve pain in muscles and tissues.

Steam Bath or Steam Room

Page 68



Steam baths (or steam rooms) are typically tiled or stone rooms reaching temperatures of between 42°C to 48°C (110°F to 118°F) with 100% humidity provided by hot steam, which can either be created from heated waters in the room itself or, more commonly, pumped into the room using a steam generator. Aromatic extracts of essential oils can be injected concurrently to give the steam bath an added sensory element.

Hamam or Hammam

Page 76



Modern hamams are normally larger than a steam room and a Turkish hamam will have a heated “göbek tasi,” or, literally, “belly stone,” as its centerpiece. A smaller replica located in an adjacent room enables bathers to receive a soap massage in private. The heated floor, walls and benches warm the room to 38°C to 40°C (100°F to 104°F) with up to 90% humidity from an independent steam source.

Relaxation Spaces

Page 82



Fitted with a range of beds and loungers, these spaces are essential. When allocating relaxation space, consider that it takes at least 20 minutes for a bather's body temperature to equalize, which is the only time he/she should return to a warm/hot cabin or pool. Logically, there must be at least as many seats/loungers as there are total places in the thermal cabins and pools. The loungers in these rooms are often ceramic, providing long-wave infrared-C that help the body relax.

Halotherapy/Salt Room

Page 114



The only way to truly benefit from salt is via inhalation (meaning those beautiful Himalayan salt walls are for aesthetics only). This practice is known as “halotherapy” and is a proven method for cleansing respiratory passageways and promoting long-lasting lung health. For a salt room to be effective, finely powdered salt must be introduced into the air via a halo generator or by nebulizing brine vapor. Salt therapy is said to relieve asthma, improve circulation and even lower blood pressure.

Vitality Pool

Page 134



A vitality pool is the generic name for what people commonly refer to as a hot tub or “Jacuzzi” (the brand name that has become synonymous with pools with water jets). Vitality pools offer a mini-hydrotherapy experience and are typically used where space will not permit the inclusion of a full-size hydrotherapy pool. These pools typically operate at 35°C to 38°C (95°F to 100°F) and will have underwater pressurized air and water features.

Cold Plunge Pool

Page 137



Aurelio Hotel & Chalet Lech

Traditional cold-water pools stem from the Romans who realized that the surge of blood, caused by contracting blood vessels, which had previously expanded in the hot rooms, was a particularly invigorating experience. Purists would have it that a plunge pool should be barely above freezing point, hence the current fascination with ice baths, but temperatures of 5°C to 10°C (41°F to 50°F) are effective.

Foot Bath

Page 95



Sommerhuber

The foot bath area should provide warm ceramic or mosaic benches to relax, socialize and be comfortable while bathing the feet in cool or warm (never hot) water. Feet are especially important in the heating and cooling process of a hydrothermal journey because the small amount of flesh and fat on them, combined with the large number of blood vessels, helps cool or warm the bloodstream quickly.

Rain and Drench Experiences

Page 90



Dornbracht International

Cold waterfalls, mists, and body jets combined with aroma, sound and visual effects help take the bather to another world, while a deluge of cold water will snap them right back into the present, cooling the body down for another round of heat therapy. Another cooling option is a gentle, refreshing rainfall-like spray of water on the body as a bather walks through it.



Cold rooms are typically chilled to around 6°C to 12°C (43°F to 54°F) or sometimes even lower. Here you might find an ice machine or a snow shower. The benefit of a cold room versus a snow room is that they take less space and energy to run. The features only require energy when a guest pushes the button to activate snow or ice delivery on demand.



There is nothing more exhilarating than stepping from a traditional sauna into a landscape covered with a fresh fall of real snow to cool the body. Operating at -15°C to 0°C (5°F to 32°F), the dry, cold temperatures of a snow room is much more gentle than the freezing wet temperatures of a cold plunge. A snow shower offers an alternative, providing snowfall at the push of a button.



An ice fountain is often located at points around the spa for quick access to a cool down or in dedicated a cold room/frigidarium. The ice particles (crushed, flake or slushed ice) can be applied to selectively to cool the extremities of the body, such as legs and arms. The very cold ice reaches temperatures far below 0°C (32°F) and the process of rubbing the snow onto arms and legs assists cooling in those areas.



Chapter 2

Hydrothermal Wellness Benefits

The benefits of heat and water can be enhanced with the addition of restorative-promoting minerals infused or naturally occurring in the waters or externally applied muds and creams; while aromatherapy, which incorporates all our senses, delivers further restorative and calming benefits.

For centuries, hydrothermal treatments have been recommended in the treatment of certain medical issues and ailments. Today, there is mounting medical evidence that supports the use of hydrothermal therapies for treating a wide range of medical conditions—including common ailments like arthritis, sports injuries, chronic pain, and cardiac disease. This chapter offers a primer on the wellness benefits behind many of today’s hydrothermal treatments—whether hot, cold, wet or muddy—and directs readers to additional resources for further research.

As noted throughout this guide, the healing powers of water and heat have been harnessed throughout the ages to provide physical solace, comfort, healing and, of course, simply bathing. Even as far back as 339 BC, history notes that some Roman baths were specifically used for healing purposes and people visited them to help with rheumatic diseases, paralysis and injury recovery. And, of course, the people of the Nordic countries have a long tradition of hot and cold contrast therapy—using the hot, dry heat of saunas in combination with a freezing “roll in the snow”—has been shown to promote heart health, detoxification and even reduce blood pressure.

Medical Evidence for Hydrotherapy

Hydrotherapy, using water and heat together to treat conditions, relieve pain and increase muscular power and a range of joint movement, has been a mainstay of managing many medical conditions. These include arthritis, neurological conditions and rehabilitation from sports injuries. Mark Liponis, M.D., Chief Medical Officer at Canyon Ranch (Lenox, MA, USA), observes that the wide-ranging health and well-being benefits of hydrotherapy include: general relaxation; counteraction of gravity and a creation of buoyancy; fluid dynamics for bodywork/massage/rehabilitation; water's unique molecular and electric healing properties; water's ability to deliver healing additives, such as magnesium salts, sulfur compounds, radiation (radon); and "floatation" or sensory deprivation tanks for mental health/relief of anxiety/depression, etc.

Dr. David Marshall, a specialist physician in rheumatology and professor at University of Glasgow, has reviewed and catalogued more than 300 research papers and articles identifying the benefits of hydrotherapy on these conditions:

1. Arthritis
2. Chronic pain conditions
3. Diseases of the nervous system
4. Cardiac disease
5. Respiratory disease
6. Miscellaneous, including obstetric care, immunology, dermatology and sports medicine

Hydrothermal and Physical Therapy

According to the aforementioned white paper, the physical benefits of using water in therapeutic exercises can be attributed to four main properties: heat transfer, Archimedes forces, hydrostatic pressure and sensory input.

In addition to reducing pain, hydrotherapy can be used to specifically improve:

- Strength and/or prevent muscle wastage
- Posture, flexibility and/or prevention of contracture (shortening and hardening of muscles, tendons or other tissue)
- Ability to perform normal everyday activities, including walking
- Exercise and work tolerance
- Cardiovascular fitness
- Balance and reaction times

Heat Transfer

When a body is immersed in water at a temperature greater than 36°C to 40°C (96.8°F to 104°F), heat transfer occurs from the water to the body. This leads to cutaneous vasodilation with heating of the blood circulating under the skin. Arterial blood pressure drops due to this vasodilation. Evaporation of the sweat produced as a result of this increase in temperature is impossible below the surface of the water. The core temperature therefore rises. Immersion at temperatures below 40°C (104°F) leads to stimulation of warm receptors. This leads to inhibition of the activity of motor neurons, which leads to muscle relaxation. An increase in the superficial tissue temperature creates a palliative effect and pain reduction may be experienced. If the immersed individual exercises, body temperature will increase even further.

Archimedes Forces

Archimedes' principle states that when a body is wholly or partially immersed in a fluid, it experiences an upthrust equal to the weight of the fluid displaced.

This upthrust is what we call "buoyancy," and is the force that counteracts gravity, supporting the body in water. The more of the body that is immersed, the more buoyancy there is and weight bearing is further reduced. The reduction in weight bearing leads to relief from compressive forces on painful weight bearing joints.

Therefore, someone who generally suffers pain in their back or legs when standing or walking will find those activities much less painful under water. Indeed, such individuals may well be able to exercise to aerobic levels in water. Buoyancy can also promote an increase in movement where there is muscle weakness and be used to develop a graded program of exercises, the easiest of which would be buoyancy-assisted, moving to buoyancy-eliminated (harder) and progressing to buoyancy-resisted (hardest).

Hydrostatic Pressure

Pascal's Law states that fluid pressure is exerted equally on all surfaces of an immersed body at a given depth. Pressure increases as depth increases. This principle can be used therapeutically to help reduce edema and lower limb swelling (by exercising at greater depths). Hydrostatic pressure can restrict chest wall expansion, a factor important in those with reduced pulmonary function this should be taken into account. Hydrostatic pressure may be used in a progressive resistive exercise program in such individuals.

Sensory Input

In water there may be less fear of falling as the water provides support and stability. It is much less traumatic to fall into a compliant medium (water) than on a noncompliant one (ground). A less anxious person may be happier to challenge their body and, therefore, develop their balance and movement skills.

An immersed body will move more slowly as the viscous medium retards movement and sensory awareness may be increased by moving through a more viscous medium (water) compared to a less viscous medium (air). If a person moves quickly through water they produce drag or turbulence. This is another resistive force and can again be used therapeutically, for further muscle strengthening.



Courtesy of Sportresidenz Zillertal (KLAFS)

By Dr. Mark Timmerman

Dr. Mark Timmerman is a Family Physician and Sports Medicine Specialist in Wisconsin, USA. He has a wood heated sauna in his home and takes a sauna at least three times each week.

Health Benefits of Sauna

The use of heat while bathing has been an integral part of many cultures for centuries. Finland is well known as a society of avid users of the sauna, which usually produces a relatively dry heat between 70°C to 105°C (158°F to 212°F). The traditional Finnish sauna is a smoke sauna (“savusauna”) where stones are heated with a fire for several hours and then the sauna is taken after much of the smoke has cleared from the sauna building. More commonly today, saunas are heated by stoves using wood, gas or electricity, and water is used intermittently on the stones to produce steam.

Other cultures known for their heat bathing traditions include Russia (Banya), Lithuania (Pirtis), Sweden (Bastu), and Turkey (Hammam). In the United States, the American Indians traditionally have used sweat lodges for spiritual ceremony. The rest of American sauna culture has been influenced by European immigration during the late 1800’s and early 1900’s. In my own case, for instance, I grew up in a northern Minnesotan town where many Finns immigrated in order to work in iron ore mines. Many of us therefore had saunas in our basements or at our lake cabins.

Sauna bathing usually involves several repetitions of alternating heat with cold, such as 15-20 minute heat exposures interrupted by dipping in a pond, taking a cool shower, or sitting outside. In some cultures, oak or birch twigs and leaves and/or steam are used to provide a more intense heating and massaging experience.

Health Benefits

There are many myths regarding the physiological and psychological affects of sauna bathing. Unfortunately, we lack sufficient large, controlled studies in the medical literature to help fully understand the science supporting these myths. We have learned a significant amount about the physiologic adaptations of the body to heat bathing, however, and there is a growing body of scientific study, especially from Germany and Finland, to help understand the real benefits and risks of the practice.

Physiologic Response

Essentially, the effects of heat bathing are the body's way to deal with heat stress. In other words, heat exposure causes a person's physiology to react to that form of stress out of self-defense in order to prevent injury. The systemic adaptations that occur over time can indeed make a person stronger, similar to adaptations to regular exercise.

Initially, as the body is exposed to the heat of a sauna, the skin temperature increases. As a way to dissipate the heat and protect the internal organs, the body decreases blood flow to those organs and increases circulation to the skin. In addition, sweat glands are stimulated in order to allow for evaporation and further cooling effect.

Because the blood volume to the periphery and skin is increased, the heart rate must also increase so that the internal blood pressure can be maintained. While the overall work of the heart does not change significantly, the pulse can increase up to double the normal rate.

Breathing becomes more rapid and shallow in the sauna, and the overall flow rate and lung capacity increases, suggesting more efficient pulmonary ventilation and allowing for additional heat dissipation.

The sympathetic nervous system is also stimulated as skin temperature rises, causing a "flight or fight" response. Stimulation of the hypothalamus and pituitary glands in the brain, which communicate with the adrenal glands near the kidneys, causes release of cortisol ("adrenaline"), creating a heightened sense of alertness, reduced perception of pain, and elevated mood. Interestingly, when a sauna is followed by a plunge into cold water, this adrenaline response is elevated even more.

Cardiovascular Benefits

There is good scientific data to support the beneficial effects of repeated sauna exposure for the heart. In particular, a person's resting systolic blood pressure can decrease as much as 10 points after just three 20 minute sauna sessions several days apart. Some studies have found up to a 20-point systolic blood pressure decrease with regular sauna exposure (such as twice per week) over a several month period.

Congestive heart failure, which is related to poor pump function of the heart, has also been shown to benefit from regular sauna exposure. Both symptoms and heart rhythm abnormalities improve predictably with regular sauna use.

Importantly, because the workload on the heart is generally not increased in the sauna, the risk of myocardial infarction ("heart attack") in the general population is not higher during sauna bathing. While it is usually recommended that a person who has had a

cardiac event or procedure should wait at least 6 weeks before going back to sauna bathing, it is considered to be safe practice for people with heart disease.

Training Effect

Because many of the body's adaptations to sauna are similar to its response to exercise, many people wonder if taking a sauna can improve cardiovascular fitness. While one recent study has suggested that endurance performance does improve for runners who recover in the sauna after training, in general one's fitness does not improve with routine sauna bathing alone.

With regular sauna bathing, however, the body does adapt to heat stress, so that one can tolerate longer and hotter sauna exposures without injury. People who are new to saunas are therefore encouraged to moderate their heat exposure by limiting their time in the sauna, or by sitting on a lower bench. In addition, athletes who use the sauna routinely are able to exercise more efficiently and perform better in warm temperatures.

Respiratory Benefits

Part of the sympathetic nervous system response also relaxes smooth muscle in the bronchioles of the lungs, allowing for more efficient respiratory function. Patients with both asthma and chronic obstructive pulmonary disease generally report improved symptoms and ease of breathing while in the sauna, although longer-term studies have not generally shown an overall improvement in lung function with regular sauna use.

Musculoskeletal Benefits

During a sauna, joint synovial fluid becomes less viscous, allowing for improved joint mobility, and skeletal muscle is relaxed. These changes, along with the increased pain tolerance that one experiences, provide for a significant subjective decrease in musculoskeletal pain. Interestingly, for patients with rheumatoid arthritis and other autoimmune disorders, pain and inflammation have found to be increased on the day after taking a sauna—unless the sauna bath is followed by a cold immersion. For patients with arthritis that use cold-water bathing after sauna, there can be an overall improvement in symptoms.

Immune System

There are some studies that support the notion that regular sauna use stimulates the immune system. During a sauna session, white blood cells increase in the bloodstream, suggesting an elevation of the body's natural defense against illness. With routine sauna practice, at least one study has shown a decrease in the incidence of the common cold.

Psychological Benefits

One of the most common reactions to taking a sauna is that it simply seems to make people feel better. As it turns out, there are some measurable scientific reasons behind that.

Sauna exposure causes a significant release of Dopamine, a neurotransmitter, and Beta-Endorphin, a neuropeptide hormone. These substances cause a sense of euphoria,



Courtesy of EDEN ONE, Dublin (KLAFS)

Often missing from wellness seekers' sauna therapy is the cold immersion required to intensify the healthful results—a snow room or plunge pool (natural or man made) are ideal adjuncts to a sauna.

as well as improved mood, energy, sense of calm, and pain tolerance. (Endorphin is a combination of the words “ENDOgenous”, or occurring naturally in the body, and “moRPHINE”, a pain-relieving compound). The level of endorphins released during sauna bathing can be three times normal, similar to a middle distance training run. This “runners’ high” that occurs can be somewhat addictive and may affect regular sauna users in the same way it affects regular exercisers.

Sleep is also improved after a sauna, with some research showing longer stage 4 sleep, which provides a deeper, more restful sleep and healthier dream activity. Sleep affects so many other aspects of health, including mood, immune function, and ability to handle stress, that this alone would seem to suggest a significant health benefit from regular sauna use.

The psychosocial aspects of group activity such as sauna bathing may also be an important part of the health benefits of sauna. Social connection, sharing with friends and feeling a part of a community, as well as the personal nature of conversation that is fostered in the sauna, all play parts in the cultural validity of group sweating that has existed in so many cultures over time. In addition, for those cultures that promote nudity in the sauna, a sense of equality and openness exists that one does not normally experience in every day life.

Risks

While quite safe if done in moderation, sauna bathing can present health risks. Because the body uses sweat to help regulate core temperature during a sauna, dehydration can be a problem with excessive sauna use. Some athletes, such as wrestlers, have used the

sauna for rapid weight loss through loss of water through sweat, and this has occasionally led to heat stroke and sudden cardiac death. When combined with the misuse of diuretic pills, this practice can be especially dangerous.

Alcohol consumption creates many potential risks for the sauna user. Alcohol counteracts the anti-diuretic hormone that the body normally secretes during heat stress in order to help the kidneys retain fluid. In addition, alcohol causes the peripheral blood vessels to become even more dilated than usual in the sauna, which can lead to rapid fall in blood pressure and cause falls or fainting. Alcohol also excites cardiac muscle and reduces coronary artery flow, increasing the risk of both arrhythmia and myocardial infarction.

Cold-water immersion is a common practice following sessions in the sauna. This causes rapid constriction of the skin blood vessels, which causes blood pressure to increase (as opposed to in the sauna where it remains stable). There is also a significant stimulation of the sympathetic nervous system, with rapid increase in adrenaline, heart rate, and also endorphins. Hence, the sense of euphoria and well being that one experiences following cold immersion intensifies that from taking a sauna alone.

Data is mixed regarding the benefit of cold immersion for muscular tissue following exercise, but there are several studies that support improved blood flow and more rapid recovery of muscular damage and soreness with cold immersion. As mentioned above, those with inflammatory conditions like rheumatoid arthritis demonstrate benefit with cold water immersion following sauna bathing.

Of concern, however, is the fact that cold immersion can lead to cardiac arrhythmia and coronary artery spasm, making it potentially dangerous to those with heart disease. There are cold receptors in the face and scalp that respond to a rapid fall in temperature. This stimulates the “diving reflex”, which is a complex cardio respiratory reaction that causes apnea and a sense of shortness of breath, decreased cardiac output, and rapid decrease in pulse. Heart arrhythmias are common during this response, and can pose a danger to those prone to dangerous heart rhythms or at risk for heart attack.

As we can see, while people with heart disease can generally use the sauna safely, this is a population that should absolutely avoid alcohol before and during sauna bathing. In addition, these individuals should take extra caution when plunging in cold water to avoid exposing the face and head. A cool shower or slower cooling simply by sitting outside is generally considered safer practice for this group.

In conclusion, sauna bathing causes the body undergo many physiologic changes in attempt to protect itself against heat stress. Some of those adaptations can provide health benefit, most notably to resting blood pressure. There also evidence to suggest improved function in other aspects of cardiac, respiratory, musculoskeletal, and immune function. Regular sauna use increases the ability for athletes to train or perform in heat, and post exercise saunas may improve endurance. Many of the benefits of sauna bathing are psychological, including improved sleep, mood, and pain tolerance. Cold plunging following a sauna can accentuate some of these benefits, but caution is advised regarding immersion of the face and head. Alcohol use before and during the sauna is also ill advised, as is the practice of using the sauna for rapid weight loss. Otherwise, sauna bathing is considered very safe and regular use can benefit overall physical and mental health.

Heat storage ceramics provide mild, pro-active infrared C radiation to irradiate the whole body.



Courtesy of Sommerhuber

Benefits of Infrared Heat

Infrared saunas have grown in popularity in recent years due to their particular health benefits and the ability to heat a bather's body without warming the air around it.

Infrared radiation is heat that is on the longer range of the electromagnetic spectrum—and, because of this, it's considered more mild and comfortable and can penetrate the superficial layers of the skin, providing a sensation of deep warmth. The water molecules in our body are the first to react to infrared heat and, once activated, they dilate the blood vessels and set the entire metabolism in motion. The longer the wavelength, the more soothing and relaxing the experience is.

The longer wavelengths are absorbed by the upper layers of the skin (epidermis), where the autonomic nervous system is located. Our autonomic nervous system coordinates both voluntary and involuntary actions, transmitting signals to and from different parts of the body. Involuntary actions, like blood flow and the operation of internal organs, are controlled by the parasympathetic nervous system. Its tasks include regulating the body to its environment, like maintaining core body temperature of 37°C (98.6°F) by adapting its biological rhythms. The nerve endings in our skin respond to temperature stimuli and by irradiating the whole body, the nervous system is activated and metabolism is set in motion. Some of the benefits include:

- Increased metabolism
- Increased relaxation, reduced tension
- Replenished, rejuvenated skin
- Increased oxygen supply which, in turn, heats the body and burns fat
- Detoxification
- Stimulate blood flow
- Reduce blood pressure
- Decrease pain and inflammation

Heat storage ceramics (versus a separate infrared radiator) provides a mild, pro-active infrared experience that emits infrared C radiation (long-wave).



Courtesy of TechnoAlpin

Snow rooms offer a very appealing option for cold therapy. This snow room is serving a dual purpose: as a cool down area and simulating fitness training in cold temperatures.

Benefits of Hot/Cold Contrast Therapy

Hot/cold contrast therapy, or thermotherapy, involves alternating between hot and cold temperatures to treat various conditions, enhance recovery and illicit feelings of euphoria. Here are some of the noted potential benefits of hot/cold contrast therapy:

- **Improved circulation:** Alternating hot and cold causes the blood vessels to dilate and constrict, which may increase blood flow throughout the body. Increased circulation can help to deliver nutrients and oxygen to muscles and remove waste products.
- **Reduced inflammation and swelling:** Cold therapy can reduce inflammation and swelling, especially after an acute injury. Hot therapy may also promote the alleviation of chronic inflammation.
- **Pain relief:** Heat reduces muscle stiffness and soreness by increasing blood flow and making tissues more pliable, while cold therapy can numb the painful area and reduce the sensation of pain.
- **Faster recovery times:** Contrast therapy assists in recovering from intense workouts and can help reduce muscle soreness and fatigue, enabling a quicker return to training.
- **Improved immune response:** Evidence suggests hot/cold contrast therapy can stimulate the immune system, potentially increasing the body's ability to fight off illness.
- **Stress reduction and mood enhancement:** The hot portion of the therapy can promote relaxation and help to reduce stress. In contrast, cold therapy can lead to invigoration and increased mental alertness.
- **Enhanced detoxification:** By stimulating blood flow and lymphatic circulation, contrast therapy might help in promoting the elimination of toxins from the body.

It's important to note that while these benefits are reported, individuals may respond differently to hot/cold contrast therapy. It is also not suitable for everyone; people with certain medical conditions, such as heart disease or peripheral neuropathy, should consult a healthcare provider before trying contrast therapy. Additionally, care should be taken to avoid thermal injuries, such as burns or frostbite.

The use of aromatherapy to improve mood and well-being is long documented in many cultures. Today, aromatherapy is an important part of any spa and wellness offering.



Courtesy of Gharieni Group

Benefits of Aromatherapy

Humans have been using aromatherapy (defined by the National Association for Holistic Aromatherapy as the therapeutic application or medicinal use of aromatic substances for holistic healing) to improve mood and well-being since time began. Very little specifics are known about the history of aromatherapy, but Egyptians are credited with developing the earliest distillation process for extracting oils from certain plants which they then used to embalm the dead. It's the Chinese who are believed to have begun the practice of using infused aromatic oils as mood enhancers or to help with physical aches and pains. The Greeks also played a role; Greek mythology claims that the gods were gifted with the knowledge of perfume and fragrance. However, the term “aromatherapy” was originally coined by the French chemist Rene-Maurice Gattefosse in 1937 after discovering the healing and soothing effects of lavender oil on burns he suffered in a lab accident; and a French surgeon, Jean Valnet, adopted essential oils to help heal soldiers' wounds during World War II. Today, the intense effect fragrances have on our state of mind is well known and aromatherapy is common not only in spas around the globe but everywhere humans dwell.

Scents are so powerful because our olfactory receptors transmit nerve impulses about odors to the central nervous system. As the signals reach the brain, they affect our autonomic nervous system and can cause subtle changes in our bodies, including on our heart rate, blood pressure, breath, memory, stress, and even hormone balance. The olfactory pathway also connects to our limbic nervous system, which is responsible for processing emotions and instincts and includes the hippocampus, which is responsible for long-term memory—something that helps explain why the whiff of certain fragrances can bring up spontaneous images and memories deep in our subconscious.

Aromatherapy is very effective in hydrothermal areas and most commonly used as an inhalant—breathed in through the nose via steam or vapors—and, of course, essential oils can also be blended with carrier oils and/or lotions and applied topically.

Essential oils are attributed with mood enhancing properties and are commonly used to treat the following:

- **Agitation:** Chamomile (Roman), Lavender, Mandarin, Sandalwood
- **Anxiety/Fear:** Bergamot, Chamomile (Roman), Cedarwood, Frankincense, Jasmine, Lavender, Neroli, Patchouli, Rose, Sandalwood
- **Fatigue:** Basil, Bergamot, Clary Sage, Frankincense, Ginger, Grapefruit, Jasmine, Lemon, Patchouli, Peppermint, Rosemary, Sandalwood
- **Isolation:** Chamomile (Roman), Bergamot, Clary Sage, Frankincense, Rose
- **Memory Boosters:** Basil, Cypress, Lemon, Peppermint, Rosemary
- **Sadness/Grief:** Bergamot, Chamomile (Roman), Clary Sage, Frankincense, Grapefruit, Jasmine, Lavender, Lemon, Orange, Rose, Sandalwood, Ylang Ylang
- **Self Esteem:** Bergamot, Cypress, Grapefruit, Jasmine, Orange, Rosemary
- **Stress Relief:** Bergamot, Chamomile, Lavender, Lemon, Orange, Patchouli, Vanilla, Ylang Ylang

Common Essential Oil Attributes

Essential oils all have different uses and effects, below are the attributes of some of the more widely used scents:

- **Basil:** Used to sharpen concentration and alleviate some symptoms of depression.
- **Bergamot:** Used to treat stress, depression, anxiety, anorexia, and a number of skin infections like psoriasis and eczema. Can also stimulate the liver, digestive system and spleen.
- **Cedarwood:** A calming agent that alleviates stress and anxiety. It also plays a role in aiding respiratory problems as well as skin issues.
- **Chamomile:** A powerful calming agent, as well as antibiotic, antiseptic, antidepressant and overall mood lifter.
- **Eucalyptus:** Commonly used to treat respiratory issues, and also as an antiseptic, antispasmodic, decongestant, diuretic and stimulant. Its cooling properties help with muscle aches and pains and can also be used to fight migraines and fevers.
- **Jasmine:** This scent increases the beta waves in the brain that are linked to alertness, it's also thought to ease depression and to enhance libido.
- **Lavender:** Commonly used for stress-relief and to enhance relaxation and sleep. It is also said to relieve headache and migraine symptoms.
- **Lemon:** Can be used to help relieve the symptoms of stress and depression. It also helps with skin irritation, digestion and circulation problems.
- **Marjoram:** Aids in relieving anxiety and stress, also used to combat fatigue and depression and alleviate respiratory and circulatory issues.
- **Patchouli:** Said to promote skin cell growth, it also helps relieve anxiety, depression, fatigue, and reduce bloating.
- **Peppermint:** Cooling agent that enhances mood, sharpens focus, combats irritation and redness, alleviates symptoms of congestion, and aids in digestion.

- **Rose:** A multi-purpose scent that helps with depression, anxiety and digestion issues. It also helps with circulation, heart problems and respiratory conditions like asthma.
- **Rosemary:** Widely known as a stimulant, its antidepressant properties make it ideal for enhanced memory, focus and overall brain performance. It also acts as an analgesic, soothing aching, cramping muscles, headaches and migraines. As an antiseptic it helps with digestive and liver infections.
- **Sandalwood:** Most often used for its calming and aphrodisiac properties.
- **Tea tree:** A natural immune booster with antimicrobial, antiseptic, and disinfectant qualities that is commonly used in shampoos and skin care products to treat acne, burns, and bites.
- **Ylang-Ylang:** Calming scent that soothes headaches, nausea, skin conditions, and is thought to reduce high blood pressure and fight intestinal problems.

Essential oils have numerous benefits, but if used improperly the effects can be hazardous. For example, photosensitive oils like bergamot, grapefruit, lemon, lemongrass, lime, and sweet orange can act as a sun enhancer or burn the skin so should be avoided in hydrothermal areas.

Benefits of Floatation Therapy

Unlike other hydrothermal modalities discussed throughout this guide—which can be traced back centuries to ancient civilizations—the practice of floatation therapy is part of modern history, dating back to the 1950s when Drs. Jay Shurley and John Lilly at the National Institute of Mental Health became interested in understanding how the human brain would respond to an environment devoid of external sensory input. Since then, there have been a number of publications that have explored the potential therapeutic benefits of floating. The most consistent observation to date has been significant reductions in levels of subjective stress and increases in relaxation as measured from pre- to post-float. In addition, floating has also been reported to decrease blood pressure, heart rate, and cortisol levels.

In recent years, there's been a marked increase in interest of Floatation-REST (Reduced Environmental Stimulation Therapy) both for its benefits of alleviating chronic pain—the buoyancy of a float tank's dense salt water solution (created by the addition of Epsom salts) supports the muscular, skeletal and circulatory systems with zero pressure—and for the positive effects of the absence of external stimuli enabled the mind and body to give itself over to complete rest, relaxation and recovery. Given that we live in a world of constant sensory inputs, the benefits of spending time in isolation floating weightlessly has an obvious appeal.

Some of the most profound and interesting research on Floatation-REST was released in 2018 when Dr. Justin Feinstein of the Laureate Institute for Brain Research (LIBR) in Tulsa, Oklahoma, USA published a peer-reviewed study on the use of floatation for treating severe mental issues, including PTSD, panic disorder, depression, agoraphobia and other forms of anxiety. Because Dr. Feinstein recognized that patients that already suffered from anxiety could perhaps be made more anxious if asked to enter an enclosed pool or pod, his research is based on open round pools—marking the first time this type of floatation tank has been validated in a study.



Courtesy of Floataway

The buoyancy of a floatation tank and the absence of external stimuli helps the body and mind give itself over to complete rest, relaxation and recovery.

The results were impressive—after a single one-hour float, all 50 participants in the study reported a strong reduction in anxiety and stress-related disorders. Beyond the immediate reduction in anxiety, the float experience also induced a significant decrease in self-reported stress, muscle tension, pain, depression, along with a significant increase in serenity, relaxation, happiness, positive affect, overall well-being, energy levels and feeling refreshed.

Common benefits of floatation therapy include:

- **Stress/anxiety reduction:** Studies support the efficacy of floatation therapy in reducing stress and anxiety levels. Pain management: Evidence shows that floatation therapy can alleviate chronic pain, making it a potential treatment for conditions like migraines and fibromyalgia.
- **Cognitive enhancement:** Research indicates that float therapy can facilitate creativity and problem-solving skills by enabling theta brainwave states.
- **Improved sleep and concentration:** Indications are that the level of deep relaxation achieved during float sessions can help reset sleep patterns and assist with improving concentration.
- **Mood enhancement:** Floatation can lead to the release of endorphins, the body's natural "feel good" chemicals. Improved mental health: Studies suggest positive uses of floatation therapy for mental health conditions such as PTSD and depression.
- **Muscle relaxation and reduced joint pain:** The buoyant and supportive environment allows muscles to deeply relax, alleviating tension and stiffness and reducing the pressure on joints and muscles. In addition to an enjoyable experience, many users report reduced pain levels after a float session, especially those with chronic pain conditions such as arthritis, MS, and migraines.
- **Improved sleep and benefits to the immune system:** A large proportion of the population are deficient in magnesium which has a major impact on the immune system and sleep. Epsom salt contains magnesium and one of the most effective ways to absorb magnesium is through the skin.
- **Natural detoxification:** The improved circulation and reduction of stress levels can help with the body's natural detoxification process.

Further Resources

There is a wide array of evidence of the effectiveness of hydrothermal therapies to explore. To start your research, try these resources:

- **Contrast Water Therapy:** www.ncbi.nlm.nih.gov/pubmed/23626806
- **Heat Therapies (Saunas, Hot Tubs) Offer Some Similar Benefits as Exercise:** <https://journals.physiology.org/doi/full/10.1152/jappphysiol.00608.2020>
- **Hydrotherapy for Depression:** www.psychologytoday.com/blog/inner-source/201407/cold-splash-hydrotherapy-depression-and-anxiety
- **Hydrotherapy in Heart Health:** [www.internationaljournalofcardiology.com/article/S0167-5273\(14\)02069-5/abstract](http://www.internationaljournalofcardiology.com/article/S0167-5273(14)02069-5/abstract)
- **Hydrotherapy in Stroke Rehabilitation:** www.ncbi.nlm.nih.gov/pubmed/26130657
- **Reducing Pain in Fibromyalgia:** www.ncbi.nlm.nih.gov/pubmed/25000940
- **Regular Sauna-Going Tied to Wide Array of Health Benefits:** [https://www.mayoclinicproceedings.org/article/S0025-6196\(18\)30275-1/fulltext](https://www.mayoclinicproceedings.org/article/S0025-6196(18)30275-1/fulltext)
- **Enhanced Recovery After Exercise with Hydrotherapy:** www.ncbi.nlm.nih.gov/pubmed/18058595
- **Hydrotherapy Reduces Pain in MS Patients:** www.ncbi.nlm.nih.gov/pubmed/21785645
- **Hydro-rehab in Knee and Hip Arthritis:** <http://onlinelibrary.wiley.com/doi/10.1002/14651858.CD005523.pub3/full>
- **Floation-REST for Treating Depression and Anxiety:** <http://journals.plos.org/plosone/article?id=10.1371/journal.pone.0190292#sec017>
- **Altered Consciousness in Sensory Deprivation:** www.nova.edu/ssss/QR/QR13-4/kjellgren.pdf
- **Floating and Muscle Tension, Stress:** <http://bmccomplementalmed.biomedcentral.com/articles/10.1186/1472-6882-14-417>
- **Aromatherapy Studies:** www.wellnessevidence.com/wellnessevidence/aromatherapy/spotlight
- **Heat Therapies (Saunas, Hot Tubs) Offer Some Similar Benefits as Exercise:** <https://journals.physiology.org/doi/full/10.1152/jappphysiol.00608.2020>
- **Regular Sauna-Going Tied to Wide Array of Health Benefits:** [https://www.mayoclinicproceedings.org/article/S0025-6196\(18\)30275-1/fulltext](https://www.mayoclinicproceedings.org/article/S0025-6196(18)30275-1/fulltext)
- **Frequent Sauna Use Tied to Less Stroke Risk:** <https://www.neurology.org/doi/10.1212/WNL.0000000000005606>
- **Study Suggests Regular Sauna-Going Lowers Risk for Hypertension:** <https://academic.oup.com/ajh/article/30/11/1120/3867393>
- **Time in Saunas Associated with Reduced Risk of Alzheimer's & Dementia:** <https://academic.oup.com/ageing/article/46/2/245/2654230>



Chapter 3

Project Planning: Architecture & Design

This chapter gives readers a broad overview of what to consider during the planning and building stages of a residential or commercial spa. It is designed to help the reader understand what goes into the build and how to prepare for it, including assembling a project team. It outlines some of the major oversights and how to avoid them.

Perhaps surprisingly, one of the most significant stumbling blocks in the planning of a hydrothermal spa area—whether it’s commercial or residential—is a misunderstanding of basic terminology and functionality. There can be a lot of confusion around what each of the thermal cabins does (i.e., are they dry or wet? hot, humid or cold?) or how a pool functions. Because terminology can differ from country to country, the confusion is often escalated. For example, what’s the difference between a hamam and a steam room? a sauna or a banya? or a steam shower and an experience shower? If the whole team does not “speak” the same language, it becomes impossible to deliver to a client’s expectations.

This guide will help minimize these issues by providing clear definitions of the hydrothermal features that are typically included in a modern build. The reader will find detailed descriptions of thermal rooms and other specialist treatment rooms (see Chapters 4 and 5) and hydrotherapy pools (see Chapter 6), as well as a glossary of key hydrothermal terms. However, it should be noted that this is only a starting-off point, and, regardless of the size of a build, it is always recommended that a hydrothermal specialist be appointed at the outset of the project. Without a hydrothermal specialist on the team, there will always be a risk of overlooking some very basic requirements that could ultimately end up costing both time and money.



During the initial client briefing, the entire scope of the project—including reception area requirements—will be discussed.

Assembling a Project Team

A commercial build of this type requires a hydrothermal specialist or consultant, but it is also crucial to engage an architect and interior designer, preferably one with spa experience. In addition, an operational spa consultant should be a key part of the team. They will help define the project and create the business plan; plot the flow of guests through the spa; assist in choosing the products and services required; and coordinate staff recruitment/training, etc.

Given that “hydrothermal” design and building is the topic of this guide, throughout this chapter, we will pay particularly close attention to the crucial role that a hydrothermal consultant plays in delivering a successful project. Hydrothermal consultants are able to provide authoritative expertise on every aspect of your hydrothermal build, including:

- Space requirements for thermal rooms/pools and behind-the-scene equipment
- Deep understanding of people flow of both guests (bathing journey) and staff
- Materials and construction techniques required to handle water, humidity, heat
- Minimizing noise emission and potential water egress
- Building to local codes and ADA standards
- Sustainable, environmentally-conscious building practices

A proactive client will listen to his/her team’s advice, but will also be prepared to question it. It’s highly recommended that anyone embarking on such a project makes numerous spa visits, including to spas that members of the team have designed, operated, built or consulted on. If possible, speak to other spa owners/operators to identify critical success factors and the things they may have done differently. A hydrothermal spa based on a single team member’s personal tastes or operating experience is usually a recipe for an unsatisfactory project. Instead, a spa that meets an owner/operator’s vision, while incorporating industry best practices and unique customer selling points is the ultimate desired outcome.

In short, hydrothermal spa design is a complex process that requires a specialist designer with expertise in both design and engineering and who has a unique understanding and appreciation for integrating both into a single space. Typically, lead designers on large commercial projects will employ a specialist sub-consultant to carry out the spa design.

Hydrothermal Specialist Team

Don't underestimate the complexity of the building services associated with a wet spa. Even if an architect and interior designer have been involved in this type of build before, it doesn't necessarily mean they have the detailed expertise required to properly execute these critical areas.

A successful build is based on collaboration between the design/construction team and a specialist wet area team that will bring detailed knowledge of hydrothermal spa requirements. Regardless of the size of the project, wet spa equipment supplier(s) and consultants should be selected at the outset of the project, so their specific requirements are communicated to the design/ construction team in order to create a successful project through the conventional design phases as outlined above.

It's important to identify early in the process who is in charge of the coordination of the various subcontractors. Ideally, this is a project manager who is able to oversee the other contractors and has an understanding of wet area specifications, such as the type of insulation and waterproofing that are necessary; as well as providing insight into the pipe work, sprinkler systems, concrete works, plant rooms, plinths, balance tanks, etc. These will all be installed by various contractors, but the wet area specialist should help get the basics right—such as the floor slab, its water proofing and slope—correct the first time around.

For a large commercial build your hydrothermal team will look like this:

- **M&E or MEP consultant:** all mechanical and electrical interfaces, including ventilation, plant room, drainage, etc.
- **Structural engineer:** works on the details of all major building works, including pool structures and prefabricated cabin rooms, etc. (can be part of the architectural team)
- **Hydrothermal equipment provider:** can work with a hydrothermal specialist or independently to advise not only on equipment required but also on the layout of cabins, pools and people flow and will ensure plant/mechanical rooms are properly situated.

Client Provided Architectural Plans Before Involving a Hydrothermal Specialist

Initial architectural plans typically require specialist knowledge when it comes to space planning and other key details for hydrothermal features.

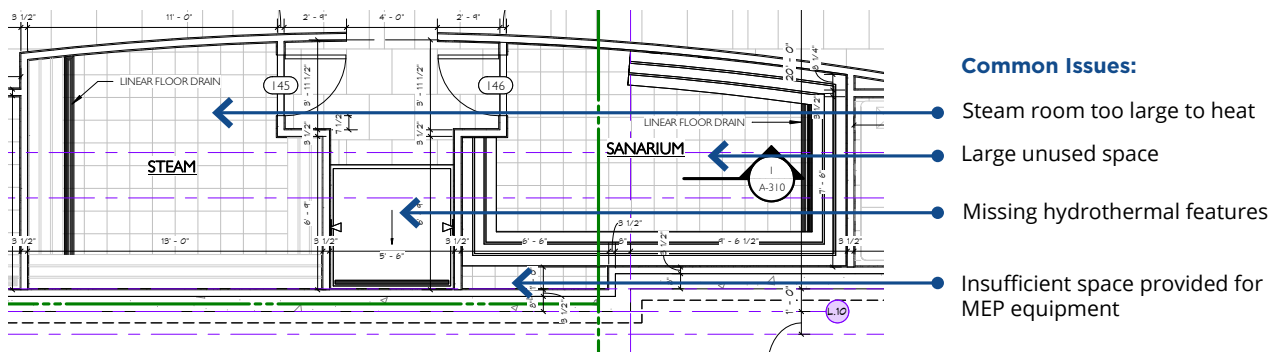

Commercial Spa Design Stages

The design stages of a project are typically as follows:

0. Definition	1. Preparation & Client Briefing	2. Concept Design
3. Schematic Design	4. Detailed Design	5. Tender & Construction Documentation
6. Construction	7. Handover & Close Out	8. Operational

This chapter covers the design stages 1 through 6 in detail. Your hydrothermal spa specialist will also have a role in the handover and, together with the operational spa consultant, will ensure the area is fully operational at opening.

Stage 1: Preparation & Client Briefing

After the project has been defined and the vision for the hydrothermal area has been established by both the spa owner/operator and the operational spa consultant, it's time to assemble the entire project team. In this stage, the project team meets with the client to ascertain requirements, unique selling points (USPs) and overall vision. The briefing should cover these basic points so the team understands the basics of the build:

- Architectural space allocated to spa area
- Cultural/regional requirements
- USP's: Signature spaces/treatments
- Reception requirements
- Retail space needs
- Spa food & beverage (F&B) offering
- Number of treatment rooms
- Relaxation space
- Changing rooms
- Wet areas (pools/thermal cabins)
- Back of House (BoH) requirement: offices; prep areas; pantry/linen storage

Stage 2: Concept Design

Step 1: Adjacency Plans (also known as ‘bubble diagrams’), including:

- Architectural space (access points, lifts, and views)
- Guest flow/journey (considering male, female and disabled guest)
- Staff flow (discreet staff movements for guest privacy)

Step 2: Concept Design

This is the first time that the client will be able to visualize their spa design, including:

- Reception layout including consultation space (privacy)
- Retail space
- Spa F&B
- Changing rooms: locker/WC's/vanity areas
- Wet area design: types of pools & thermal cabins (avoiding cross over from wet to dry areas)

Consulting with Hydrothermal Specialist During Concept Design Prevents:

- Underestimating/ignoring space required for plant room and mechanical equipment
- Lack of attention to people flow—both of guests and staff
- Not accounting for variances in cultures and the types of treatments and facilities guests will want and use (i.e., know your target audience)

Key Benefits:

Balance is important. When the concept design is done right, your build will achieve the correct balance between water (pools), thermal experiences (saunas, steam rooms, etc.) and other guest amenities to ensure the best guest experience.

Typical Adjacency Plans

- Treatment rooms and types (single/double/VIP)
- Relaxation space: loungers/ beds
- Plant room requirements
- Back of House (BoH)
 - Office requirements (spa director, administration, reservations)
 - Prep areas/dispensary
 - Pantry
 - Clean & dirty linen distribution
 - Storage space
 - Cleaners' storage
 - Plant/technical room

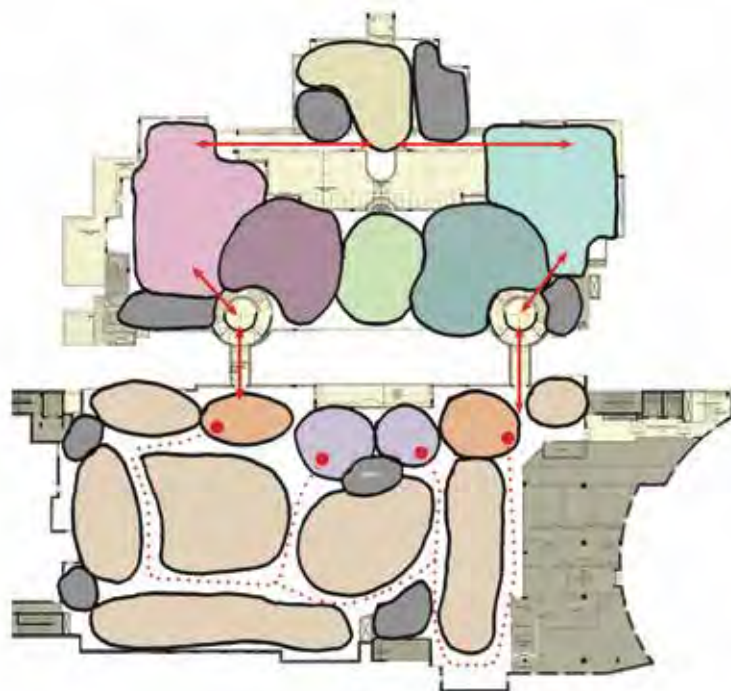

Bubble diagrams are color-coded to indicate how each space in the spa area will work and also help illustrate people flow, both of guests and staff.

During this phase, the hydrothermal specialist will also consider areas where the client can maximize revenues, including:

- Flexibility to swing or change male/female occupancy depending on demand
- Special chargeable treatments (e.g. Rasul mud bath, hamam, floatation tank, cryotherapy, etc.)

Two major areas the hydrothermal specialist will bring to the attention of the client at this stage of the design development is:

- Ensuring integration with general building MEP requirements (best achieved if project is utilizing the latest Building Information Modeling (BIM) design software)
- Plant room size and location
 - Optimize plant room size but ensure sufficient space to allow for future plant maintenance
 - Plant/Mechanical rooms should never be located near quiet relaxation areas.
 - Plant/Mechanical rooms should be located near the pools (beneath the water level) and thermal cabins
 - Electrical loading and MEP requirements: Power/Water/Drainage/Ventilation
 - Sustainability: LEED/BREEAM requirements may have to be considered
 - Technical equipment selections

Step 3 - Mood Boards & Samples

There should be careful consideration of finishes and materials in wet areas.

- Avoid soft stone materials that absorb water
- Consider any potential slip hazards
- Potential oil stains should be taken into consideration when choosing fabrics

Concept Plan Example

A concept plan like this offers clients the first opportunity to fully visualize what their spa will look like within the space.

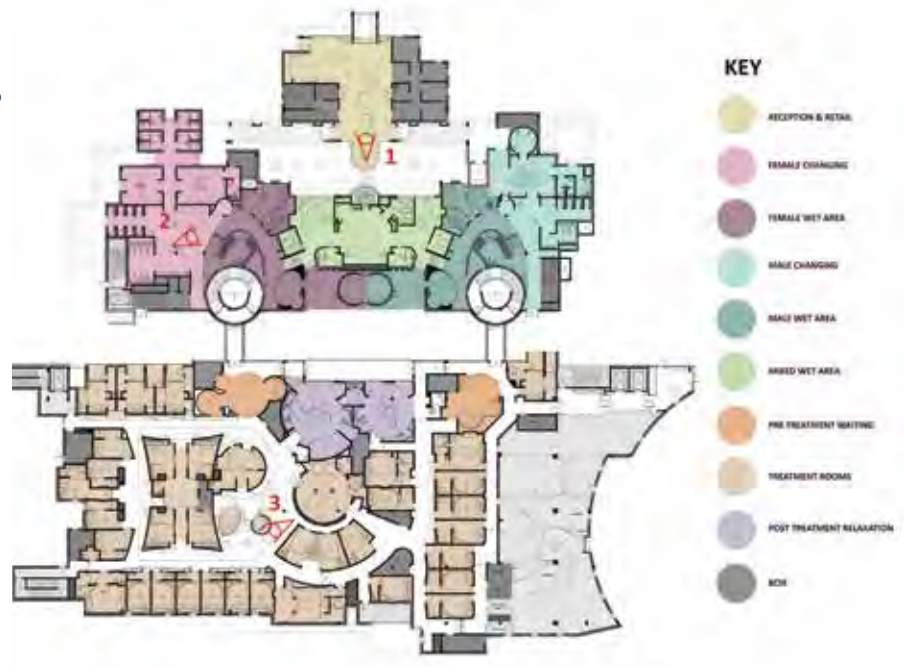

Schematic Design Example of a Steam Room

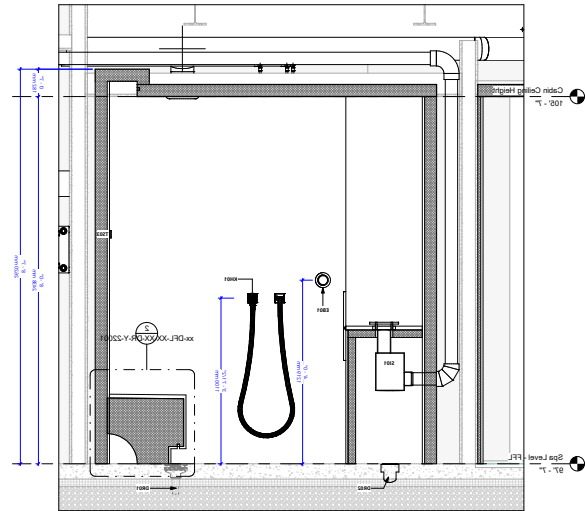
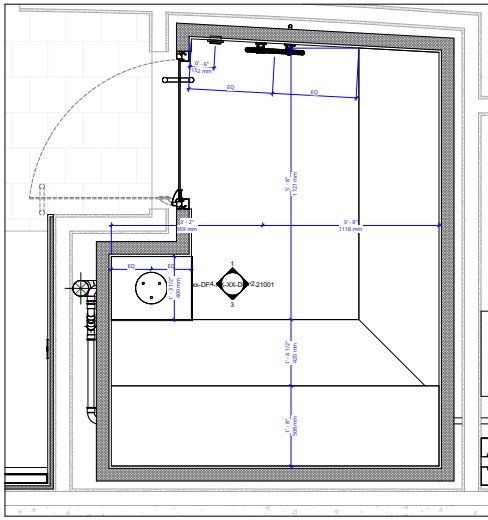

Stage 3: Schematic Design

At this point the project drawings will ‘prove’ the concept design and ensure everything fits into the building. Also at this stage the hydrothermal/spa design specialist should provide a schedule of costs with budget/target prices to assist the client to finalize his overall budget for the project.

Computer generated images (3-D renderings) will frequently be created at this stage to allow the client to fully visualize the finished spa.

The Process

- Appraise layouts indicating spatial and building code requirements, ADA compliance, methods and materials of thermal room and vessel pool construction
- Define performance specifications and equipment criteria
- Prepare Preliminary MEP information and equipment requirements
- Define space/location requirements for mechanical rooms
- Prepare preliminary budget estimates for construction
- Review suitability of finishes selected by design team

Consulting with Hydrothermal Specialist During Schematic Design Phase Prevents:

- Delays and re-fits (i.e., additional costs) are often caused when a wet area specialist is not involved schematic design.
- Failing to follow proper building, drainage, ventilation, and electrical standards
- Lack of focus on health, safety and hygiene in every aspect of the design
- Building with substandard materials that can't handle excessive heat and moisture

Key Benefits:

A hydrothermal specialist will be able to give you a clear vision of not only how spa features will look, but how each aspect will be built and function within the whole of the space.

Detailed Design Example of a Sauna

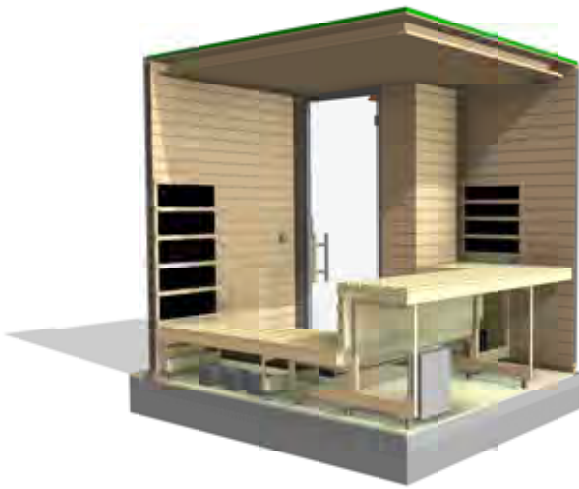

Door Detail



IR Panel Detail



Stage 4: Detailed Design

Detailed design starts with refining the schematic design and then providing the client with a complete set of drawings, room data sheets and schedules for doors, ironmongery, sanitary ware, feature lighting, finishes and furniture fittings and equipment. Completion of this is frequently referred to as “100% DD.”

In this phase, MEP routes are planned out to coordinate with other connection points at feature locations and incorporated into the documentation with their associated specifications. Detailed AutoCad and Revit drawings, including the often overlooked mechanical spaces, should also be provided.

The Process

- Prepare detailed floor plans and sectional elevations
- Finalize equipment schedules and MEP requirements
- Detail all MEP points of connection at thermal feature and mechanical room locations
- Specify interconnecting MEP service requirements for wet area features to be engineered and provided by others
- Add finishes specifications from others to the drawings

Consulting with a Hydrothermal Specialist During the Detailed Design Phase Prevents:

- Overlooking crucial MEP requirements this omission often means going back to the drawing board partway through a build, with time delays and extra costs
- Attempting to cut costs by not hiring specialists, such as MEP consultant or structural engineers; invariably this will cost more money in the long run
- Not specifying properly tested and certified waterproof construction materials

Key Benefits:

Provides a complete set of drawings and schedules for doors, ironmongery, sanitary ware, lighting, finishes, furniture and equipment.



Common Mistakes

- Delays and re-fits—i.e., additional costs—are usually caused when a wet area specialist is not involved during the preliminary design stages
- Underestimating/ignoring space required for plant room and mechanical equipment
- Lack of attention to people flow—both of guests and staff
- Not accounting for variances in cultures and the types of treatments and facilities guests will want and use (i.e., know your target audience)
- Noise is the enemy of a relaxing spa experience; whether it's a hydrotherapy pool or a plant room operating a steam room— put them where they can't be heard
- Lack of back of house areas
- Building with substandard materials that can't handle extensive heat and moisture
- Failing to follow proper drainage and ventilation standards
- Lack of awareness of health, safety and hygiene in every aspect of the design
- Attempting to cut costs by not hiring dedicated specialists, such as MEP consultant or structural engineers; invariably this will cost more money in the long run
- Not specifying properly tested and certified waterproof construction materials
- Not planning for the space required for the plant room
- Inefficient crossover of wet and dry areas
- Failure to maximize operator revenue

Detailed Design Example of a Mechanical Room

Detailed plant and technical equipment requirements are put in place now that the cabin requirements have been finalized. This enables connection points to be confirmed and the MEP routes established and also ensures there are no clashes between various trades when the project reaches the build stage.

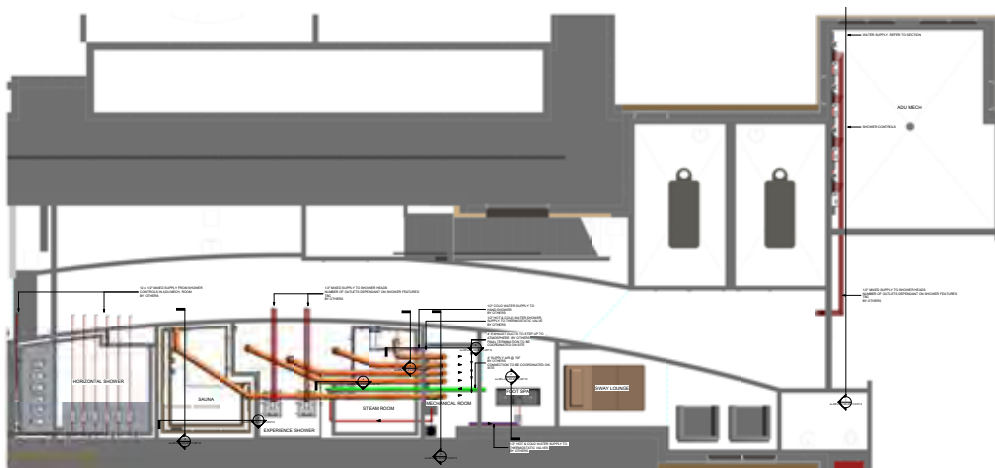



Courtesy of Barr + Wray Ltd.

Renders of all spa areas helps a client visualize the final spa design.

Stage 5: Tender & Construction Documentation

Once the client has approved the detail design then a full package of drawings, specifications and schedules is prepared with status “Issued for Construction” (IFC).

Additional services can also be provided by the hydrothermal/spa design specialist, including:

- Responding to tender queries from specialist spa fit out contractors
- Reviewing tenders from specialist spa fit-out contractors
- Participation in tender clarification meetings
- Prepare tender evaluation report and recommendations

Stage 6: Construction Supervision

Visit site on a regular basis to ensure that the spa installation contractor complies with the design specification and witness final testing and commissioning of all equipment, particularly in the wet areas.

Consulting with a Hydrothermal Specialist During the Construction Document Phase Prevents:

- MEP clashes when getting to site, e.g., avoiding issues such as wrongly positioned piping/ducting preventing the spa features from being installed
- Any equipment to be missed from the final specifications, which would result in significant delays on site
- Equipment not fitting due to lack of construction details/inaccurate information/attention to detail — all of which cause increased construction costs and delays

Space and People in Commercial Spas

The most crucial considerations in a new build are space requirements and people flow. A common error is underestimating the space required for the plant room and mechanical equipment. For example, a simple hydrotherapy pool may not look too big, but it requires almost as much space again for the associated plant and equipment. On the other hand, a Finnish sauna needs next to nothing in terms of additional space, unless it features an automatic essence dosing system, which requires its own plant cupboard.

Consideration for people flow (both for guests and staff) is also critical. Staff should have a completely different flow from guests so they can perform behind-the-scenes functions without being seen, like setting up treatments, gathering used linens and cleaning. Generally, the way people interact in hydrothermal areas differs greatly from the way they would interact in other public spaces. It's important to be aware of the need for extra personal space (see sidebar).

Additionally, the intense heat of the thermal treatments means that space must be allocated for cooling off (through showers and plunge pools) and relaxing between treatments. As an example, 10 minutes in a sauna requires 20 minutes to 30 minutes cooling time (of course, in practice, people will listen to their bodies and these times will vary significantly). Space should be allocated accordingly—if, for example, the thermal cabins in a spa seat 15 people, then the relaxation/ cooling areas need to accommodate at least the same number, if not more, people. The customer journey through the spa should also be logical and simple to follow.

Sample Spa Flow

When designing a hydrothermal spa area, the flow of both guest and staff must be well thought out. The above sample is suitable for virtually any culture/region; however, it's becoming more common to have mixed gender relaxation and spa areas.

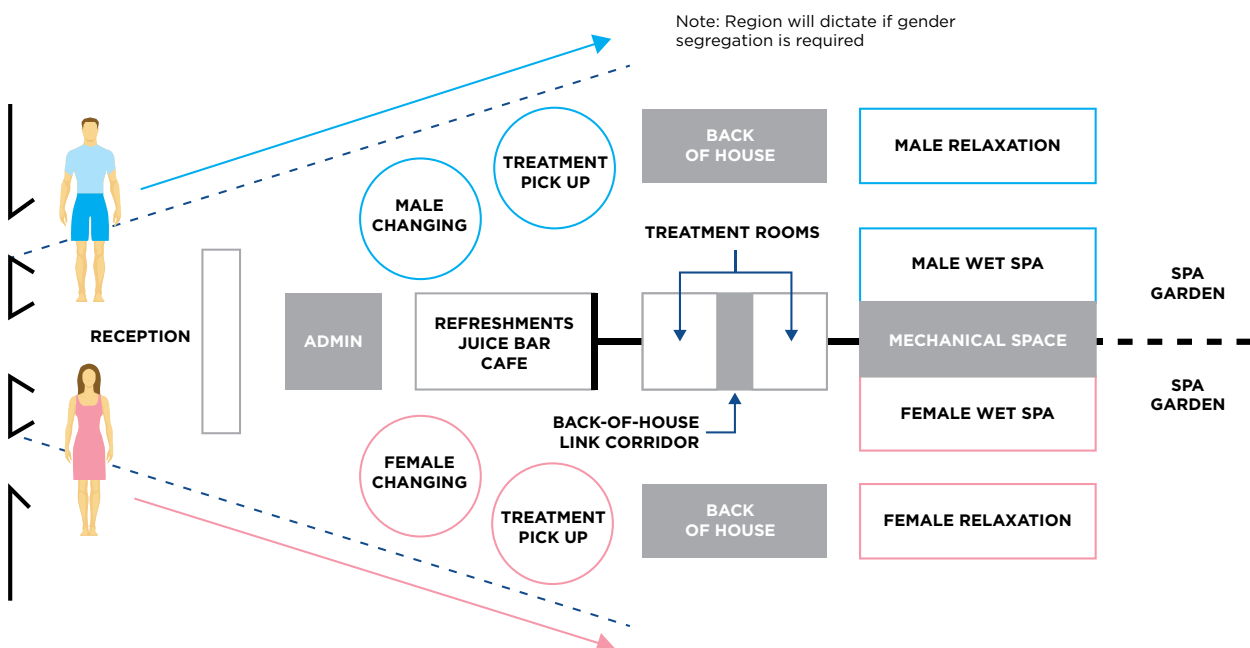

Human Interaction

When conceiving these areas, it is essential designers understand people fundamentally interact differently when they have few or no clothes on—personal space, in particular, becomes of the utmost importance. The way we interact in a bathing suit or completely naked is very different from how we generally interact in public spaces. Take, for example, public transport—here people often touch strangers, sitting thigh-to-thigh or standing shoulder-to-shoulder on a subway or a bus. By contrast, sitting and touching bare thigh to bare thigh in a sauna or steam room would be unacceptable for most. It seems obvious, but not accounting for an increased need for personal space is one of the biggest mistakes made in a hydrothermal construction project.

In practice this means creating wider hallways to avoid any “pinch-points,” where people must squeeze past one another; designing benches and seats to allow for adequate space between bodies (600 mm or 24” is recommended); and, where possible, providing individual seating so that bathers don’t have to consider invading another’s personal space on a communal bench.

If you’re designing a co-ed (mixed male/female) area, there are other considerations. For example, a standard practice when designing steam rooms and saunas is to include a clear view into the cabin so bathers can see exactly what is happening inside, including gauging the number of current occupants. A woman bathing on her own, for example, may not feel comfortable entering a busy sauna if there are only men inside. She may prefer to wait until some of the group exits or until other women enter the cabin.

Surfaces and Flooring

The surface finishes in all areas of the hydrothermal spa should be chosen based on how well they will accommodate users. For example, instead of traditional mosaic tile, consider larger slabs of stone or tiling to avoid grout lines every few inches—and to minimize the effects of wear and tear caused by the water’s properties. Also, avoid soft, porous stone, such as marble, in steam and wet rooms, as it, too, is prone to degeneration. It’s also important to not use very dark tiles so that cleaning staff can easily recognize areas that need cleaning.

The floor finish should be chosen to minimize the potential for slippage. Getting the floor finish and correct sloping angle is crucial for proper drainage, and to avoid accidents in wet areas. In places where a lot of water accumulates, such as those close to pool exits and steam rooms, proper drains and slopes need to be implemented in the screed below. Because the drainage in spas is very different to any other part of the building, it needs to be addressed in consultation with the wet-spa-area specialist.

Entries and Exits

Being able to easily enter and exit cabins is paramount. For example, in the event of a bather feeling unwell, he/she should be able to leave the cabin unhindered. This means doors must always open outwards and be free of any mechanical latching devices.

Disabled Access

Access for people with disabilities has become increasingly important in all builds, and the hydrothermal spa area is no exception. Providing this access is not only a law in some countries, but it's also a sign of inclusiveness and enables the facility to market to a broader number of people. And, the benefits of hydrothermal treatments to disabled persons, particularly with motor or physical disabilities, make providing access even more important.

In broad terms, disabled access means incorporating the following basics:

- Entry ramps
- Correct door widths
- Correct clearances on the pull and push side of doors
- Low-level emergency button inside the room for assisted exit
- Low-level bell at entrance to request assisted entry
- A disabled bathroom
- Accessible changing and locker rooms, shower areas
- Treatment rooms on the ground floor and/or lifts to upper floors
- Wheelchair access to treatment rooms (corridors, doors, turning radiuses)
- Hydraulic treatment tables

Laws related to disability are enshrined in statutes, such as the Disability Discrimination Act in the UK and the Americans with Disabilities Act in the U.S. These (and others) prohibit discrimination against people with disabilities, which can be visible, hidden, permanent or temporary. (More information can be found in Chapter 9.)

ADA Design Rules for Hydrothermal Rooms

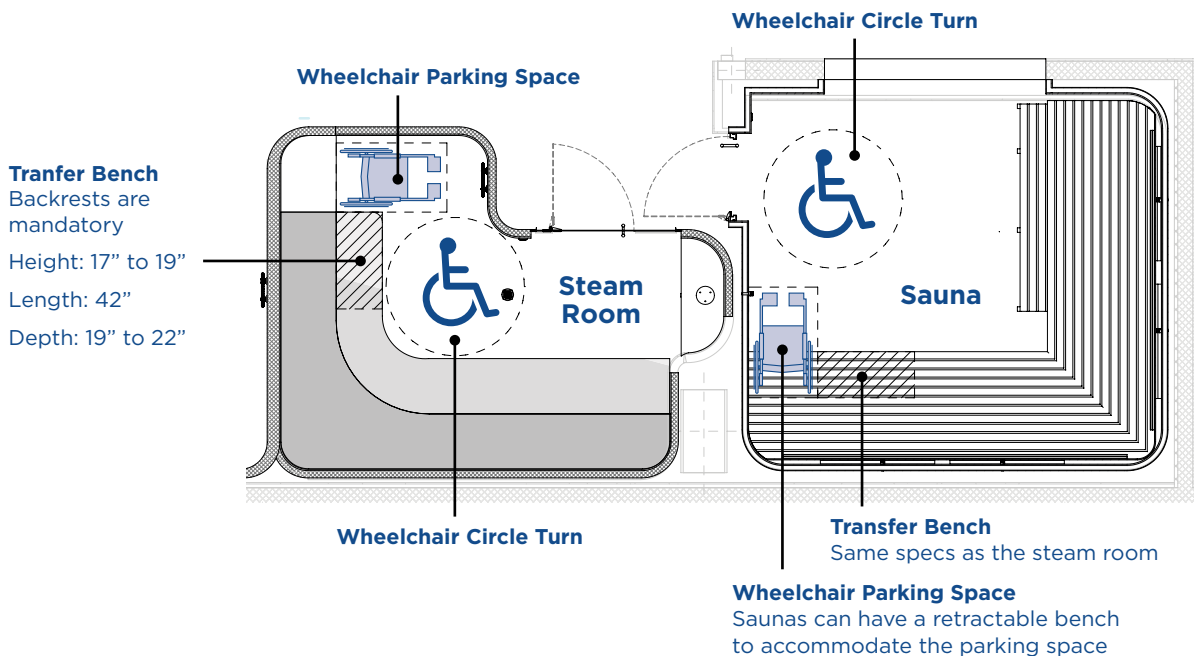



A hydrothermal team will ensure that all wet areas in a spa are well planned out and installed correctly.

Key Considerations

- Seek professional advice early—these are specialized areas; wet area specialists are required
- Be clear on budget—a wet area is not a place to cut corners; understanding this at the outset will minimize frustrations
- Know your audience—preferences around the world vary greatly so make sure hydrothermal features are targeted to your audience
- Balance is important—achieve the correct balance between water (pools) and thermal experiences (steam rooms, saunas, etc.)
- Don't underestimate space requirements—wet spa areas often require twice the space to accommodate behind-the-scenes equipment and maintenance
- Bathers and staff require different flows—understand who will be using and working in the various spaces and plan accordingly
- Don't forget the plant room and equipment—the detailed plant and technical equipment requirements (plant rooms, etc.) are frequently undocumented in early planning stages; this omission often means going back to the drawing board partway through a build—with consequent time delays and extra costs
- Noise is the enemy—customer relaxation will be non-existent and the ambience of the spa will be severely compromised if noise emissions aren't kept to a minimum (for example, a relaxation space should not be adjacent to a vitality pool, which can be quite noisy and often generates conversation)
- Water egress is also the enemy—a lack of detailed planning in the materials used, construction techniques and drainage can result in water leakage/damage throughout the facility, which can lead to health issues from mold and bacteria growth such as legionella

Return on Investment (ROI) for Hydrothermal Projects

When designed as a major feature of a spa or wellness center, wet areas can be significant profit centers. To help readers understand the numbers behind a typical hydrothermal project and to illustrate revenue potential, we have laid out relevant numbers. The financial example on the adjoining page is in \$USD and based on 2024 values. The prices are for a 4-star resort property and a large urban bathhouse and are indicative of costs/revenue builds in North America, the Caribbean and much of Europe and the Middle East. (Excludes any additional costs from specialty finishes.)

Unlike wet areas traditionally installed as locker-room amenities and provided free of charge (delivering minimal ROI), dedicated hydrothermal areas can generate significant profits—and increase guests' satisfaction and enjoyment with their stay—in a relatively fast timetable.

Advantages of Dedicated Hydrothermal Spa and Wellness Area

- Additional revenue opportunity
- At check-in, staff can easily upsell at a special “buy now” discount
- Entry fee will likely be lowest lowest-priced item on the spa menu
- Low-cost DIY experience is a great way to appeal to new spa goers
- Entry fee can be inflated to enable generous discounts to longer-staying guests or as a negotiating item when closing corporate or convention business
- Alternatively, surge pricing models can be adopted or off-peak rates, with further price points to cover exceptionally busy peak times or weekends
- Comping hydrothermal area entry for VIPs incurs minimal out-of-pocket expense, leaving treatment rooms and therapists available for paying guests

Hydrothermal Features: Resort Spa Example

- Male and female sauna and steam room, with unisex/coed features as below
- Sauna, steam room, laconium, snow room, foot spa, rain walk, hydrotherapy pool, cold plunge pool and wet lounge area for resting between periods in thermal areas
- $46 \text{ m}^2/500 \text{ ft}^2$ per gender plus $370 \text{ m}^2/4,000 \text{ ft}^2 = 460 \text{ m}^2/5,000 \text{ ft}^2$ total area including all circulation space

Hydrothermal Features: Urban Bathhouse Example

- Bathhouses generally have large bathing and social areas, often including F&B; instead of single-sex locker rooms, the example calls for mixed-gendered “changing villages” with private cubicles
- Includes multiple thermal rooms with different climates, lighting, and infusions (For example, a large, social sauna and a smaller, more meditative sauna)
- Must include cold facilities, like a plunge pool or ice room; as well as relaxation spaces
- $280 \text{ m}^2/3,000 \text{ ft}^2$ bathing areas plus $190 \text{ m}^2/2,000 \text{ ft}^2 = 460 \text{ m}^2/5,000 \text{ ft}^2$ total area including all circulation space

Return on Investment (ROI): Model Hydrothermal Project and Model Bathhouse Project

	Model Hydrothermal Project	Model Bathhouse Project
Estimated Building Costs		
Complete Installation	5,000 ft ² x \$900/ft ² = \$4,500,000	3,000 ft ² x \$450/ft ² = \$1,350,000
Wall, Floor & Ceiling Finishes	18,500 ft ² x \$50/ft ² = \$1,000,000	11,000 ft ² x \$20/ft ² = \$220,000
Grand Total	\$5,500,000	\$1,570,000
Estimated Spa Revenue		
Attendance Per Day	40 guests, 3 times a day = 120 guests (This size spa can easily support 60 guests at any one time, but let's assume we have just 40 guests every 4 hours during a 12-hour day.)	25 guests/per hour, 12 hours a day = 300 guests (Due to the local nature of the business and regular/repeat users, the traffic through the business would be higher, but guests would stay for shorter periods.)
Revenue Per Person	\$45 (The average charge is \$65, but we're using a reduced rate.)	\$30
Total Daily Revenue	120 guests x \$45 cost/person = \$5,400/day	300 guests x \$30 cost/person = \$9,000/day
Estimated Operational Costs		
Staffing Costs and Operating Overheads	30% of spa's total income (Staffing levels of hydrothermal areas are very low—no expensive therapists or downtime. Just a manager, meet and greet staff, spa attendants keeping space clean.)	20% of spa's total income
Estimated ROI		
Total Investment Recouped	36 months (Given the average life of a hydrothermal spa is at least 15 years, there is a significant return on the original investment by charging a market average entrance fee of \$90, but the illustration works well at even half that number.)	Approximately 32 weeks

Editor's note: These are simplistic illustrations to show basic figures and ideas on development costs. They are not designed to be a business plan and all those considering investing should work with an experienced Operational Spa Consultant to develop a robust and detailed business plan. No allowances have been made for interest on borrowings, property acquisition costs, permitting expenses and architectural design team costs, all of which should be accounted for in a detailed business plan.

For simplicity, square footage has been used in the example. Locker rooms are excluded as they rarely are required in destination resorts as guests arrive in robes. This also excludes general building services—all of which would be necessary. Costs include all technology and feature-specific building services and equipment, such as HVAC, specialist lighting within each experience, and all electrical and plumbing supplies required for mechanical/plant rooms.

International Codes and Standards

Regardless of the country a project is based in, there are internationally accepted codes and standards that hydrothermal specialists follow (be sure that your architect or builder is aware of them). In addition, you should consult relevant local codes and guidelines before proceeding with a build. Below is a list of commonly used codes and standards used in professional hydrothermal builds.

General Building Codes/Standards

- **Americans with Disabilities Act (ADA):** The disability code adopted by most builders/architects internationally; www.ada.gov
- **German DIN 18040-1:** German barrier-free building standards for disabled access; www.en.lehnen.de
- **International Building Codes:** Developed by the International Code Council, a U.S. organization that is dedicated to developing model codes and standards used in the design, build and compliance process to construct safe, sustainable, affordable and resilient structures. These codes are adopted globally; visit www.iccsafe.org
- **RIBA Plan of Work:** The Royal Institute of British Architects champions better buildings, communities and the environment through architecture; provides standards, training and support for architects; www.architecture.com

Sauna and Steam Room

- **German Sauna Standards:** Created by the RAL standards authority; www.ral-guetezeichen.de
- **ÖNORM M6219:** Austrian standard for planning and operation of steam rooms; www.bdb.at

Swimming Pools and Surrounding Area

- **BS EN 13451-1:2011, Swimming Pool Safety Requirements:** UK standards for general safety and testing of swimming pools and pool equipment; available at shop.bsigroup.com
- **German DIN 19643-4:** German standards for swimming pool water and bath water hygiene; available in English at www.beuth.de
- **German DIN 51097:** German standards for slip resistance; www.beuth.de
- **Pool Water Treatment Advisory Group:** A UK organization dedicated to raising standards in swimming pool water treatment; www.pwttag.org
- **International Swimming Pool and Spa Code (ISPSC):** Developed with the Association of Pool & Spa Professionals (APSP), the ISPSC establishes minimum regulations for public and residential pools, spas and hot tubs; <https://www.iccsafe.org>
- **Trade Rules of the Swedish Ceramic Tile Council for Wet Areas:** Best practices adopted by most hydrothermal experts for installing ceramic tile; www.bkr.se



Chapter 4

Communal Thermal Bathing Areas



Courtesy of Cedar Spa at Four Winds Casino (DFL)

The rising global trend of communal thermal bathing reflects a reinvigorated appreciation for traditional practices that utilize the therapeutic properties of water and heat. This chapter explores popular communal bathing experiences and takes a deep dive into thermal bathing features, including function and design.

Cultures worldwide have long recognized the health benefits of thermotherapy and hydrotherapy, particularly in the form of hot and cold contrast treatments. The COVID pandemic not only heightened the appeal of social wellness but it also shifted people's wellness priorities. As a result, more communal thermal bathing facilities are being developed to answer these needs. Here we look at some of these new business models and explores the common features found in a modern bathhouse or spa.

Types of Communal Bathing

In the past, the majority of wellness consumers in Westernized cultures like the US, UK, Canada and Australia, typically valued privacy in a spa. Now, however, there's a craving for connection and shared experiences, with wellness as an overarching pillar. Shared social spaces which were already popular among European and Asian cultures are much more in demand worldwide. As a result, spas and wellness centers are expanding their offerings beyond typical spa treatments and investing heavily in hydrothermal bathing areas that allow people to be more social. This is a case of "what's old is new again" with operators recreating and modernizing the popular bathhouses, banyas, onsens and Roman bathing facilities of our past. A bonus? These facilities require minimal labor (attendants vs. therapists), so operators can serve more guests at a lower cost but also a higher profit (see typical ROI chart in Chapter 3).

Communal bathing experiences range from the simple—like a rustic sauna situated lakeside and followed with the refreshing cold plunge of the natural waters—to the complex and sophisticated new urban bathhouses popping up in cities across the globe. The latter boasts an array of facilities, including multiple saunas, steam rooms, hamams, salt therapy rooms, snow rooms, and hydrotherapy pools nestled in the heart of a city. One example is the 50,000-square-foot World Spa located in Brooklyn, New York.

Some of these newly opened venues, like urban bathhouses and renovated natural hot springs facilities, have been purpose-designed for communal bathing. While, conversely, preexisting builds, like gyms and fitness centers, are increasingly getting facelifts and refurbishments to add communal bathing options to their amenity lists as a means of enhancing the client experience and improving member engagement.

Urban Bathhouses

In bustling urban areas around the world, a new kind of sanctuary is emerging. These 'third' spaces are neither our homes (the 'first' space) or where we work (the 'second' space). (Admittedly, many of our home and workspaces have merged into one.) These urban oases cultivate community spirit within a wellness sanctuary, offering a spectrum of services that cater to a diverse clientele. Some even go beyond typical bathhouse features and offer a fusion of cutting-edge wellness technologies, such as cryotherapy or touchless massage, with tailored experiences that support personal health and well-being. These innovative clubs and bathhouses are becoming cornerstones of accessible urban wellness and social hubs.

Wellness Playgrounds

The concept of wellness has transcended the traditional spa, expanding into large-scale endeavors from the likes of European-based Therme Group and QC Terme. Therme Group's water parks offer a new breed of family fun and/or adult havens, creating experiences that weave wellness with entertainment and cultural/art offerings. Millions of guests visit Therme Group resorts each year and, as of this writing, the company has ambitious expansion plans for openings in Washington D.C., Manchester, England and South Korea. All these locations aim not just to provide an escape from daily urban stress but to also rejuvenate cities and neighborhoods, attracting wellness tourism on a significant scale.



Courtesy of Barr + Wray Ltd.

A central hydrotherapy pool with adjacent loungers can serve as a central gathering spot in a communal bathhouse.

Hot Springs Resorts Get Refurbed

Historical hot springs are being reimagined to satiate the public's growing interest for holistic wellness. In the USA, a historical California hot springs, Murietta Hot Springs, has recently reopened with quite a bit of fanfare and the promise of maximizing the wellness benefits that the unique thermal waters offer for each guest. While, in Japan, traditional onsen hot springs destinations are being restored to their past glory as tourism hot spots, similarly, in Australia, renovations are transforming traditional hot springs into multifaceted wellness retreats that offer a symphony of health-promoting services. Around the world, these somewhat forgotten historic hot springs sites are being revitalized and adding more wellness to their menus, including access to saunas and steam rooms. (See Chapter 7 to learn more about how hot springs can benefit health, tourism and the community.)

Spas Within a Spa

While large, communal bathing spaces are highly sought after, there's a simultaneous demand for personalized bathing experiences that are tailor-made to a small group's specific needs. These "spas within a spa" are essentially private wellness suites within larger facilities that can be rented out for small or large groups. The above-mentioned World Spa has two such suites for private use, each equipped with its own thermal room that can operate as a traditional Finnish sauna or a more humid Russian banya, not to mention other amenities, like A/V equipment, a lounge, dining area and fully stocked menus and bars. In Germany where public, fully nude bathing has long been the norm, there's now rising popularity for private thermal bathing areas that can be rented by the hour. Both MySpa and MyWellness cater to individuals or groups seeking bespoke wellness in seclusion.

Expert Insight: Communal Bathhouse Design

By Don Genders, founder & CEO, Design for Leisure

Designing an efficient and welcoming communal bathhouse requires more than just an understanding of spatial requirements—it demands a keen insight into the user experience. Such establishments are social by nature, offering both clothed and nude communal bathing areas, the norm in many European cultures. Here are some “insider” tips on bathhouse design from a seasoned hydrothermal specialist:

Changing Rooms: European bathhouses often feature coed changing ‘villages’—enclosures with cubicles that host two doors, separating the ‘dry’ entrance where street shoes are worn from the ‘wet’ exit leading to the bathing facilities. Here, guests don slippers provided by the facility and store their belongings in lockers conveniently located near all exit points. Not only does this setup keep cross-contamination between the dry areas and the wet areas to an absolute minimum, but they also offer total privacy and helps eliminate “pinch points” that can occur when there is a male/female occupancy imbalance.

Space and Features: Spaciousness is fundamental as bathhouses are primarily social environments. The minimum space needed for a bathhouse business model to succeed is in the region of 460 m²/5,000 ft².

Bathhouses should boast expansive bathing areas, replete with multiple saunas and steam rooms, offering varied environments—from the serenity of silent meditative saunas to the animation of Event Saunas with lively Aufguss performances. The inclusion of diverse steam rooms, pools, and plenty of easily accessed relaxation spaces is imperative for guests to cool down between bathing sessions. Cold experiences—be it plunge pools, ice rooms, or cooling rain or drench experiences—should be ample and strategically placed to manage guest flow during peak times.

A well-designed bathhouse will accommodate the essentials: a 20 m² to 40 m² (200 ft² to 400 ft²) event-style sauna, a smaller 15 m² to 20 m² (150 ft² to 200 ft²) sauna for quieter reflection, and an ample steam room space that can also host communal events. Changing areas must be adequately sized for peak capacity to prevent congestion and frustration during occupancy surges. A “changing village” can help mitigate this issue because the occupancy is mixed gender so if more women attend during the day and more men at night, the imbalance is not an issue.

In general, changing areas need to be able to cope with peak occupancy, nothing is more irritating to a guest who has paid for a 2-hour session to waste some of that time searching for somewhere to change and seeking out an empty locker. So if there will be a rush at 5-6 pm and another when those guests leave between 7-8 pm, the changing areas need to be sized accordingly.

Prioritize Relaxation: If a guest spends 15 minutes inside a sauna or steam room, they will spend at least 20 and more likely 30 minutes out of the sauna before entering it again. A cooling experience is short and sharp, so owners/operators need to get the spacial allocation correct: if a guest cannot find a space to relax, it could dissuade them from visiting again and community bathhouses can only survive on repeat business.

Communal spaces need not be excessively large, but they do need to offer a circuit of hot/cold contrast therapy and relaxation, all within close proximity.



Courtesy of CIVANA Resort Spa & Sanctuary
(Photo by Lisa Diederich Photography)

Membership and Community: If you're considering a membership model, it's wise to remember that this can foster a strong sense of proprietorship, making members more willing to readily voice any concerns with the facilities and how they run, especially in contrast to a 'pay-to-play' model. Aim for a balance that fosters loyalty without inviting unwelcome criticism.

F&B Services: Bathhouses are social spaces, considering offering food and beverages on site. If a guest comes straight from work, they may be hungry or ready to enjoy a drink during or after bathing. Alcoholic beverages, like beer and wine, are often offered and can enhance the convivial atmosphere.

EPOS Systems & Time Management: Managing a guest's time is important. If they pay for 2 hours of bathing but spend 30 minutes eating, they may feel short-changed. An electronic point of sale (EPOS) system can mitigate this issue. Guests are issued a fob, linked to a payment card. The fobs are normally attached to a wrist strap, enabling guests to walk freely through the space, claiming a locker, purchasing secondary spend items, such as renting a towel, robe and slippers, F&B items, or paying for additional treatments such as infrared, red-light therapy or cryotherapy.

Another upside to an EPOS (electronic point of sale) system: the time spent in the F&B area can be automatically deducted from the bathing time they've purchased through a tap-in/tap-out system. Fobs can also be used for product purchases, and therapist-led treatments, with a single checkout transaction at the departure point. This can often be a turnstile-type control, where a card payment is taken by the machine. One member of staff can supervise multiple checkout points and deal with any guest queries.

Outdoor Spaces: These are hugely valuable and come with a relatively low cost in terms of maintenance and management, yet they can be a prime attraction, especially in urban environments where guests may live in high-rise buildings with little or no quality access to open space and, in a high-temperature thermal bathing environment, in colder months, a cool walk in fresh air after a hot sauna will be hugely invigorating.

Gyms Add Wellness Hubs

In the US, your only option for thermal bathing was often a sad, disused sauna at the local gym, typically installed as an afterthought and buried in the bowels of the basement or locker room. Today's savvy gym and fitness center operators are keen to become a community's 'third' space, giving members much more than a weight room, cardio machines and classes by incorporating comprehensive wellness features that go beyond traditional exercise routines. Los Angeles' Heimat is an example of club that provides a unique blend of fitness training with rejuvenating saunas, cold plunge pools, and meditation spaces, promoting a balanced approach to health. Another example is Groundfloor in San Francisco which integrates its fitness offerings with wellness therapies like cryotherapy and hot tubs to enhance recovery. Canada's Altea Active takes a holistic approach, combining a state-of-the-art fitness facility with a broad array of wellness, from spa services to nutritional counseling.

Communal Bathing in Longevity Clinics

As aging 'well' becomes a mainstream mantra and the quest to put more life into our years versus simply adding more years to our lives, longevity clinics (or wellness centers) are on the rise with new, high-tech facilities announced almost daily. This is particularly true among the wealthier demographic who can afford personalized assessments, such as genetic testing, hormone evaluations, metabolic profiling and advanced imaging tests that help clinicians and coaches create personalized health blueprints. But what's relevant in the context of this guide is that more and more of these clinics also offer the tried-and-true benefits of hydrothermal bathing and hot/cold contrast therapy. Among the high-tech medical equipment, don't be surprised to find a communal wellness area with some of the basic features found in a typical bathhouse.

Communal Bathing Features to Consider

Here we get into the heart of what these communal bathing areas offer, focusing on the bathing experiences found in a modern communal bathing area. At a minimum, these facilities must provide guests with a way to get hot, a way to cool down, and an area for the all-important rest and relaxation phase of thermal therapy. That means a sauna or steam room at minimum, a cold-water feature (or simply the ability to walk outside into the crisp, natural air) and enough seating to accommodate the number of guests that can be using the thermal areas at any one time.

Going beyond the basic offering means considering different types of heat experiences — high heat, mild heat and warm — to make the facility attractive to a wider audience. Some guests are not lovers of the hot, dry heat of a sauna, and, instead, prefer a soft sauna (which offers a much milder experience) or even a hybrid sauna that includes an infrared therapy component. It's also important to consider that varying age groups and demographics will have differing tastes in bathing experiences, and, of course, extreme heat can be counter-indicated for the elderly, those who are pregnant and even younger guests.

Traditional bathhouses in Europe and Asia have a long history of providing varied heat and cold experiences to appeal to a wide range of preferences. Think of it as the Goldilocks effect: everyone is looking for the experience that feels “just right.”

Additionally, there are nice-to-have features to consider. For example, snow is a gentler alternative to a cold plunge or ice bath, while a pleasant aromatherapy steam room or inhalation room will delight guests in sometimes unexpected ways, while a dedicated cryotherapy room or floatation experience offers differentiation for a property. And, while “ice baths” may be all the rage thanks to “Wim Hof” and social media feeds from certain influencers, it’s recommended that you proceed with caution when it comes to the cold exposure on offer. These features can be risky for several reasons: submerging in icy waters is not something everyone should do to their body (there are risks involved and not nearly enough studies on the topic) and, until there is a truly commercial option, ice baths are not only difficult to operate, but also to keep clean and hygienic.

Thermal Bathing Areas: Function and Design

The following pages focuses on thermal bathing cabins and rooms (such as saunas and steam rooms) found in a typical modern spa. It includes a comprehensive overview of the functionality and health benefits of the different types of thermal cabins and outlines special considerations required to create spaces that not only please the user, but also comply with accepted health and safety regulations.

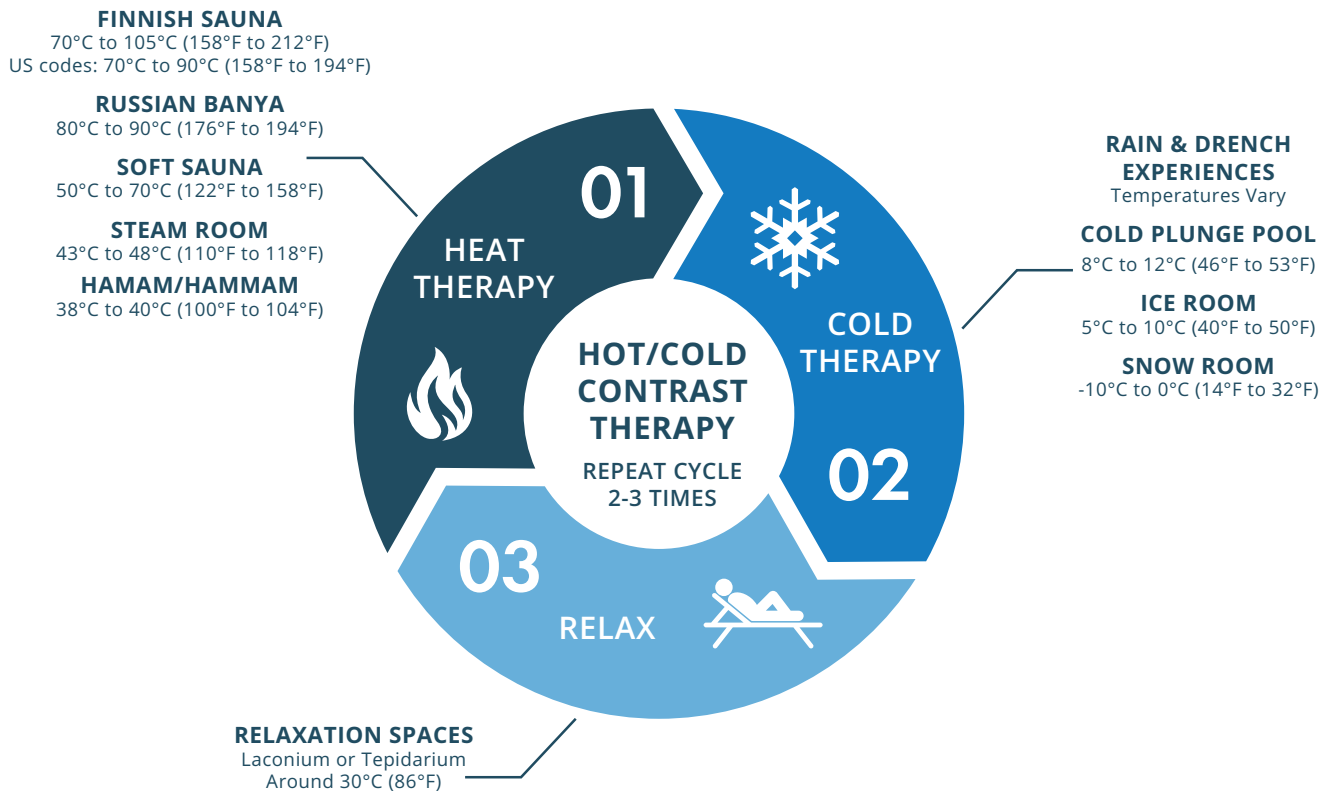



**SAUNAS ARE
HOT & DRY**

Courtesy of Hôtel Les Haras, Agence Jouin Manku, © Nicolas Mathéus

Saunas

Finnish Sauna, Russian Banya, Hybrid Sauna & Soft Sauna

There are several different styles of saunas popular today. The traditional and most common are Finnish saunas and Russian banyas (“banya” actually means “bathhouse” in Russian, but the term has been adopted to refer to the sauna-like room in the banya). While various sauna types all run at slightly different temperatures and humidity, they are closely related in style, construction, usage and health benefits.

Sauna Types

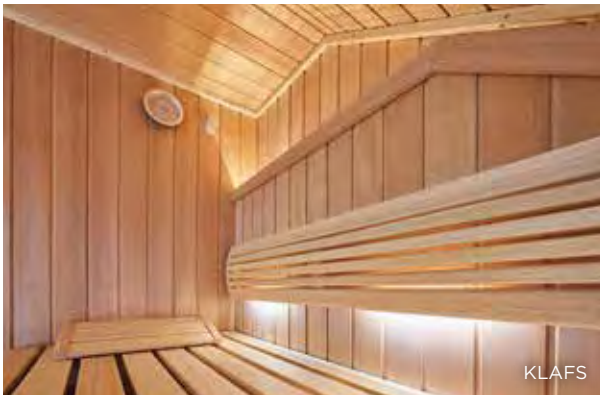

KLAFS

Finnish Sauna

Temperature: 70°C to 100°C (158°F and 212°F);
US code dictates lower temperatures for commercial use: 70°C to 90°C (158°F to 194°F)

Humidity: 5% to 15% at level of second bench;
3% to 10% at level of third bench



KLAFS

Hybrid Sauna

Temperature & Humidity: Same as Finnish sauna
in traditional sauna mode; in infrared mode: 35°C
to 40°C (100°F to 104°F), humidity: 55%



World Spa

Russian Banya

Temperature: 80°C to 90°C (176°F to 194°F)

Humidity: 60% to 70%



CIVANA Resort Spa & Sanctuary

Soft Sauna

Temperature: 50°C to 70°C (122°F to 158°F)

Humidity: 45% to 56%



Courtesy of Nizuc Resort & Spa (DFL & KLAFS)

Finnish Sauna

Traditionally, a simple timber cabin with a heat source radiating warmth from the wood-clad walls via heated stones.

Overview

A traditional Finnish sauna is an integral part of a hydrothermal area and is characterized by dry heat that typically ranges from 70°C to 100°C (158°F to 212°F). Generally constructed from durable woods, the interior holds a heater with stones that, when splashed with water, produce löyly—steam that increases the room’s humidity. These cabins are designed for high heat and low humidity, offering a deeply satisfying sweat experience.

How Finnish Saunas Work

A heat source radiates warmth from wood-clad walls via stones that are heated in an electric or gas sauna stove, or, in traditional installations, by log fires.

Saunas typically have two or three different levels of benches to provide room for as many people as possible and also offer varied temperature zones—as the heat will be significantly stronger at higher levels. The benches are wooden and constructed of specialist timber that is chosen for its low thermal conductivity and high laminar strength. The benches have a lattice design with broad slits to allow the air to circulate well throughout the sauna.

Infusions of water bring out an increase in humidity, subjecting the body to a short, but powerful, heat stimulus. Traditionally, a small wooden tub full of water and a ladle was used to pour water over the hot rocks. In addition, the water was often infused with birch twigs to give it a pleasant fragrance—birch was also believed to improve the immune system and open skin pores. In modern installations, automated water dosing systems are often used, and the infusions are typically oil essences in a wide range of scents that offer different aromatherapy stimuli for body and mind. In addition, there are safety and efficiency benefits associated with automated dosing systems, including the avoidance of over-dosing fragrance and controlling the amount of water that is used, preventing unnecessary wear on the heat source and avoiding any water puddling.

Designing & Building a Finnish Sauna

Heat Source

Sauna Stove: Heat comes from specially sourced stones—typically deep igneous, plutonic rocks capable of absorbing and emitting high levels of heat. They are heated in the sauna stove, traditionally by a wood fire but, more often, by electricity or gas. The size of the sauna stove is determined by how many kilowatts per cubic meter of heat is required—a calculation that must be done by a wet-area spa specialist. For example, the power requirement of the heater increases if the sauna has any windows or if glass is used within the design in general. If this is the case, there can be a potential health and safety issue for guests.

Airflow is crucial in a sauna to ensure that the heat from sauna stove circulates. Because heat rises, the higher benches will be hottest.



Courtesy of KLAFS

Materials/Construction

Structure: A soft, sustainable wood that is resin-free is recommended in classic sauna design—common choices are pine, hemlock, spruce and cedar. When choosing wood, note that minimal knots are preferred, as they can act as hot spots and cause uneven heat radiation.

Benches: A hard, low-thermal-conducting wood is required for the benches. Aspen, obeche or poplar are good choices, as they will not split and conduct minimal heat so will avoid burning the skin. Benches should support a minimum of 200 kg/440 lbs per linear meter or 134 lbs per linear foot.

Ceiling: Should not be higher than 200 mm (8”) above the head of the bather when sitting on highest bench.

Door: Traditionally made of wood, but design trends have moved towards all glass (must be tempered safety glass). Door sizes can vary depending on application and building codes, particularly in relation to access for the disabled. Interior door handle must be wood so it doesn't become too hot to the touch.

Windows: Though not traditional, windows and/or glass fronts are becoming more common in modern saunas. Of course, this can change the level of insulation and radiation provided by an all-wood cabin; however, they have architectural and aesthetic merit and can allow bathers to feel more comfortable by delivering more visibility.

Floors: Saunas should be constructed on level, pre-tiled floors. If the walking distance between the door and benches is greater than two meters (or over six feet), installing a removable wooden floor or underfloor cooling system is recommended in order to keep guests' feet comfortable.



Common Mistakes in Sauna Builds

- Using the walls of the building when constructing sauna: walls of a sauna must be independent and have a cavity between them and the building walls to avoid condensation
- Installing lighting that is not resistant to the intense heat of a sauna
- Incorrect ventilation that does not provide correct airflow
- Installing door handles on the inside of the sauna made of material that conducts heat; therefore, scorching bather's hands
- Purchasing a residential sauna for use in a commercial setting—these saunas aren't designed to the same standards
- Using the wrong building materials so that the sauna doesn't function correctly or has a short life span
- Not accounting for disabled access in a comme



Courtesy of Maybourne Riviera Spa (DFL & KLAFS)

Curved benches are rare in saunas but give the room a welcoming, communal aesthetic.

Design Considerations

Size/Space: When designing saunas for commercial applications, consideration should be given to personal space and a minimum of 600 mm (under 2') should be allowed for each person sitting. Bathers also like to lie down in a sauna so it should ideally accommodate a two-meter-long (or over six-foot-tall) person.

Audio/Visual: Consider both lights and sounds to enhance the experience. In commercial builds particularly, audio is used to help break the often-uncomfortable silence you can have when entering a closed space with strangers. There are heat-proof speakers specifically designed for this usage, as well as specialist equipment that links both light and sound output.

Illumination: Lighting choices are fairly limited in saunas simply due to the fact that it has to be resistant to extremely high operating temperatures, especially in the higher section of the sauna, where heat is strongest. There are specifically designed specialty products available for use in saunas, including sconces, crystal glass diffusers and fiber optic lighting. Standard lighting equipment can also be sourced for installation below the first bench level, as heat is less of an issue.

Ventilation: It is essential that saunas are properly ventilated to keep a continual flow of oxygen in the cabin. An air extractor point is located close to the bottom of the cabin to take the cooler, more humid air out, usually via a duct built into the wall panel that will discharge the air at roof level. Fresh air will be delivered directly into the heat source, ideally exchanged and refreshed seven to 10 times per hour.

Special Considerations: Users of the sauna must be able to monitor temperature, relative humidity and the duration of their sauna experience. This makes the inclusion of a thermometer, a hygrometer (used to measure moisture content) and a timer imperative (an 'hour glass' measuring appropriate time segments is ideal).

Using a Finnish Sauna

Type of Use

Saunas are traditionally used to relax and ease muscle tension, as well as boost circulation and improve the immune system.

As one of the hottest therapy cabins in the hydrothermal spa, saunas should be used in conjunction with cold— this can be anything from a cold shower, an ice fountain or a “roll in the snow” in a snow room or via a snow shower. A warm, ankle-deep footbath (outside the sauna cabin) should also be considered for equalizing body temperature. (The small amount of flesh and fat on the feet, combined with a large number of blood vessels, allows them to get cold and hot faster than any other body part, so a footbath will help regulate the body’s temperature.)

Health Benefits

The alternation of heat and cold (also called contrast therapy) ensure that a good supply of blood is pumped through the veins, helping to flush out toxins from areas of the body that aren’t normally given the ability to do this (namely the skin and subcutaneous tissues). The immersion in both hot and cold is also believed to train the immune system, and regular sauna users rarely suffer minor infections and colds.

How to Use

- A proper sauna session will take 90 minutes
- Remove clothing, jewelry and contact lenses
- Prior to sauna, users must shower and fully dry themselves to remove any film on the skin that can delay the onset of sweating (ideally, a foot bath should be used)
- Once in the sauna, it’s ideal to lie down so that the entire body is within the same temperature zone; if you must sit, sit with your feet up on the same bench you are sitting on
- First sauna session should last eight minutes to 12 minutes (depending on how the body reacts); followed by cooling off 12 minutes to 20 minutes
- Cool off first in the air, then rinse off the sweat with cold water
- The first session can be followed by two more sessions, and you will note that your body will visibly sweat more rapidly during the second and third sessions
- After the final sauna session, it’s important to rest and cool off your body completely



Courtesy of Fairmont Spa Century Plaza (DFL & KLAFS)

Tiered benches in a sauna aren't just aesthetically pleasing, they serve a purpose by keeping the feet even or above the stove to avoid dreaded cold zone. If a users feet are cold, it's very difficult to generate perspiration.



Courtesy of KLAFS

The Secrets of Finnish Sauna Design

Löyly or Perfect Steam

The concept of “Löyly” or “perfect steam” refers to the optimal balance of heat and humidity in the sauna. Löyly actually refers to the steam that is generated when water is ladled onto the hot sauna stones. This is considered an essential part of the sauna experience, enveloping the room and its occupants in moist warmth thought to increase relaxation and purification.

In Finnish tradition, löyly is more than just physical steam; it's also tied to a spiritual and social aspect of sauna-going. There is a strong cultural respect for the sauna and the act of löyly, and there are certain informal rules and customs about how to behave in a sauna and how to produce löyly.

The ideal löyly is said to be achieved when the steam is strong and intense, but not so hot that it is uncomfortable or suffocating. It should be thick and moist, with a pleasant aroma. And, importantly, it should be evenly distributed throughout the sauna so all occupants can enjoy it. In the context of building a sauna for a hydrothermal spa, following these cultural practices will ensure authenticity and respect for Finnish traditions and experience. Getting the löyly right is all about creating the kind of atmosphere and experience that embodies the essence of Finnish sauna culture.

When Finns talk about a sauna experience, you'll hear them ask this question: “Was the löyly any good?” Various technical and design aspects of a sauna affect the quality of the löyly (from the number of stones present and the amount of water ladled onto them to the size/shape of a sauna room), let's explore them.

The law of löyly dictates that feet should always be even with or above the rocks in the stove to avoid the dreaded cold zone and cold toes. The height of the roof should be no more than two fists above the head of bathers on the upper benches, ensuring that the whole body can be engulfed in heat and steam. These seemingly insignificant details are INCREDIBLY important to the overall sauna experience.



Excessive CO2 can build up fast in a sauna. This graphic was in an article raising awareness about dangerous CO2 levels in poorly-ventilated saunas. The spike in CO2 is an actual measurement from one of the saunas monitored. (saunologia.fi/how-co2-affects-sauna-air/)

Minimize CO2, Maximize Good Löyly

You can't get good löyly if you're sitting in a hot sauna inhaling carbon dioxide (CO2), a surprisingly common issue especially if ventilation is not taken seriously. The primary purpose of sauna ventilation is to remove the airborne contaminants we don't want to breathe. CO2 is a waste product from our bodies that is carried in our blood to our lungs where it becomes airborne when exhaled.

CO2 diffuses very quickly, something that is a good thing in many circumstances: CO2 doesn't stay in your immediate surroundings long, and, instead, dissipates into the air, never getting too concentrated where you are standing and talking. However, the diffusion is not effective in a small space like a sauna where we are quite literally breathing in one another's exhaust.

The more volume per person a sauna has the fewer negative effects from CO2. For example, if you have twice the volume per person then CO2 levels rise about half as fast. Conversely, if you have half the volume per person then CO2 will rise a double the rate.

Without proper ventilation, CO2 hangs around in the upper area of a sauna, where the bather's heads are. Suffice to say, this is not considered good löyly and can even be dangerous. It's certainly detrimental to overall wellbeing and underscores why you should always engage a sauna specialist to ensure proper ventilation practices are followed.



Courtesy of Pfalzblick Dahn (KLAFS)

Good löyly is more than just steam; it's also tied to a spiritual and social aspect of sauna-going. A beautiful setting will also encourage a positive sauna experience.



Courtesy of WorldSpa, Brooklyn, NY (Photo by Brian Berkowitz)

Russian Banya

Overview

The term Russian banya literally means Russian bathhouse, but the term has been adopted to refer to the sauna-like room found in a Russian bathhouse. It's almost identical to a Finnish sauna in design and purpose, however it can have higher rates of humidity and bathers are encouraged to hit themselves or another person with “veniks” or bunches of dried branches and leaves from white birch, oak or eucalyptus trees to help improve circulation. In addition, there is usually an antechamber next to the banya for socializing, playing games and enjoying refreshments.

How to Use a Banya

- A traditional banya will have a washing room for showering before entering the banya
- Remove clothing, jewelry and contact lenses
- Do a five- to 10-minute session, followed by a cooling-off period either outdoors or in cold water
- During the second session (or “second sweat”), veniks, or bunches of dried branches and leaves from white birch, oak or eucalyptus, may be used to hit bathers (this can be done by yourself or another person) in order to improve circulation
- During the cooling-off period, bathers often sit in an antechamber next to the sauna, socializing, playing games and having refreshments



Courtesy of CIVANA Resort Spa & Sanctuary
(Photo by Lisa Diederich Photography)

Soft Sauna

A soft sauna (or biosauna) offers multiple heat environments, providing an option for those who prefer a milder form of heat and more steam.

Overview

Unlike traditional saunas, a soft sauna (also sometimes known as a “biosauna”) offers a subtle thermal therapy journey, embracing guests with its comforting warmth and tranquil ambiance. With temperatures no greater than 70°C (158°F) and a delicate infusion of 65% humidity, this oasis provides a sanctuary for those seeking a milder form of heat than they might find in other thermal rooms.

The look and feel of a soft sauna is very similar to a traditional Finnish sauna, but these are steamier cabins and are typically infused with aromatic scents designed to caress the senses, promoting deep relaxation.

Beyond relaxation, the soft sauna is said to provide similar benefits as a traditional sauna, including improved circulation and skin rejuvenation, respiratory support and mind-body balance. Soft saunas are suitable for individuals of all ages and fitness levels, including those who may be sensitive to high temperatures or have health conditions that restrict exposure to extreme heat, making this a feature to consider when building a large hydrothermal area.



Courtesy of KLAFS

Hybrid Sauna



A hybrid sauna has all the makings of a traditional Finnish sauna, with the added therapeutic benefits of targeted infrared treatments.

Overview

At the heart of the hybrid sauna lies the traditional Finnish heater, radiating high heat and creating the quintessential sauna environment. As guests settle onto the classic wooden benches, they will also encounter infrared heating elements discreetly weaved into the space, offering targeted heat therapy to address specific wellness needs.

When the infrared heating elements are in use, offering targeted therapy that penetrates deep into the skin to alleviate muscle tension and enhance relaxation, the sauna heater runs in a lower-heat mode, enabling guests to enjoy the infrared therapy for longer periods of time.

The benefits of a hybrid sauna is that it offers a “best of both worlds” solution: the therapeutic benefits of targeted infrared treatments and the high, hot heat of a traditional Finnish sauna. Operators can determine which experience to offer guests throughout the day.



Courtesy of Awana Spa at Resorts World
(Photo by Meg Blair)

Event Sauna

Large-scale, event saunas are becoming more popular as guests embrace guided, social sauna experiences.

Overview

These specially-designed, large-scale saunas typically accommodate at least 10 people (the largest in the world hosts up to 300!). In addition to housing more bodies than is typical, event saunas also need to provide enough space for an attending Sauna Master to perform the “Art of Aufguss” or to lead group experiences, like meditation or breathwork.

Aufguss (loosely translated from German as “infusion,” describes the act of pouring water on the hot stones of the sauna heater, something a sauna attendant would typically handle) has evolved from its humble beginnings into an engaging performative art display, complete with high-tech sound systems and light shows. The popularity of Aufguss in Europe has borne an entire industry and community, that culminates in an annual Aufguss World Championship.

While event saunas offer a new way to connect with-and delight-current and future guests, there’s another more tangible benefit: a new revenue stream. For each performance, you’ll charge an additional \$20. If capacity is 100 per day and you’re running at 50%, then a simplistic calculation is: $50 \times \$20 \times 2 = \$2,000/\text{day} \times 365 = \$730,000$ additional annual income.

Unique Design Attributes

The Heater Is the Focal Point

The focal point of an event sauna is always the sauna heater, which should be creatively clad and illuminated for maximum visual impact. There needs to be adequate room for Sauna Masters to perform, so good space between the heater and the first bench is required. The sauna heater itself must also be designed specifically for Aufguss, ensuring rapid reheating of the rocks after each dramatic, infusion of water and/or aromatic ice balls by a Sauna Master. Ventilation to the heater is also essential in keeping the room well oxygenated.

Theater-Like Seating, Sound & Lighting

Benches in an event sauna must be at least two tiered, the lower level being deeper to allow guests to sit comfortably in front of the legs of guests sat on higher levels. High-quality audio/visual equipment is imperative. Speakers are 'club quality' and capable of high volumes with powerful sub-woofers hidden under benches (of course, they must be able to withstand the heat of the sauna).

Theatre-style lighting is also required, but it can't take the intense heat of the sauna, and must be specially rigged on trusses above the sauna and projected through double-glazed glass panels in the ceiling.

Unique Control Room

An adjacent control room, with a viewing window into the sauna, not only accommodates the racks that house the computers and equipment required to run the dedicated audio/visual displays, but the window gives a technician a clear view of performance cues.

Event saunas require enough space for an attending Sauna Master to perform the "Art of Aufguss" or to lead group experiences, like meditation or breathwork.





STEAM ROOMS ARE HOT & HUMID

Temperature: 43°C to 48°C (110°F to 118°F)

Humidity: Up to 100%

Courtesy of Fairmont Spa Century Plaza



Courtesy of Faena Hotel, Miami Beach (Photo by Nik Koenig)

Steam Room

Also Known as a Caldarium, Sudatorium or Steam Bath

Steam rooms can reach 100% relative humidity, creating a different type of heat than that of a sauna.

Overview

The caldarium is the Roman precursor to the steam room (also known as steam bath). This was the hottest room in the ancient Roman baths and also had some of the highest humidity rates and air moisture saturation (i.e., steam). This room was heated by an underground furnace known as a “hypocaust,” essentially an under-floor heating system that piped hot water throughout the Roman baths. The fire source was typically located just below the caldarium, hence making it the hottest room in the baths, and, above the fire, a pool or cauldron of water resided and acted as the heat source for the room—delivering both heat and steam.

The modern steam room is unique in that it reaches 100% relative humidity—which gives it the element of steam/fog. It should be noted that in France, a steam room is called a “hamam”—this can cause some confusion as a traditional Turkish hamam or Moroccan hammam is not equivalent to a steam room (though smaller, private, hot rooms off the hamam have very similar attributes).



Courtesy of ESPA

Unlike saunas, steam room benches are often on a single level because the temperatures are much more consistent throughout the cabin.

Due to the high moisture, steam rooms must be constructed of waterproof materials. One option is foam building boards with reinforced cement coating that will create a waterproof tank, prior to being finished with other water-resistant materials, such as porcelain tile, large custom ceramics, granite, or even acrylic. Thermal insulation provided by foam boards saves not only energy by reducing the working hours of steam generators and the amount of heating required, but it also reduces the maintenance costs of this equipment.

Unlike saunas, steam room benches are often on a single level because the temperatures are much more consistent throughout the cabin, but a two-tiered bench system can also be used. Continuous surfaces (stone or large-area heat storage ceramics) are a great choice, but if opting for mosaic, be sure to use grout that is specifically designed to withstand heat and water.

Because of the constant steam, the interior of this room isn't often seen so it's worth considering function over aesthetics when choosing the materials in a steam room.

What makes steam rooms so compelling is the damp air they provide—when fine droplets of water come into contact with the air, they provide a negative, energizing charge. Bathers absorb these negatively charged oxygen ions, which can stimulate the metabolism, bringing about increased energy and even claims of fat burning or weight loss. To increase both relaxation and health benefits, aromatherapy is often added to modern steam rooms.

Designing & Building a Steam Room

Heat Source

Steam Generator: A steam generator creates steam, which is introduced to the cabin by natural pressure caused by the expansion in the evaporating chamber; the steam travels through an insulated copper pipe and should enter the cabin silently via an open outlet. During the heat-up phase, steam is supplied to the still-cold steam room, increasing the relative humidity and the temperature. The room climate in a steam room is governed/controlled by the set-point temperature of the room, which is usually 42°C to 47°C (110°F to 118°F). Once that temperature is reached, the steam production is interrupted until the room has cooled down by 2°C to 3°C (around 36°F). When the steam production is off, it is recommended the air extraction fan should be activated. This allows the steam generator to restart steam production quickly and helps keep a constant room humidity of 100%. It also provides visible steam in the room. If the humidity does not reach 95% to 100%, the steam won't be visible.

Steam production is governed by the room's temperature, and a re-ignition of steam is activated when the temperature falls below the desired value, so it's important to be aware that overheating the floors or benches can unbalance the steam generation.

Steam generators are housed in a plant room. These can be designed into the structure or housed separately. It's important to get professional advice on the location and size of your plant room.



Courtesy of The Spa at Palms (DFL)

The Principles of Immersion Heating

Heater elements are placed in a closed cylinder and connected to alternating current. The cylinder is filled with tap water, fully demineralized water or partially softened water. Heat generated by the heater elements increases water temperature to approximately 100°C (212°F). If fully demineralized water is used, the feed water is practically free of minerals. This ensures long life for the cylinder and heater elements since virtually no mineral deposits can settle or build up, ultimately, this should minimize the number of service/maintenance checks. If tap water is used, some of the minerals that dissolve in the water will settle in the cylinder as solids. These scale deposits are removed by periodic flushing or use of a heavy-duty blow-down pump. The generated steam has a temperature of about 100°C (212°F) and minimal positive pressure (“pressure-less” steam). It is also virtually demineralized and germ-free.

Common Steam Generator Types

Resistive Heat



Electrode



The two most common steam room generators are electrode, which pass electric current through a stainless steel element immersed in water, and resistive heat. Where possible, electrode- or resistive heat-type generators with cleanable and reusable cylinders are recommended. Their integrated drain pumps and flushing systems reduce lime scaling, and this leaves a smaller footprint combined with a more environmentally friendly operation. However, a key contributor to this decision is the type of water available on site, as a resistant-heat steam generator does not rely on water quality and can, therefore, be easily maintained. The water's conductivity depends on its inherent minerals and hardness or softness. Water quality must be tested to determine if an electrode steam generator or a resistive heat-type generator generator should be chosen.

Steam Inlets: The point at which the steam enters the room should be obvious to bathers and in a position that doesn't risk injury from either the hot steam or the nozzle itself. Steam inlets should not be located under benches or allow steam to enter the steam room under pressure. Note: Refer to Chapter 8 for more detail on ventilation and climate control.

Materials/Construction

Structure: One of the most efficient forms of constructing "wet" thermal rooms is using prefabricated, polystyrene panels that are cement-coated and reinforced with fiberglass on both sides. These panels are moisture- and mold-resistant, have high insulating values and are quickly and easily assembled on site. Other materials like acrylic or aluminum/glass can also be used.

Walls/Floors: Made of standard waterproof and mold-resistant materials; floor will have adequate drainage and slope for the water from Kneipp hoses, porcelain tile, granite, large-format, custom ceramics or even man-made surfaces.

Benches: Ideally continuous stone or large-area heat storage ceramics; can be heated to body temperature from 36°C to 37°C (98.6°F).

Ceiling: Plastered and painted; steam- and etheric oil-resistant plaster; should not be higher than 200 mm (8”) above the head of the bather when sitting on highest bench.

Door: Tempered safety glass doors, clear glass to allow for un-obscured viewing. Handles should be stainless steel and doors should push open for easy exit. Doors should be retained, closed by a simple roller-catcher mechanism.

Design Considerations

Size/Space: Bathers like to lie down in a steam room so it should ideally accommodate a two-meter-long person. When designing steam rooms for commercial use, consideration should be given to personal space. The minimum amount you should allow for each person sitting down is 600 mm (under 2”).

Benches: Continuous stone or large-area heat storage ceramics are recommended to minimize the number of joints on surfaces that bodies will come in contact with. This is beneficial for both comfort and hygiene.

Audio/Visual: Steam-proof speakers provided by a specialist wet-area manufacturer can be used. Consider color-changing lighting.

Illumination: LED spots in ceiling or under-bench lighting systems are recommended for visibility and durability, while fiber-optic lighting in the ceiling is sometimes used for mood enhancement.

Steam Room Components (Schematic Layout)



Ventilation: Fresh air should be introduced with steam flow and it's crucial to maintain air quality through proper air exchange rates: for example, the Austrian ÖNORM M 6219 standard requires that steam room air is exchanged 6x each hour. An air outlet in the roof will remove warm air from the steam room to ensure continuous steam supply and a stable temperature control. Ideally, exhaust ducts should also be installed directly above the exterior of the steam room doors to remove steam that escapes when opening and closing the door.

Special Considerations: Though it's not uncommon to use under-floor and bench heating, be aware that too much heat in the steam room will unsettle the temperature/steam balance. Nevertheless, the surfaces that bathers sit or lie on should ideally be set at an approximate surface temperature that equals body temperature.



Common Mistakes in Steam Room Builds

- Overheating room with floor and wall heating—this will negatively affect humidity/steam
- Installing room temperature sensors in the wrong position, resulting in room not reaching 100% humidity
- Failing to install temperature sensors and other cabling within electrical conduits for ease of maintenance
- Steam outlets dangerously positioned, causing injury to bathers
- Not installing enough correct lighting/illumination; lighting needed to clean the unit is often forgotten
- Failing to install a way to flush/clean benches (a Kneipp Hose, for example)
- Use of wrong materials, such as gypsum boards or plywood, and/or wrong closing mechanisms
- Tiles poorly installed with incorrect grouting—so they easily pop off when exposed to heat and moisture
- Undersizing plant room and/or putting it in the wrong location (i.e., too far away)
- Incorrect ventilation and temperatures
- Using wrong slopes and drainage designs
- Failure to install water softeners in locations with hard water
- Incorrect installation of aroma injection into the steam pipe
- Ceilings too flat with no gradient, causing water to drip on guests
- Benches are often installed at an even level; however, this will result in an accumulation of water. Instead, a 2% decline is recommended to avoid water puddling

Mineral deposits from the water can wreak havoc on the steam generator and other components, so look for easy-to-clean systems that seek to minimize these issues, and, instead of relying on tap water, think about using demineralized or soft water.

Consider installing a Kneipp hose for cooling off inside of the cabin. This feature will double as a hygienic way of rinsing benches before and after use.

Using a Steam Room

Type of Use

Deep relaxation, detoxification and general wellbeing are key reasons for the enduring popularity of steam rooms. Though not as hot as a sauna, steam rooms offer similar benefits at a less intense heat. In traditional Roman baths, this was the hottest area the bathers had access to and, similar to a sauna, should also be used in conjunction with cooling treatments—such as a cold plunge pool (frigidarium), ice room, snow room or shower.

Health Benefits

The intensive warmth causes the muscles to relax, and limb and joint pain is noticeably reduced. Steam rooms are often used to help those that suffer from rheumatism or arthritis. The high humidity also delivers positive moisturizing effects on the skin. As well, the alternation of heat and cold, using a cold plunge pool or snow room, ensures that a good supply of blood is pumped through the veins, helping to flush out toxins and regulate the blood.

How to Use a Steam Room

- Take a shower before entering the steam room—it helps with hygiene, plus, it's best to remove dirt and grime before sweating
- Remove clothing, jewelry and contact lenses
- Up to three sessions inside the steam room is recommended, each one slightly shorter than the previous
- Rest between sessions for 12 to 20 minutes
- When finished let yourself gradually cool down; drink plenty of water
- Clean after use, rinse off space with water; a Kneipp hose is usually provided for this purpose

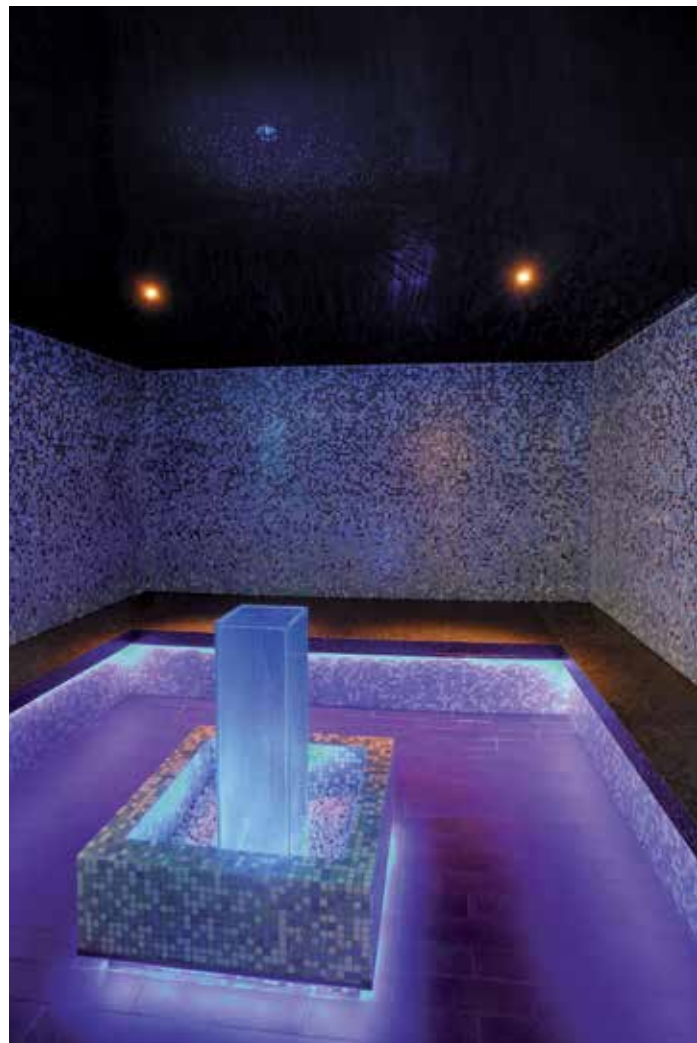

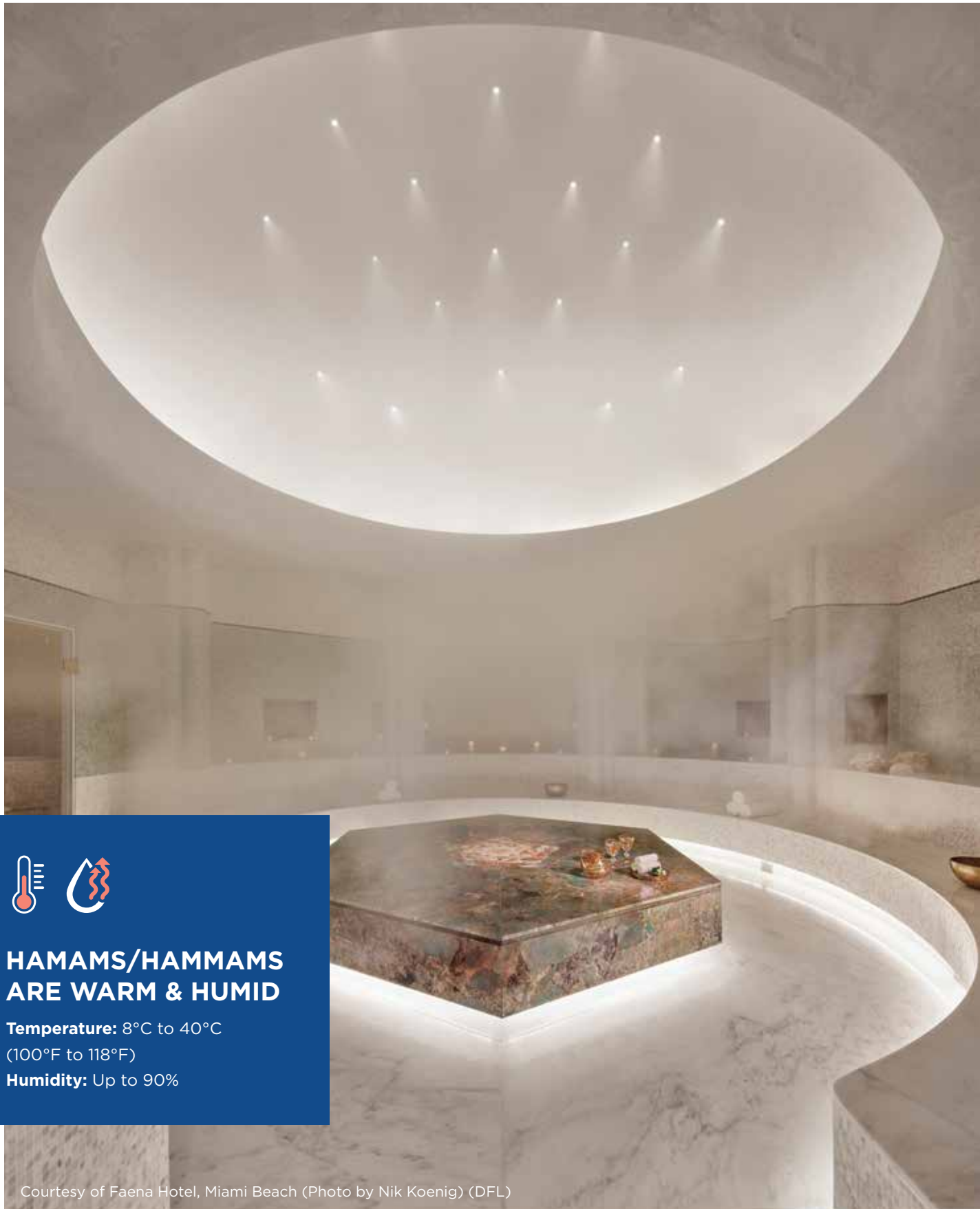

HAMAMS/HAMMAMS ARE WARM & HUMID

Temperature: 8°C to 40°C
(100°F to 118°F)

Humidity: Up to 90%

Courtesy of Faena Hotel, Miami Beach (Photo by Nik Koenig) (DFL)

Turkish Hamam & Moroccan Hammam

The Turkish Hamam Experience

Heat/humidity followed by a vigorous full-body scrub (with a “kese” or rough mitt); water rinse; a soap massage and rinse; hair wash and rinse. Many modern versions follow that cycle with a full-body oil massage outside of the hamam.

The Moroccan Hammam Experience

Heat/humidity; followed by a full-body, sticky, black soap massage and exfoliation with a “gome” glove; and then often a terracotta foot stone rub and rinse; a clay/mud application to body, face and hair (and rinse or soak). Also often followed by argan oil application.

Overview

The word “hamam” literally translates as “bathroom” in Turkish and refers to the entire Turkish bathhouse. There are two principle styles of hamams—the Turkish hamam and Moroccan or North African hammam. Both derived from the original Roman bathhouses (built after the Romans conquered the respective regions). Upon the Romans’ departure, the Turks and North Africans evolved their hamams/hammams to better suit their cultural needs—including the fastidious cleansing of the body (and soul) as a component of the Muslim faith. A strong byproduct of this communal bathing was the socializing element.

A Turkish hamam is a large domed structure with a central room (sikaklek) in which the belly stone (göbek tasi) takes center stage. The belly stone is traditionally where attendants scrub and clean bathers, and there are often small rooms off the large central space that were used for wealthier customers to be washed in private—these design concepts are frequently used in modern hamams for private treatments. There are a large number of basins (called kurnas) around the room that supply water for washing and rinsing, and plenty of bench space where bathers can wait for treatments or relax and socialize. A Moroccan hammam is similar to its Turkish relation but has retained more of the traditional Roman bathing ritual—sending the bather on a journey through smaller chambers with varying temperatures (like the Roman journey through the laconium, caldarium, frigidarium and tepidarium).

Note that “hamam” is sometimes confusingly used as a generic term to describe a steam bath or a steam room. This is particularly common in France and the French-speaking territories of Switzerland. For clarity, this reference book refers to the hamam as a bathing structure (including communal and treatment areas).



Courtesy of Barr + Wray Ltd.

In a traditional hamam, there are a large number of basins (called kurnas) around the room for washing and rinsing, and plenty of bench space where bathers can wait for treatments or relax and socialize.

Designing & Building a Hamam/Hammam

Heat Source

Traditionally, a hypocaust provided warm under-floor heating, replaced by hot water “hydronic” systems as piped plumbing systems were developed. Often the floors were heated higher than body temperature, requiring bathers to wear wooden sandals (which became serious fashion statements in the heyday of Turkish hamams). A modern hamam will use hydronic heating, a system of pipes heating the floor, walls and benches to maintain a high radiated temperature.

Unlike a steam room, the hamam does not operate at close to 100% humidity. A high level of humidity (50% to 80%) is required, however, and this was traditionally generated by the large amount of water being used in the treatments and evaporating off the hot floors and seating/treatment surfaces. Today’s guests aren’t always comfortable with the public bathing rituals so massage, exfoliation, shaving and hair washing may be undertaken in private rooms. This means humidity levels often need to be augmented in other ways—either through a steam generator or water-misting system with appropriate venting and air circulation systems.

These are connected to humidity and temperature sensors, allowing for accurate control of the hamam environment.

Materials/Construction

Structure: One of the most efficient forms of constructing “wet” thermal rooms is using prefabricated, polystyrene panels that are cement-coated and reinforced with fiberglass on both sides. These panels are moisture- and mold-resistant, have high insulating values and are quickly and easily assembled on site.

Walls: Porcelain tile, large-area heat storage ceramics, marble, granite, or even man-made surfaces like Avonite, Silestone and other agglomerates.

Floors: Prefabricated tileable floors with integrated gradient and warranted waterproofing. Stone tiling with integral drains set into the floor to avoid pooling of water and to aid cleaning and maintenance. Slip-resistant surfaces are essential (following the German DIN 5109-7 standards for barefoot traffic, classification B, is ideal).

Benches/Göbek Tasi: Finished using continuous stone surfaces (or similar man-made surfaces); if opting for a special pattern or design, use grout that is resistant to water and heat. Note the göbek tasi is often still present, usually as an acknowledgment to tradition rather than a dedicated treatment surface, but keeping this traditional “amphitheatre” style is popular and provides a large surface for lying down.

Ceiling: Plastered and painted, steam- and etheric oil-resistant plaster. May be tiled/ include ornamentation for aesthetic considerations. Height is not as critical as in a sauna or steam room because the radiant heating in walls, floors, and benches is adequate to keep a guest warm and comfortable, but heat rises. Therefore, we encourage the use of heat recovery equipment to harness heat that collects in high-ceiling areas using air-to-air heat exchangers. Heat can be easily recycled this way, while still discharging the stale air and odors from the hamam.

In ancient Roman bathhouses, a hypocaust system was used to heat the rooms—similar to today’s hydronic systems.

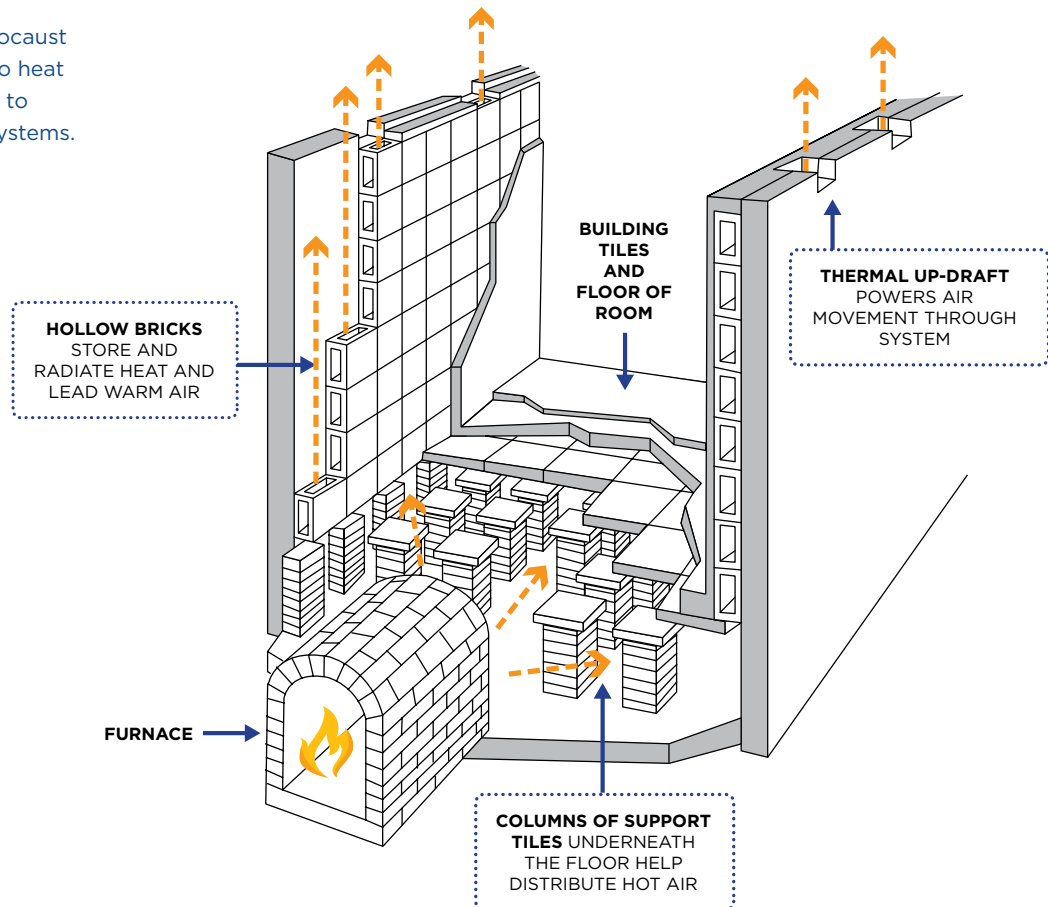

Lighting: Traditional hamams have piercings in the domed roof, sometimes in quite intricate shapes, allowing sunlight to shaft through these “elephant eyes,” which often have diameters of 10 cm to 15 cm (around 3”). Modern lighting technology can be used to replicate these ideas, from simple, round downlights to complex systems where lighting projectors shine through to replicate the shafts of sunlight in traditional settings.

Design Considerations

Size/Space: The ceiling should be designed to include a traditional domed cupola roof or vaulted ceiling. It may be appropriate for heat recovery systems to be installed to re-circulate the heat at higher levels.

Aromatherapy: Automatic essential oil dosing system.

Audio/Visual: Low-level audio with water/steam proof speakers.

Illumination: Soft, indirect lighting from LED and fiber optic.

Ventilation: Fresh air supply and air extraction will ensure good oxygen levels. The recommended air turnover is 4-7 changes per hour, with an incoming air temperature between 18°C to 24°C (97°F to 108°F).

Special Considerations: An authentic atmosphere is achieved when the room is finished in traditional Turkish “Iznik”-style tiles and Carrara Blanco marble; while North African hammams favor a traditional plaster finish called “tadelakt,” which isn’t advised in commercial applications. Although there are some excellent modern plasters that can achieve the same effect, dramatic designs have been created in modern hamams using less traditional types of natural stone and tile.



Common Mistakes in Hamam/Hammam Builds

- Confusing a hamam with a steam room—these are different experiences and different room types
- Improper building materials causing issues with cleaning and maintenance
- Forgetting or not providing enough space for plant room
- Poor drainage, causing water to pool on floors
- Not installing temperature and humidity sensors in easily accessed, maintainable conduits
- Placing steam outlet in positions where bathers get injured by the hot steam
- Not installing enough lighting/illumination—often forgotten is the lighting required to clean the unit
- Failing to install a way to flush/clean benches (e.g., a Kneipp hose)
- Ventilation is vital in all thermal rooms and should be in line with the recommendations in Chapter 8



Courtesy of Sommerhuber

The göbek tasi sits at the center of a traditional hamam and is often used as a dedicated treatment surface. It is usually finished in a continuous stone surface (or similar man-made material). If opting for a special pattern or design, use grout that is resistant to water and heat.

Using a Hamam/Hammam

Type of Use

Cleansing was the original purpose of the hamam— and today hygiene still plays a central role. Typical treatments include an exfoliating rub with a “kese” (Turkish) or “gome” (North African) mitten, a soap massage (black soap in North Africa) and hair wash. In addition, socializing and relaxation are the key goals of most bathers.

Health Benefits

The hot air temperature and warmth of the treatment surface (whether a traditional belly stone or a modern heated treatment table) relieve muscle pain and promote mental relaxation, while the high humidity produces intense sweating, which leads to a detoxifying cleansing.

How to Use a Traditional Hamam/Hammam

- Take a shower before entering hamam/hammam
- In a public bath, you will be given a “pestamal” (a towel with fringed ends)
- Enter the dry, warm room to start the bathing process
- When moving to the hot room, women usually remove their towels, while men traditionally keep theirs on. Women and men bathe separately.
- Use the basins (“kurnas”) to cool down with cool water while in the hot room
- Await cleansing rituals, including exfoliation, hair washing, shaving, etc. (Foam plays a large role in these rituals. The foam can be created by a hamam/ hammam master or automated for self service)
- This can be followed by a private massage



**RELAXATION
SPACES ARE WARM
& DRY**

Courtesy of Sommerhuber



Courtesy of Hotel Fritz Lauterbad

Relaxation Spaces

Laconium and Tepidarium

In a traditional Roman thermae, these two rooms would offer respite from the high heat of the sauna and steam rooms. The milder temperatures encourage rest and relaxation between the extremes of the hot/cold contrast therapy of a traditional bathing circuit.

Laconium

The laconium is a relaxing, dry heat environment with a temperature below the aggressive levels of a Finnish sauna. In Roman times, it was seen as the dry, sweating room of the thermae, adjacent to the caldarium steam room with its higher temperature.

Temperature: 38°C to 45°C (100°F to 113°F)

Surface Temperatures:
approximately 34°C +/- 2°C (93°F +/- 3°F)

Humidity: 10% to 20%

Tepidarium

In ancient Roman baths, the tepidarium had a central role as a relaxation and body care room. Typically the air temperature would be warm (tepidus) with constant radiant heat, at a higher temperature, coming from the stone walls, floors, bench seating and recliners.

Temperature: 30°C to 40°C (86°F to 104°F)

Surface temperatures:
approximately 34°C +/- 2°C (93°F +/- 3°F)

Humidity: 20% to 40% (not controlled)

Overview

Both these relaxation rooms offer a relaxing, dry heat environment with temperatures below the aggressive levels of a Finnish sauna. These rooms provided a more relaxing, less-intense experience allowing for a longer stay—usually 20 minutes but up to an hour.

These rooms were often the central hub of a Roman bath, linked to other hot and cold rooms. Bathers would use a tepidarium or laconium as a focal point for warming up the body, engaging in body treatments (oils and cleaning), as well as relaxation. In a modern spa, this area is usually referred to as the “relaxation room” and will often have individual stone/tile recliners and bench seating with thermostatically controlled electric or hydronic heating. Of course, many “relaxation rooms” today feature normal beds or cushioned loungers, but they often have an element of warmth to them.

An alternative to heated, body forming loungers are soft, warm beds—water beds offer a nice alternative to traditional mattresses.

Relaxation spaces also play an important role in many spas for guests who have contraindications (such as pregnancy or cardiovascular conditions) that prevent them from using the hotter rooms. Offering this option makes the spa more inclusive.

Keep in mind, a Laconium-inspired relaxation room can also include water features like Kneipp hoses to wash away perspiration after using other spa features like a sauna or steam room.

Benches and recliners have additional hydronic or electrical heating to increase the radiated heat/infrared heat level. The benches and recliners are often fixed (non-moveable) fittings.



Courtesy of Sommerhuber

Providing enough space for relaxation is often the most overlooked aspect in a hydrothermal build.



Courtesy of Barr + Wray Ltd.

Designing & Building a Relaxation Room

Heat Source

The heat is radiated evenly from the walls and floor as well as the reclining surfaces when using heated benches or loungers. In Roman times, this was provided by under-floor hot air in the hypocaust. In modern times, air temperature is controlled by the central heating system (warm air ducts) with electric or hydronic under-floor heating.

An under-floor heating system adds considerable flexibility to the heat source, and, although initially more expensive to install, has cost efficiencies over a longer term.

Benches and recliners have additional hydronic or electrical heating to increase the radiated heat/infrared heat level. The benches and recliners are often fixed (non-moveable) fittings in a laconium, while a tepidarium-style relaxation room may feature soft cushion or water-filled loungers instead.

Materials/Construction

Structure: Generally ample in size, with enough room to seat six to 16 people. The interior of a laconium is tiled to provide both the radiated heat surface and a pleasing aesthetic, while a relaxation room (or tepidarium) can be built from more traditional materials..

Walls/Floor: Usually of ceramic tile/stone to maximize the radiated heat, and, are often more ornate because they are dry, and bathers spend a great deal of time in them. In a Laconium, the floor will have adequate drainage and slope for the water from Kneipp hoses. Prefabricated, tileable shower bases with integrated gradient and sealing are also an option.

Benches/Loungers: Often made of stone and tile for the same radiated-heat benefit. Loungers are contoured to allow for comfortable relaxation with individual thermostats to control radiated-heat temperature. Loungers are often two-piece—a base pedestal and a horizontal reclining surface, often tiled with mosaic to enhance the aesthetic appeal of the room. Other surfaces include stone and ceramic, which minimize joints—improving comfort and facilitating cleaning. Tepidariums will also have heated, soft fabric loungers when style dictates.

Ceilings: Can be tiled for effect, but, otherwise, coated in waterproof paint. **Door:** A self-closing door is required to retain the heat in the room.

Door: A self-closing door is recommended to retain the heat in the room.

Design Considerations

Walls/Benches/Floors: As a relaxation room is a steam-free environment that bathers remain in for extended periods of time; the interior usually reflects a luxury environment and is often opulent in its tiling and fittings.

Size/Space: The overall size is generally dependent on the other bathing facilities/overall capacity of the spa. Individual loungers need to encourage relaxation usage and should be approximately 700 mm x 2,000 mm x 900 mm (28" x 79" x 35 1/2") (w x l x h).

Audio/Visual: Low-level and ceiling lighting, together with discreet music, can enhance the relaxing atmosphere. Care needs to be taken with placement of equipment which needs to be accessible for maintenance. Tepidarium does not have extreme heat/ cold or specific water applications so the construction does not necessarily have to be as robust as other bathing areas.

Special Considerations: Surfaces and fittings should be waterproof, and electrical elements must be sealed and protected (with circuit protection/circuit breaker capability) to allow for cleaning and maintenance. As a relaxation area, a key focus is the design aesthetics, including audio and lighting. Creating privacy with the use of screens and curtains is common. The room needs regular cleaning to ensure acceptable hygiene standards so drainage system should take this into account. Guests may be using this space to relax after the intense heat of a steam room or sauna so chilled refreshments are often offered in this space, even if it is only a chilled water fountain.



Common Mistakes in Relaxation Room Builds

- Room lacks the privacy guests desire or is not big enough or too bright for relaxation
- Choice of loungers uncomfortable—too small, too hard, not ergonomically shaped
- Use of incorrect building materials
- Allowing noise from plant rooms or other treatment rooms to infiltrate relaxation area
- Incorrect ventilation and temperature
- Aromatherapy is often overlooked because there is no carrier (like steam or water), however, aroma systems that use evaporation can be used in Tepidariums
- Guests can consider their rooms “boring”, consider adding a small fountain or aromatherapy fog fountain to encourage guests to spend enough time relaxing

Using a Relaxation Room

Type of Use

Relaxation spaces are used both to warm up the body before using other thermal areas and to cool down following periods of time spent in a sauna or steam room. Also for warming up after using a plunge pool, cold shower, ice room or snow room. They are also used as a way to relax and recharge body energy after a treatment. These rooms provide a counterpart to other hot and cold treatments and will be the key relaxation areas in a modern spa.

Laconiums also have cold-water Kneipp hoses available to wash away perspiration, creating a hot-cold purification and detoxification cycle.

Health Benefits

The radiant heat offers deep tissue/muscle penetration to soothe and relax individuals. The heat-based treatment of heated relaxation loungers improves blood flow, increases metabolism, promotes mental and physical relaxation and reduces stress. Aromatherapy oils are often used. Applying essential oils such as lavender, eucalyptus and citrus to the skin can also enhance the positive effects of the heat—promoting mind-and-body re-generation.

How to Use a Relaxation Room

- Use this area to acclimatize to higher temperatures prior to using other bathing rooms
- Wear a towel to protect the skin from the hot reclining surfaces, as well as for hygienic reasons
- Relax in the room, following hot/cold and water/ dry treatments
- Use individual audio/other sensory facilities (if provided) to enhance relaxation and feeling of wellbeing
- Relaxation is a key part of the hot/cold contrast therapy cycle-repeat usage of relaxation room frequently



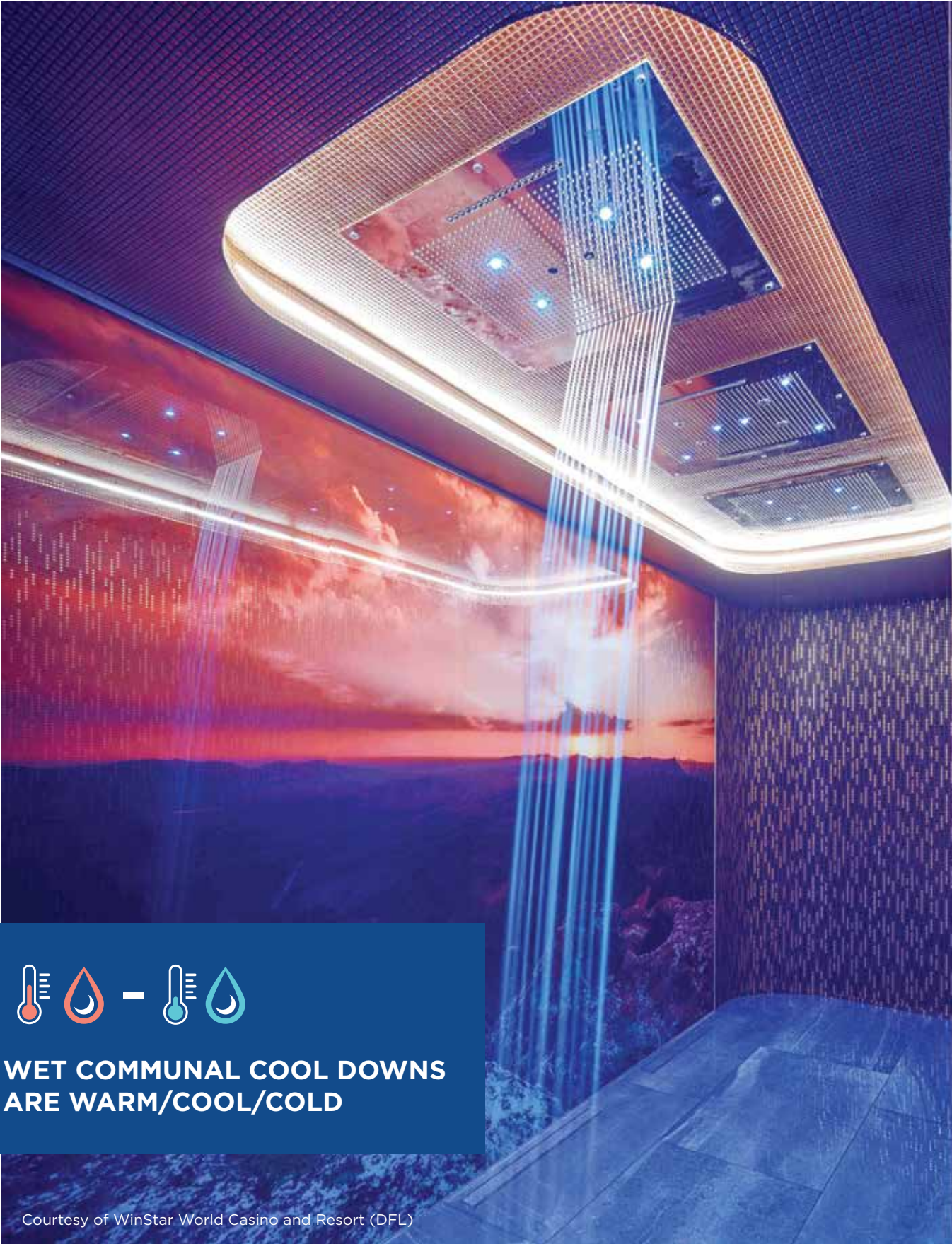

**WET COMMUNAL COOL DOWNS
ARE WARM/COOL/COLD**

Courtesy of WinStar World Casino and Resort (DFL)



Courtesy of Bestzeit Lifestyle & Sport Hotel

Wet Communal Cool Downs

Rain & Drench Experiences & Foot Baths



Providing social, communal areas within a hydrothermal area is essential to the guest experience.

Overview

Warm and cold waters have always been an integral part of the traditional thermal bathing ritual—allowing the body to cool down after a hot sauna or steam room.

In modern facilities, these communal cooling water treatments take many different forms and offer differing functionality. For example, one popular offering is a simple shower or something more elaborate which might be referred to as an “experience shower” (note: we have renamed “showers” as “Rain & Drench Experiences” for this edition because the strict codes associated with commercial shower installations can cause unnecessary red tape for these common spa features which are typically designed for a quick walkthrough or drench versus a full shower experience.) Other communal water treatments include foot baths.



Courtesy of Barr + Wray Ltd.

Rain & Drench Experiences

Overview

Rain & Drench Experiences are often peppered throughout a hydrothermal spa area, offering a combination of water, sound and smell that evokes a natural “event” for the bather, with themes ranging from “emotional” and “energetic” to “waterfall/deluge” and “monsoon” to many in between.

Why We Use “Rain & Drench” vs. “Shower”

In this edition, we have chosen to avoid using the word ‘shower’ when discussing cooling experiences involving falling water. As standards come more in line with the Americans with Disabilities Act (ADA), we have opted to call them Rain & Drench Experiences.

This is a deliberate choice designed to distinguish between traditional bathing showers, which people use privately for personal hygiene and which require important accommodation for disabled users, including a drop-down transfer bench and multiple grab rails.

Within a hydrothermal spa area, guests with access needs, particularly those using wheelchairs will inevitably use special wet area chairs, enabling the guest to use the chairs in wet features without the need to transfer. Therefore, as long as the enclosure of the experience is sized to allow access, with a 1725 mm (68”) for new US buildings or 1525 mm (60”) for existing properties to allow for a turning circle, then the experience will meet code.

If this feature is referenced as a ‘shower’ on design drawings, the reviewer is likely to reject it as not compliant with accessibility standards.

Designing & Building a Rain & Drench Experience

Heat/Cold Source

Hot and cold water are piped to the showerheads with a looped supply to provide the bather with instantaneous hot or cold water on demand. Sufficient water pressure/capacity is essential to maintain the multi-head flows.

Materials/Construction

Structure: Size and shape (square, round, snail, etc.) depends on the site layout. Specially designed, prefabricated, polystyrene panels that are cement-coated and reinforced with fiberglass on both sides, should be moisture-resistant and waterproof.

Walls/Floors: Usually tiled; drainage capacity/ floor slope is a key element of a successful design. Prefabricated, tileable shower bases with integrated gradient and sealing are a good option.

Design Considerations

Size/Space: Enclosures are typically for a single person. Size is approximately 140 cm x 140 cm x 250 cm (4' 6" x 4' 6" x 8') if square and 120 cm (4') in diameter if round. However, a rule of thumb is to never create a shower smaller than 100 cm x 100 cm x 250 cm (3' x 3' x 8') or larger than 200 cm x 200 cm x 250 cm (6' 6" x 6' 6" x 8'). Height can vary between 220 cm to 300 cm (7' to 10'). As experience showers don't usually have doors, be aware that a fine mist spray can travel out of the enclosure into surrounding areas.

Rain & drench experiences combine water, sound and smell to evoke a natural "event" for a bather.



Courtesy of WDT Werner Dosiertechnik

Audio/Visual: Music and sounds are generated by an integrated MP3 player with memory card and activated through the control panel. Common sounds include tropical rain, thunder, waterfall, birdsong, waves/sea, river/stream, etc. A water-resistant, mounted speaker(s) on the ceiling provides the audio. LED lighting provides visual cues to support the experience— dark skies, sunset, sunrise, etc., and smells like fruit, flowers, spices, and sea, can be added to enhance the experience.

Aromatherapy: A dosing system linked to the control panel provides the fragrance. This level of technology requires adequate space for placement and easy access for maintenance, as well as robust waterproofing. In addition, it's imperative to ensure that the aroma does not flow back into the local water supply.

Special Considerations: Positioning is usually in proximity to heat treatment rooms. Additional features, such as simulated wind/breeze, can also be added, requiring additional ventilation.



This image illustrates a rain experience and its required dosing system. (Courtesy of WDT Werner Dosiertechnik)



Common Mistakes When Building Rain & Drench Features

- Not having enough water pressure to make experience operate correctly
- Water quality—hard or dirty water can damage equipment, increase maintenance frequency and create a bad guest experience
- Improper sealing of electrical and hydraulic equipment within shower
- Improper sealing of push buttons against the tile often leads to damaged buttons
- Incorrect calculation of draining slope and draining capacity
- Shower cabinets can be too big, causing an unpleasant shower experience
- Plant room forgotten or too far from showers
- Badly executed aroma dosing. New regulations in Europe insist that a non-return device is installed to avoid the aroma getting sucked back into the main water supply—which could be dangerous to guests.
- General overuse of aromas

An alternative type of foot bathing experience with aquapressure benefits.



Courtesy of Dornbracht International

A rain and drench experience consists of a lot of components in a relatively small structure, so placement, access and waterproofing are key aspects of a successful installation—as is the overall management of water quality, pressure and drainage.

In order to cut corners or save money, some facilities opt for a “standard” shower, but standing under a cool/cold shower for 30 seconds to 180 seconds, the ideal time required to start the cooling process, can be very uninspiring. The features offered by rain and drench experiences are designed to hold the bather’s interest and act as a distraction; consequently, there is a greater chance of the bather getting the full cooling treatment and deriving maximum benefit.

Using Rain & Drench Features

Type of Use

An essential part of thermal bathing is cooling the body down—this is important for enjoying spa facilities safely and maximizing health benefits.

Typically, the rain and drench experience combines water flow variations, sounds and music, dynamic lighting and even aromatherapy to deliver a multi-sensory stimulus. A key element are waterjets that can be programmed to deliver different experiences. Strong, lateral jets facilitate massage, overhead water buckets deliver a dump of cold water, and water mists gently hydrate. Jets can also be programmed to mimic nature; for instance, rain, thunderstorms, mist and waterfalls. A handheld showerhead is often included for washing before a sauna or steam treatment, as well as for providing additional cooling. Some common themes include Rain Forest, Tropical Rain, Cold Waterfall, Polar Mist, Monsoon, Summer Storm, etc. An individual enclosure often has several pre-programmed themes that last between 30 seconds to three minutes.

A trend gaining in popularity is rainwalks or tunnels. This gives users a uniquely active experience because the bather is led through the tunnel/walk through automated programs that lead him/her from zone to zone. The programs are either activated by a push button or photo sensors at the start of the walk/tunnel.



Health Benefits

Body cooling after heat treatments ensures a good supply of blood to the skin and internal organs, helps to flush out toxins and closes skin pores. The multi-sensory approach also adds stimulation of the senses—driving other emotional responses, ranging from excitement to contentment. This offers a unique, new element to the overall wellness benefits.

How to Use a Rain or Drench Feature

- Pre-programmed experiences are selected from a push-button control panel
- The user stands in the water jet area as the program runs
- Different programs can be experienced
- Handheld heads/Kneipp hoses can be used for individual cleaning/cooling requirements



Benefits of Aquapressure

Aquapressure (targeted water massage) has similar benefits as acupuncture, helping blood circulate more freely through the body, the flow of energy is stimulated and mobility can be improved. Aquapressure targets and relieves tensions by warming the body up and then easing muscular and emotional tensions. The results are similar to a massage and can help relieve back pain, tension headaches, sleeplessness and anxiety caused by muscular imbalance.

Energizing Massage Shower

Targeted warm or cold water combined with a powerful massage relaxes and loosens neck and back muscles while creating positive energy to start the day.

Relaxing Massage Shower

Less pressure and warmer water helps bathers unwind and release the tensions of the day.

Photos courtesy of Dornbracht International



Courtesy of WDT Werner Dosiertchnik

Foot Baths

Foot baths offer an opportunity to cool down and rest between thermal rooms. They are also important for warming up feet prior to a treatment, which enables your body to generate a sweat more easily.

Overview

Foot baths are an important part of European spa and wellness culture – not only does taking alternating hot and cold water foot baths reduce stress levels and regulate the body’s temperature (fun fact: without warm feet, your body won’t be able to generate a sweat as easily when in the sauna or steam room), the foot bath area also offers a great opportunity for socialization while in a thermal area.

Modern foot baths should allow for alternatively enjoying warm or cold foot bath: at the press of a button, a basin will be filled with either warm or cold water. Once the water level is reached, a foot spa should automatically stop filling and begin blowing air into the basin to stimulate the foot reflex zones. The bubbling starts automatically for a programmable time. Once it goes through this cycle, the bather’s feet can remain in the water a little while longer and then the basin will be automatically emptied.

When a cycle is completed, the whole system is disinfected—including drain piping, air piping and the basin—making it completely hygienic for use by several people one after the other.

An alternative to foot baths is the Kneipp Walk (outlined in Chapter 6).



COLD IMMERSION THERAPIES ARE COLD & WET

Courtesy of TechnoAlpin

Whole-Body Cold Immersion Therapies

Cold immersion is an age-old tradition in hydrothermal bathing. The Finns are among the first known to actively use hot and cold contrast therapy as part of their cleansing ritual. After spending time in a hot sauna, bathers would leave the cabin, sweating profusely, for a “roll in the snow” that not only cooled them down but also cleansed the dirt from their bodies.

The tradition may have evolved out of a basic need to cool down and get clean, but the Finns also enjoyed the invigorating properties of hot and cold contrast therapy which has been shown to promote heart health, detoxification and even reduce blood pressure.



Parkhotel Egerner
Höfe Mangfall Spa

Ice Room

Temperature: 5°C to 10°C (40°F to 50°F)

Humidity: Not controlled



Cold Tub (Ice Bath)

Temperature: 10°C to 15°C (50°F to 60°F)

Humidity: Not controlled



TechnoAlpin

Snow Room

Temperature: -10°C to 0°C (14°F to 32°F)

Humidity: 25%

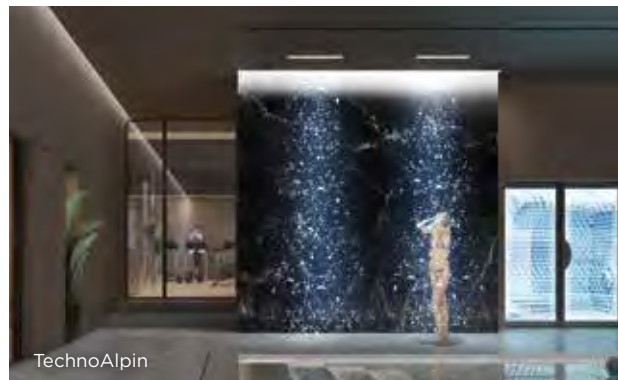

TechnoAlpin

Snow Shower/Snowfall

Temperature: Room temperature will vary

Humidity: Partially controlled



Courtesy of PALAIS THERMAL, Bad Wildbad

Ice Room

Overview

An ice room offers a refreshing counterpoint to heat therapies. Typically maintained at temperatures just above freezing, a cold room will often have a central ice fountain from which guests can apply crushed ice to their bodies, but it could also house a plunge pool or an ice bath. The purpose of this space is to stimulate circulation and provide a full thermal contrast experience.

Designing & Building an Ice Room

Cold Source

An ice room consists of a highly insulated room and a separate air cooling system located in or above the room with an external condenser, much like a heavy-duty split air conditioning system. Normally commercial refrigeration equipment is adapted for this purpose. The condenser is located externally up to 50 m away from the internal air handling unit in the ice room. The ice room will operate and maintain temperatures around the 8°C to 12°C (46°F to 54°F) range. It is advisable to have an air-controlled vestibule kept at 16°C (60°F) to minimize heat gain when guests enter and leave.

Materials/Construction

The critical issue is the need for high levels of insulation to keep the cold in the room, with no impact on adjacent spaces.

For Structure, Benches & Ceiling: See Snow Room on page 102.

Walls: A good rule of thumb for wall finishes is to use materials found in outdoor construction or decoration, like glass-fiber reinforced plastic, glass or natural stone. The use of screen-printed glass featuring arctic scenes can help ‘transport’ guests mentally and visually to an icy location.

Floors: The floors should have adequate drainage, and be completely waterproof at all joins. Tiles should have the highest anti-slip rating possible. Floors should always be heated, but more for cleaning, drying and maintenance purposes as during operating hours, the cold air falling on the floor will overcome any heating system.

Design Considerations

When designing an ice room, other features can also be added such as ice fountains or even cold misting heads to add extra dimensions to the bathing experience. Animal skins, real or fake, can be strewn around for the comfort of guests.

Size/Space: Ice rooms are never large as guests don't linger more than a few minutes so 15 m² (160 ft²) should be adequate

Ventilation: The room should be completely insulated, not ventilated.

Special Considerations: See Snow Room Special Considerations on page 104.

Using an Ice Room

Type of Use

Ice rooms are usually placed near the warmer cabins, allowing bathers to enjoy the health and recreational benefits of the cold. The cold air refreshes lungs and airways. Fresh ice from the ice fountain can be used to cool down specific areas of the body.

Health Benefits

The cold atmosphere provides the same health benefits as a plunge pool with the added benefit: inhaling cold air creates vascular dilation in the lungs, an area that is very difficult to reach any other way which, in turn, cools the core of the body the way cold plunges and ice baths cannot, the cooled blood then acts like a cooling coil throughout the body.



Common Mistakes in Ice Room Builds

- Not using highly-rated U-value insulation materials for the walls and ceilings
- Not using anti-slip floor covering inside the Ice room
- Failing to install a drain inside and outside the Ice room in the vestibule
- Overlooking the need for a warm water connection within or nearby the room for cleaning



Courtesy of Modern Minds

Cold Tub (Ice Bath)

Overview

Water conveys temperatures 25% more effectively than air, therefore an ice bath will create a very different physiological effect (and not necessarily pleasant) than an ice room or snow room.

Cold tubs or even ice baths are high on the requested list of, commonly incorporated into hydrothermal spa circuits, is a therapy pool chilled to temperatures between 10°C to 15°C (50°F to 59°F). This feature is designed to enable cold water immersion, which can constrict blood vessels, reduce muscle inflammation and swelling, and stimulate the nervous system, providing a therapeutic contrast to heat treatments. It's utilized for recovery, to enhance circulation, and invigorate the body.

Though ice baths have become increasingly popular, thanks to well-known “biohackers” like Wim Hof (aka the “Ice Man”), it should be noted that these experiences aren't for everyone (especially those with heart issues). Extreme caution is recommended when putting an ice bath in a busy spa due to the extreme “shock to the system” cold water exposure can bring. There are other far more gentle ways to achieve the benefits of cold exposure. This is why ice rooms, snow showers and cold rooms are often preferred in a busy hydrothermal area.



Courtesy of TechnoAlpin

Snow Room

The gentle cooling effect of a snow room is a cool-down experience that most guests can tolerate easily.

Overview

The snow room is a modern alternative and considered a gentler option to the “shock” that comes from plunging into icy waters after a hot sauna or steam room. Advances in refrigeration technology mean that it’s now possible to replicate the traditional Nordic “roll in the snow” in any hydrothermal facility.

Snow rooms offer another benefit: snow simply makes people happy, bringing out their playful, inner child. Cold crisp air combined with having real snow within grasp makes it a one-of-a-kind experience.

Designing & Building a Snow Room

Cold Source

A snow room consists of an insulated room and a separate snowmaking system located in a plant/ mechanical room. Cold air and water are provided by the snowmaking system, which is cooled either by a chiller condensing unit or by another cooling system available in the building.

Today's snowmaking technology produces the equivalent of natural snow with just air and water — there are no added chemicals. Snowmaking is carried out at night so guests can enjoy fresh snow the following morning.

Materials/Construction

Structure: One of the most efficient ways of constructing “wet” thermal rooms is using prefabricated, polystyrene panels that are cement-coated and reinforced with fiberglass on both sides.

These panels are moisture- and mold-resistant, have high insulating values and are quickly and easily assembled on site. Another option for cold rooms are 10-cm metal sandwich plates, powder-coated outside.

Walls: These reflect overall design requirements. Mosaic and other small-format tiling is not recommended as the drastic temperature changes within the room can damage the grout over time. Decorative elements that are temperature stable are ideal. A good rule of thumb to follow is to use materials found in outdoor construction or decoration, like glass-fiber reinforced plastic or glass.

Floors: The floors should have adequate drainage, and be completely waterproof at all joints. Tiles should have the highest anti-slip rating possible.

Benches: Are suggested so that guests can enjoy their stay in the room for the recommended timeline.

Ceiling: Textured/non-drip render complemented by design requirements (tile, etc.).

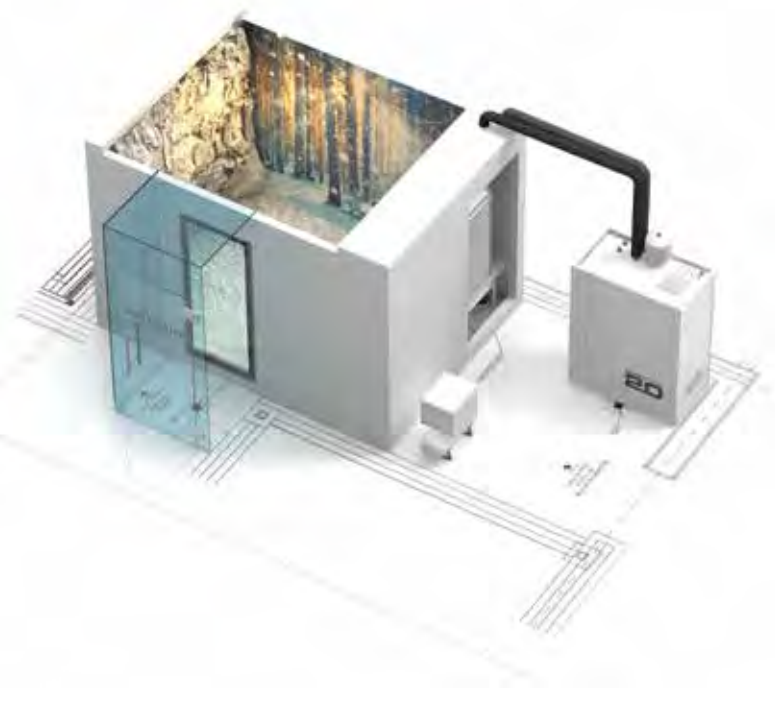

How Is the Snow Made?

Snow is made by simulating the natural formation of snow. The difference is that it's accelerated using special indoor snowmaking technologies. The modern technologies on the market work with a closed air refrigeration circuit system and a nozzle system spraying water and compressed air into the snow room. Only the natural elements of drinking water and air are used for the snowmaking process—no chemicals or biological additives are necessary. Snowmaking is usually carried out at night so that guests can enjoy fresh snow the following morning.

The beauty and delight of a snow room is best appreciated when installed adjacent to thermal rooms for easy access to cold contrast therapy.



Courtesy of TechnoAlpin

Design Considerations

When designing a snow room, it's important to remember that the snow is the feature of the room and abundant amounts of snow should be made accessible to guests. So it's important to include ledges or other decorative elements where snow can fall and rest.

Size/Space: Snow rooms range in size from approximately 4m to 20m (3' to 65'). The snowmaking system is either a separate or partly integrated system that works together with the snow room to ensure the correct temperature and snow production. Various variations of the system are available. All systems combine refrigeration technology with snow making technology. The snowmaking system is located in a plant/technical room and requires additional space (the minimum required is approximately 5 m or 16").

Ventilation: The room should be completely insulated, not ventilated. In case of ventilation, the incoming air would have to be sub-zero and dry, that would require additional air conditioning.



Common Mistakes in Snow Room Builds

- Not using highly-rated U-value insulation materials for the walls
- Not using anti-slip floor covering inside the snow room
- Failing to install a drain outside the snow room recessed into the floor for excess water drainage
- Overlooking the need for a warm water connection within the room for cleaning

Special Considerations: The snow room should be located in close vicinity of heat treatments so that they are integrated into the bathing rituals. Due to the very cold temperatures within the room and the heat penetration from the spa area each time the door is opened, it is highly recommended that a buffer zone be created. The buffer zone should be an area of approximately 2 m (6’). and temperature controlled. This is also more energy efficient as it reduces the cooling necessity of the snow system. The buffer zone can be optimally integrated into the wellness area and is highly suggested especially for areas with high footfall. It is not as vital in private spa settings.

Using a Snow Room

Type of Use

The sub-zero temperatures and snow are a welcome respite to the heat of various other treatments. The cold air within the snow room refreshes lungs and airways. Fresh snow is then used to cool down specific areas of the body and underscore the refreshing effect. Snow rooms are usually placed near the warmer cabins, allowing bathers to enjoy the health and recreational benefits of the cold.

Health Benefits

The near-freezing atmosphere of sof a snow room provides the same health benefits as a plunge pool does with the an added benefit: inhaling cold air creates vascular dilation in the lungs, an area that is very difficult to reach any other way. In colder climates, during evenings and autumn/winter, this cold-air benefit can also be provided with access to outside spaces.



Courtesy of TechnoAlpin

Inhaling cold air creates vascular dilation in the lungs, an area that is very difficult to reach any other way.

Contrast Therapy: The Dr. Thuile Method

Dr. Christian Thuile, Medical Director of the Department of Complementary Medicine at the Merano Hospital in South Tyrol, Italy and author of *Schneesauna – Die Wellness-Revolution (Snow Sauna – The Wellness Revolution)*, has developed a guide on how to most effectively use snow rooms in conjunction with saunas.

The method is based on a number of scientific studies that have assessed bodily reactions to the effects of the cold. The conclusion is that, when used correctly, the hot and cold contrast can lead to a number of health benefits, including reducing fatigue, improving rheumatoid arthritis, pain reduction as well as minimizing muscle soreness after activity and improved regeneration after intense training.

The Dr. Thuile Method is based on the alternating between a heat source, such as a sauna, and a snow room. By following the Dr. Thuile Method, blood vessels extend and contract quickly resulting in improved blood circulation in the entire body. Furthermore, more oxygen and nutrients are transported to cells, strengthening them and benefiting the heart and circulatory system.

After spending time in a hot sauna, the body is fully warmed and muscles are more mobile and relaxed, cramps are loosened, connective tissues are more elastic and pores are opened. Many people experience exertion and fatigue after a sauna experience. Cooling the body down and bringing it back to its natural temperature as soon as possible is a necessary step.

The cold of a snow room is often perceived to be less invasive than a cold or wet option (frigidarium), allowing bathers to spend more time in the area, thereby maximizing the effects. When in the snow room, it is highly recommended that one use the powdery snow to additionally cool the extremities of the body, such as legs and arms. The very cold snow reaches temperatures below 0°C (32°F) and the process of rubbing the snow onto arms and legs assists cooling in those areas. The positive side effect is that one can avoid the intensified cooling on other more sensitive areas of the body. The cold can be specifically applied to assist in reducing inflammation and joint soreness as well.

Immediately after entering a snow room, the body begins to react to the cold, causing vascular constriction or vasoconstriction—a narrowing of the blood vessels—and, in the cold ambiance, the blood flow centralizes to protect vital organs.

The contrasting vasodilation—expansion of the blood vessels—that occurs in the heat of sauna, followed by the vasoconstriction causes increased blood flow to the skin, muscles and tissue. According to Dr. Thuile, this can be particularly beneficial for people with low blood pressure, especially if repeated on a regular basis.

Of over 200 people studied using a snow room in combination with a Finnish sauna, subjects reported improved sleep, significant pain reduction, better moods and an increased amount of energy, relief from stress and pressure, improved breathing, softer skin and a healthier sense of self.

How to Use a Hot/Cold Therapy

- Settle in for three to four minutes; acclimatize to the hydrothermal environment. Loosen up muscles by walking or stretching.
- Warm up for 12 to 15 minutes; dry sauna. Stay as long as comfortable.
- Cool down (three to five minutes for women; four to eight minutes for men). Sit or stand in the snow room. Take deep breaths of the fresh air. Rub snow on arms and legs to intensify the effect.
- Relax for 15 to 20 minutes in ambient temperature; sit or lie down and ensure sufficient liquid intake.



Courtesy of TechnoAlpin

Snow Shower

The benefits of today's snowfall technology is that snow can be produced regardless of a room's ambient temperature; freezing temperatures are not required.

Overview

The sensation of melting snow on the skin is another alternative for bathers looking to cool down after a hot cycle. Snow showers deliver a gentle alternative to traditional equipment and experiences like Kneipp hoses, plunge pools, waterfall showers or crushed ice treatments. Snow showers are either open or closed areas where a continuous snowfall can be generated by pushing a button.

Designing & Building a Snow Shower

Cold Source

When using snowfall snow-making technology, there is no need to cool down the area using a separate cooling system. This new technology means it's possible to use snowfall technology in other areas of a spa, not only in a cold room or a snow room. The snow is simply produced from water and electricity—no chemical additives

are used in this process. A refrigeration generator and a heat exchanger are used to cool the water down, and then freeze it to create nice, light snowflakes. Snow showers can be used in ambient temperatures of up to 40°C (32°F).

Materials/Construction

Snow showers can be integrated in almost any space within a hydrothermal area. Built as either a single unit with equipment mounted on top or as a split unit with the cooling technology residing in an adjacent plant/mechanical room. The latter solution keeps any noise from the snow making away from the guest area.

Design Considerations

There are minimal restrictions regarding the design of snow shower areas: they can be designed as an open space or feature walls made of glass, natural stone or tiles. Sound or light effects can also be integrated.

Using a Snow Shower

Types of Use

This is snow on demand—the bather activates the shower and snowfall begins in approximately 10 to 30 seconds and, depending on personal preference, the shower will last between two to five minutes. Advanced snowfall production technologies produce natural real snow in ambient temperatures ranging between 0°C to 40°C (32°F to 104°F).

Health Benefits

Cooling down the body with a snow shower after exposing it to high temperatures is a gentle alternative to a plunge pool and the sensation of snow melting on the skin has the added benefit of being fun and delightful—providing another positive experience for the bather.

Snow showers are “on demand” features that last between two to five minutes and can be installed virtually anywhere in a spa.

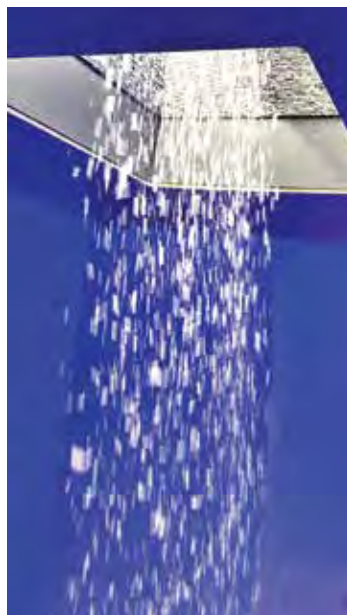



Chapter Five

Specialty Room Design, Treatments & Therapies

This chapter takes a closer look at the various specialty rooms, hydrothermal treatments and therapies found in spas, bathhouses and other wellness facilities. This is a look behind the curtain at the areas and offerings that cater to individuals versus communal bathing and is designed to help readers understand their functions and benefits while providing guidance on the design and configuration of these rooms.

The pleasure and benefits derived from thermal bathing can be further enhanced with add-on treatments and therapies often conducted in private spa areas.

In addition to communal hydrothermal areas, many wellness centers offer specialty rooms for specific hydrothermal treatments, from cryotherapy, floatation and salt inhalation therapy to mud bath rituals, body wraps and scrubs. Additionally, specialist hydrotherapy equipment is also a popular add-on, these can include Vichy showers, hydrotherapy tubs, and Kneipp hoses as stand-alone experiences or added on to other bodywork.

Private spa suites and dedicated wellness rooms in residences are gaining traction, often featuring an array of private thermal therapies—such as saunas, hamams, steam rooms, hot tubs, and experiential showers. These personal havens cater to those seeking the benefits of thermal bathing with an element of exclusivity. This luxurious trend is particularly appealing to couples and friends desiring a social spa experience away from public view, offering personalized indulgence at a premium level.

Specialty Room Design

Treatment Rooms

When designing and configuring a treatment room in a spa – whether for facials, massage or wraps – there are some unique design considerations to be aware of. In general, treatment rooms should have space for a shower, ideally in an anteroom so a guest can shower in private. This also allows the therapist's time to be used more efficiently, enabling them to tidy/clean the room while the guest showers versus vacating the room completely. The treatment surface or receptacle, whether it's a table, tub or dry floatation tank, must be in the center of the room to allow plenty of room for the therapist to access the guest.

In addition, these rooms require the following:

- **Drainage:** Strategically placed floor drain(s) to catch any water run-off from the treatments. Floor drains (DN80) are in addition to any direct drain connections required by specific pieces of equipment and should include an odor cover and wastewater sieve, as well as a demountable grid cover.
- **Floor:** Anti-slip tiled floor with waterproof joints and an incline of at least 2% towards the floor drain.
- **Walls:** Depending on the positioning of the unit inside the room, tiled walls with waterproof joints are recommendable.
- **Shower:** Treatments may require a shower either before or after so a shower should be in the room or in an adjacent anteroom.



Courtesy of Myrthia Thermal Spa

Treatment rooms should be designed for multi-use and allow space for a therapist to maneuver around treatment tables.

Couples treatments are becoming increasingly popular. Installing a hydrothermal spa suite that can accommodate two person is a wise investment for any spa.



WinStar Spa at WinStar World Casino and Resort (DFL)

- **Sink:** Use a “kitchen”-style tap to enable easy filling of bowls that may be used to pour water on the guest during the treatment.
- **Electricity:** Waterproof sockets/receptacles on the floor if the treatment surface/equipment needs power; on the walls for cleaning equipment; and in the cabinetry for any concealed equipment.
- **Lighting:** Indirect, dimmable lighting that is positioned away from the guest’s line of vision to prevent them from being dazzled.
- **Ventilation/Air Conditioning:** To maintain a comfortable environment and correct levels of humidity, wet treatment rooms should be heated to 25°C to 35°C (77°F to 95°F).
- **Floor/Wall Heating:** If used for Turkish massage, floors and walls should be heated.
- **Audio and Speakers:** Either from a central multi-channel system or localized in the room via an MP3 player docking station for a more customized solution. Speaker should be out of the guest’s line of sight if recessed into a wall or ceiling.
- **Cabinetry/Storage:** Units are needed to house specialist equipment, such as a hot towel cabinet or hot stone heater; space should be allocated for consumables that are used in various treatments; storage space is needed for clean and soiled linens; and a sink and prep area is usually required.

Structure/Finish: Built or lined using a foam-cored, waterproof, building board prior to receiving finishes, which can be selected from non-porous, fissure-free marble, granite, tile, specialist plasters or custom made, large-format ceramic panels. The finishes should be easily cleaned and suitable for high volumes of water.

Size/Space: The room must accommodate the treatment equipment, all of which will fit into a space of 1.0 m x 2.5 m (approximately 3’ x 8’), with minimum additional circulation space for the therapist at 0.8 m (2’ 6”) around the treatment equipment, while also allowing space for the shower and cabinetry. An ideal footprint for a room with a separate shower and changing area would be 6.0 m x 2.6 m (around 20’ x 8’ 6”) measured internally.

Spa Suites

Spa suites enable guests to enjoy different types of spa applications in relatively luxurious and private environments, normally attracting a premium price, without having to move around the spa. So, in addition to the positive effects of the treatments, the guest is more relaxed because they will have the luxury of time to enjoy all the equipment at their leisure.

Spa suites are usually designed as “miniature spa areas” in their own right and can include separate rooms/areas for different treatment types and are often designed to accommodate two or more people. What is included in a spa suite is determined by the theme of the spa itself and with consideration to guests’ expectations and needs – some common combinations are as follows:



Sample Room 1

- Small hamam area or sauna
- Shower to rinse off and cool down between treatments
- Two relaxation beds for relaxing after having used the en-suite hamam or sauna
 - These beds can serve a double duty by offering a hydro-massage feature, a fully automatic underwater massage.



Sample Room 2

- A fully automatic massage tub for hydro-massage
- A dry floatation bed used mostly in combination with body wraps
- An anteroom accessible via connecting doors with a sauna/hamam and two relaxation/massage beds.

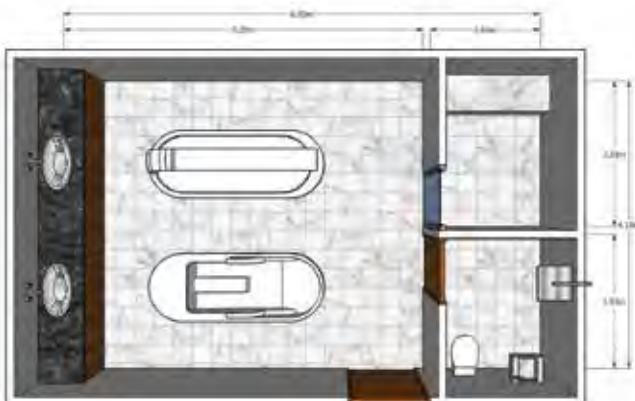

Sample Room 3

- Overhead Vichy/horizontal shower table that can also be used to apply body wraps or dry massages.
- A fully automatic Hydrotherapy tub for underwater massages



Common Mistakes in Specialty Room Builds

- Not paying enough attention to the ergonomics of tables and equipment to create a comfortable experience for both customer and therapist
- Creating difficult to clean areas—instead, make cleaning easy by using flat, smooth surfaces and a removable mattress
- Vichy shower installations must cover a client’s entire body—if some areas aren’t reached, the client will feel unpleasantly cold
- Forgetting to install a shower in a treatment room that will be used for wraps and mud baths
- Inadequate delivery of water—both in terms of pressure and temperature
- Residual water remaining on floor due to poor positioning of drains and slope calculation
- Noise can be extremely disturbing during treatments. This has to be kept in mind when planning both the placement of the treatment rooms (e.g., distance to dressing rooms, bar, restaurant) and the interior design of the rooms.
- Ergonomics for both guest and therapist—do everything to make both parties comfortable, such as choosing options like electrical height-adjustable beds
- Incorrect/insufficient electrical installations
- Incorrect positioning of the equipment inside the room
- Not including inspection openings for technical components when integrating equipment into individual design solutions
- Lack of attention to cleaning and disinfection when choosing the equipment
- Insufficient ventilation of the treatment rooms, especially for wet rooms (e.g., equipped with Vichy showers)
- Insufficient amount of space for storing necessary equipment and products
- Not using corrosion resistance building materials and ventilation pipework that can withstand the saline mixture in a salt/brine room
- Installing spray nozzle in the wrong place, i.e., too close to the extraction fan or too far away from the steam outlet or in the ceiling and not in the wall as the spray jet has to go horizontally into the room.
- Not using sterile brine solution

Specialists Rooms

Halotherapy/Salt Therapy Rooms

In recent years, salt therapy has steadily grown in popularity. The concept originated in Europe when it was observed that workers in salt mines experienced a significantly reduced number of respiratory issues than their counterparts in other mines. Salt rooms and caves are specific treatment rooms that require dry conditions, good ventilation and, most importantly, the introduction of finely powdered salt into the air via a salt aerosol device (also called a “halogenerator”) or as a saline solution from a nebulizing brine vapor. The treatment is passive—the individual sits in a comfortable recliner, often with a blanket and mood music/lights to enhance the state of relaxation.

In addition to salt’s positive impact on the respiratory system—medical studies have shown that salt inhalation alleviates asthma symptoms—it is also embraced by many for its positive effect on skin conditions, with studies showing that salt can improve a variety of skin issues, including decreasing itching, drying small fissures/scratches, and reducing of dermatitis symptoms.

The Dead Sea has attracted visitors for centuries (it was one of the world’s first health resorts) for its healing properties and Dead Sea salt can be found in a wide variety of skincare products. In recent years, Himalayan salt has been hailed for its perceived healing properties as one of the purest forms of salt in the world and is being embraced in massages and salt scrubs—with many salt rooms featuring a wall of pretty pink Himalayan salt blocks. Though these are aesthetically pleasing, they are simply for appearance’s sake and do not provide wellness benefits on their own.



Courtesy of Jumeirah Messilah Beach Hotel

Salt therapy has a positive impact on the respiratory system and is also embraced by many for its positive effect on skin conditions, with studies showing that salt can improve a variety of skin issues.

Cryotherapy chambers are specially designed enclosures for exposing the body to extreme cold temperatures for short periods of time, reducing inflammation and aiding in recovery.



Courtesy of Cryobuilt

Salt Steam Room: A salty sea climate is achieved by spraying fine nebulized brine solution into the room through a fine nozzle. Bathers can relax in a salty, humid room and inhale the hot steam enriched with salt. It's important that both the nebulized brine solution and spraying system is sterile to avoid bacteria and germs.

Dry Salt Inhalation Room: Salt is delivered through a variety of means, including spraying fine, nebulized brine solution into the room through a nozzle, an ultrasonic mist maker or via dry salt.

Cryotherapy Chamber

As the benefits of hot/cold contrast therapy and general “stress” therapy gain traction, cryotherapy chambers are being seen in more spa and wellness centers. These specially designed enclosures are used to expose the body to extremely cold temperatures for short periods of time, typically just 2- to 4-minute sessions. The chambers operate at temperatures ranging from -100°C to -140°C (-148°F to -220°F). During a typical session, an individual steps into the chamber, and their body is enveloped by misty nitrogen vapors or refrigerated cold air.

What Cryotherapy Promises

While there is a lack of research on long-term effects of cryotherapy, the reported benefits include:

- Reduced inflammation and increased recovery
- Pain relief for minor injuries
- Endorphin release - exposure to extreme cold can trigger the release of endorphins, the body's natural mood elevators, leading to a feeling of euphoria and well-being
- Increased metabolism - some claim that the cold temperatures boost metabolism, potentially aiding in weight loss efforts
- Improved skin - increased blood circulation is said to promote better oxygenation and nutrients supplied to the skin

Infrared Therapy Room

An infrared therapy room refers to a space equipped with infrared heaters or lamps designed to emit infrared light for therapeutic purposes without the high temperatures of a sauna (the hybrid sauna on page 65 can be operated as an infrared therapy room). The biggest difference is the heat these rooms provide—infrared is a natural electromagnetic radiation that's not visible to the human eye. Infrared heat is used in medical applications, as it is believed to enhance blood circulation and ease muscle tension, while strengthening the immune system and reducing stress.

How Infrared Heat Works

Long-wave infrared radiation is absorbed by the upper layers of the skin and is assimilated just under the surface where the heat-sensitive nerves—the peripheral nervous system—are located. This warmth is then distributed throughout the entire body by the blood vessels and lymph nodes and is comparable to the pleasant warm feeling experienced from the warming of the sun.

Two types of infrared saunas exist. Traditional wood saunas with integrated infrared lamps (top) feature radiation that is primarily in the shorter electromagnetic wavelength of infrared B; while a heat-storage ceramic sauna (left) emits longer infrared C waves. Experts suggest that shortwave infrared is better for curing specific physical ailments, while longer-wave infrared is beneficial for overall well-being and prevention.

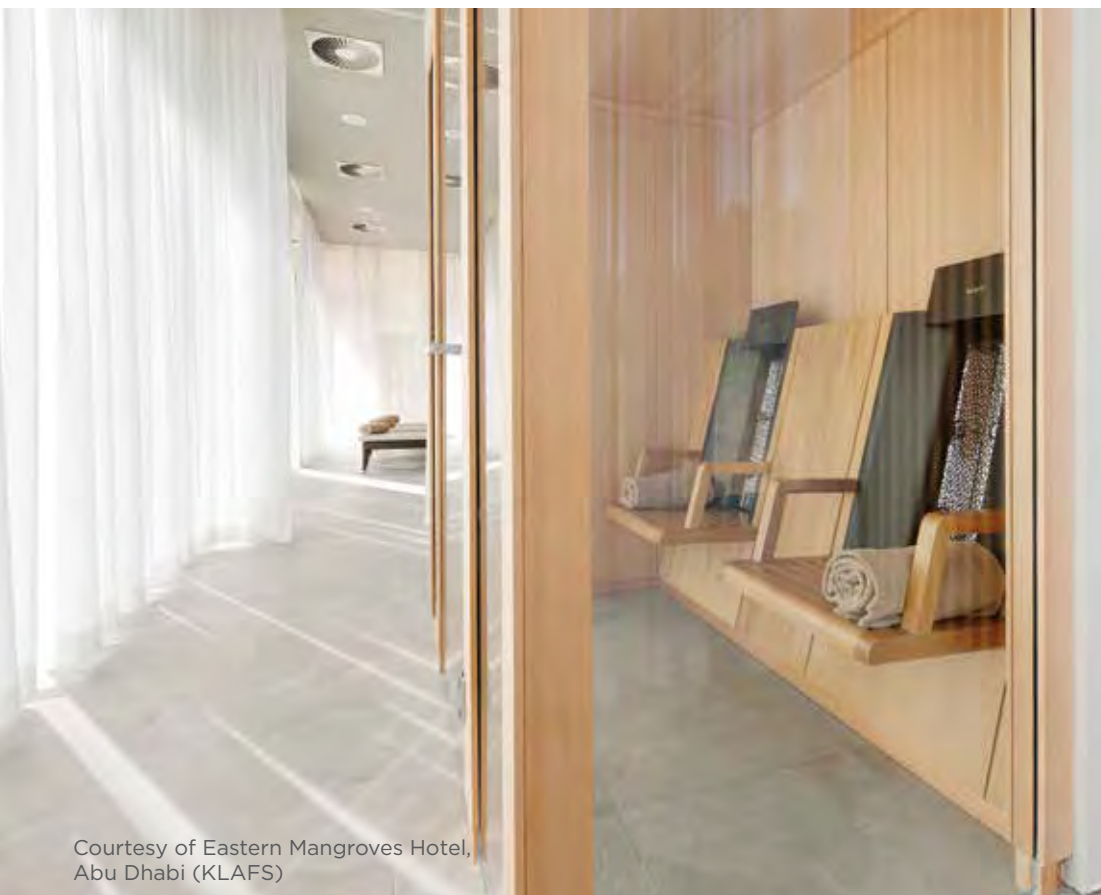

Courtesy of Eastern Mangroves Hotel, Abu Dhabi (KLAFS)

An infrared therapy room offers the therapeutic effects of heat without the high temperatures of a sauna.

Mud bathing has a long history and encourages relaxation and detoxification.



Courtesy of Sommerhuber

Mud Bath Rooms & Rituals

Mud bathing originated thousands of years ago as a medicinal and beautifying ritual—which minerals are inherent in the mud (or peloid), they can cleanse, exfoliate, absorb toxins, increase circulation and soften the skin. Though mud bath rituals that take place in private hamams or steam rooms are becoming more popular, the practice of immersing oneself or being wrapped in mud to soak up its positive effects is a long-standing practice.

Mud bath rituals typically take place in either a traditional steam room or hamam or in a specially designed “Rasul mud” area. Either a therapist applies the mud or bathers apply it to one another (this is a common couples treatment). After taking a shower, various types of mud is applied to different parts of the body. Then bathers enter a warm, herb-infused steam bath to encourage relaxation and detoxification. The mud needs to be kept moist so the correct degree of humidity must be maintained. After 20 minutes or so, an automatic “rain” system showers the room, starting the process of removing the mud. This is usually augmented by additional showering, followed by the application of moisturizer to the body.

Design Considerations: A specialized mud bathing room should incorporate showering facilities, steam and heating elements, relaxation benches/recliners and adequate drainage. The design will normally consist of two rooms: the actual mud bathing chamber and an ante room where guests can disrobe, shower post-treatment and, space permitting, receive the warm, oil-moisturizing massage to complete the experience. However, a spa operator who is interested in maximizing the return on investment for their steam room or hamam, could also easily use these cabins for mud rituals.

Inhalation Rooms

Although essential oils and aromatherapy are commonly present throughout a hydrothermal area, an inhalation room is designed specifically for inhaled aromatherapy to treat respiratory conditions. The goal of inhalation therapy (also called respiratory therapy) is to improve respiration and can be a specific treatment for chronic conditions such as asthma, bronchitis and emphysema.

Typically, an inhalation room will focus on steam inhalation combined with essential oils that target the upper respiratory tract, nose and sinuses. A variety of essential oils can be used (individually or combined); common choices are cedarwood, eucalyptus, pine, sandalwood, rosemary, tea tree and frankincense. The structure of the room will be similar to a steam room—medium-hot with a high humidity—with ergonomic benches, a low-volume steam generator, ventilation and an essential oil infuser or automatic dosing system, in which the essence of essential oils is infused into the flow of steam that enters the room.

Another option is oxygen therapy for increasing oxygen levels in the bloodstream. This is typically administered through a tube or mask at a specific inhalation station, or as part of an integral system built into a sauna, where guests can directly inhale oxygen via dedicated dispenser hoses.



Inhalation rooms combine steam with essential oils that target the upper respiratory tract, nose and sinuses using essential oils such as cedarwood, eucalyptus, pine, tea, sandalwood, rosemary, tree and frankincense.

Specialist Water Treatments

Water affects both body and spirit. After a busy day, it's instinctive to crave a warm bath, or, alternatively, cool water to invigorate or alleviate swelling. Thoughtfully constructed hydrothermal experiences can tap into a bather's emotions by bringing back the memories of standing in a summer rain or sitting underneath the gentle massage of a waterfall. The following includes some additional specialist water treatments to consider.

Floatation Tank

Float tanks and pods minimize external distractions and induce a state of deep relaxation through water that is made buoyant by a high concentration of Epsom salt. The bather not only experiences reduced sensory input, getting a break from the constant stimulation of day-to-day life, but also experiences a sensation akin to zero gravity with the water supporting them into a weightless state.

The temperature of the water in a float tank should be carefully calibrated to match skin temperature, effectively blurring the boundaries between the body and the water. As a result, the outside world fades away, enveloping users in a state of deep relaxation that is difficult to attain through other means. Bathers leave a float session rejuvenated and profoundly refreshed.

Design Considerations: Float rooms should ideally include a shower so users aren't forced to walk far with salt on their bodies. Not only is the salt corrosive to décor and other equipment, but it will be difficult to remove if it dries. It's best to choose non-slip vinyl flooring for this room as Epsom Salt can be very aggressive and has been known to penetrate tile grouting. Ideally, locate the filtration and pump in a separate plant room to minimize noise pollution. Avoid adding a toilet or vanity area to this room as

Open floatation tanks are a great addition to any spa or hydrothermal area, offering guests a unique experience that requires minimal staffing.



Courtesy of Floataway



Courtesy of Dornbracht International

A modern Vichy shower features a horizontal series of showerheads that form a “rain bar” over a waterproof, cushioned table. A therapist performs a manual massage while the water warms and hydrates the skin.

users can linger, preventing the next guest from starting their session on time. As with other rooms in this chapter, drainage and a hot water tap for cleaning is recommended. Underfloor heating is also a good idea. More information on Float Tanks/ Pools can be found in Chapters 2 and 6.

Vichy Shower

The term Vichy shower originates from the thermal spa of Vichy in France. Originally, a Vichy shower was a manual massage performed by two therapists while taking a shower. Now, the standard treatment is carried out by a therapist whose work is made easier by modern Vichy showers that allow for easy and quick adjustability of the showerheads.

The relaxing effect of the warm water on the muscles makes the body more receptive to the massage. The therapist gives a manual massage, and the water keeps the guest warm and hydrates the skin. Vichy treatments are often combined with other treatments, such as massages, using specific products and/or body wraps or other, classic wet table treatments. The main benefits of the shower itself are increased blood circulation caused by the flow of the water, hydration of the body to fight off fatigue and prevent acne, and the reduction of stress and toxins by stimulating the nerve response in the skin.

A modern Vichy shower is a horizontal series of showerheads that form a “rain bar” over a waterproof, cushioned table that features drainage on the side for the excess water. The showerheads should be easily adjustable even with wet or slippery hands, e.g. from massage oil or soap. Choosing a height-adjustable unit adds to ergonomic working conditions for the therapist and makes it easier for the customer to enter and exit the wet table. It’s highly recommended to choose a Vichy shower table with a shower arm that can be swiveled out of the way so that the room can also be used for other treatments.

Design Considerations: The Vichy shower and wet massage table is typically a permanent, bespoke piece of equipment that requires hot/cold water supply and drainage and adequate space for both the table and therapist—typically, a table will be 100 mm x 250 mm (3’ 3” x 8’ 2”) and will require a minimum of 800 mm (2’ 7”) of

working room around the sides of the table. The rainbar component is usually designed to swivel away from the table to allow for an unobstructed entry and exit on the table, in addition to creating space so that the room and table can be used for other treatments. A heated, wet table can add a further positive effect. Room temperature should be at least 27°C (80°F) and forced ventilation is required.

Hydrotherapy Tub

Hydrotherapy tubs are a central part of today's modern spa and wellness facilities. Modern units offer a sequential massage, starting with the feet and going towards the upper part of the body in small steps. In addition, the massage pressure can be regulated automatically so, for example, the intensity of the massage can be reduced in the beginning and at the end of the treatment.

Individual hydrotherapy tubs deliver a unique sensation of heat, buoyancy and hydro-massage. Often used without the aid of a therapist, the jets are positioned to stimulate and relax trigger points in the body. Aromatherapy oil can be added to the baths to intensify the bather's relaxation and engage the other senses; soothing skin products are also often featured. The natural healing power of mineral water or seawater can increase the effectiveness of the treatment. In addition, therapist-assisted treatments can be performed, which allow for the combination of both physical touch and hydro-massage. The mechanical impulse of the water nozzles provides an enhanced penetration of the massage into the body, accelerates tissue metabolism and enhances the reabsorption of metabolic waste products from the muscles which is important when treating sore muscles. As with all hydrotherapeutic applications, a key part of the underwater pressure-jet massage is the relaxation of the muscular system inside the warm water. This enables the massage jets to deeply penetrate the muscles. From a medical perspective, hydrotherapeutic massages can be prescribed for musculoskeletal circulatory disorders, skin diseases and disorders of certain internal organs.

Individual hydrotherapy tubs deliver a unique sensation of heat, buoyancy and hydro-massage.



To intensify the effects, salts, oils and other additives can be put into the water or thermal or mineral water can be used. If this is desired, the tub needs to be equipped accordingly to avoid any issues that can be caused by additives or aggressive water. In addition, a separate air bubble function can be installed to intensify the massage.

Design Considerations: Hydrotherapy tubs should be installed to allow space for therapist-assisted treatments. To achieve the most relaxing effect, choose a tub that emanates minimal noise and keep the room at 24°C (75°F).

Kneipp Therapy

Kneipp therapy was founded in the 19th century by Sebastian Kneipp, a Bavarian parish priest, who was ill with tuberculosis and developed this “water cure” as a way to heal himself. Kneipp therapy can be as simple as using hot and cold compresses interchangeably; however, Kneipp walks—in either real or manmade streams—are a great starting off point for Kneipp therapy. Kneipp walks use a mix of hot- and cold-water actions (stepping through the water) to stimulate blood circulation. Pebbles on the bottom of the stream/ walkway massage the feet, and alternating between the hot and cold baths stimulates circulation to all parts of the body.

Kneipp hoses are frequently found in hydrothermal areas, allowing bathers to access as required. Kneipp treatments are ideal for self-application either in a hydrothermal environment or even in a bather’s own home, where bathers can integrate the positive effects of Kneipp therapy into their daily routines.



Photos Courtesy of Dornbracht International

Kneipp leg effusion firms the skin, lowers blood pressure and encourages sleep.



Kneipp face effusion promotes blood flow and firms the skin. It can also offer a quick fix for a tension headache or migraine and to calm anxieties.

The relaxing effect of “floating,” makes these treatment beds uniquely suited for body wraps.



Courtesy of Unbescheiden GmbH

Specialist Beds/Tables

Dry Floatation Bed

Treatments on dry floatation beds are often carried out in combination with a body wrap. The bather lies on a membrane suspended within a tank filled with warm water that gives a sensation of weightlessness, while the thermic effect of the water enhances blood circulation and opens the pores of the skin, so that active components can more easily be absorbed by the body.

At the start of the treatment, the dry floatation bed is in a solid state to enable easy entry and application of the body wrap. Once applied, the air core is deflated and the guest sinks onto a heated water cushion, which results in the relaxing effect of “floating.” At the end of the treatment, the air core is inflated and solidifies again so as to better support the guest when leaving the unit.

Due to their stable lying surface, some units can also be used for manual massages. A multitude of different treatments can thus be performed inside one room using the same unit.

In addition to the relaxing effect of “floating,” the benefits of dry float will depend on the products being used. Cosmetic, dermatologic or therapeutic packs are applied. The warmth of the water supports the effect of the packs, making their absorption into the skin much easier. An additional benefit is the feeling of sinking into and lying in, or rather on, a surface of water.

Design Considerations: The room temperature should be kept at around 24°C (75°F) and the necessary equipment for the body wraps (e.g., the stirrer for the preparation of the media or the water for the warming and storing of body wraps) should either be in the same room or in a nearby central preparation unit. If the latter is the case, it’s important to ensure easy and quick access of the necessary equipment. A shower in the room or very nearby is vital for the guest to remove the media used during the body wrap.

Body Wraps

Body wraps are often paired with dry floatation treatments. Body wraps can be partial (treating only parts of the body) or full body.

Varying products and media are used in body wraps, and the benefits correlate directly to the components present in the media. Traditionally, wraps were predominantly mineral-based (sludge, mud, peat, moor) and, today, many treatments still use similar organic materials. In addition, wraps are now often complemented with cosmetic, dermatologic or other products.

A few examples of the wellbeing benefits:

- Detoxification (peloids and algae)
- Revitalization (cosmetic wraps, peloids, algae)
- Slimming (algae)
- Reduction of cellulite (algae)
- Moisturizing of the skin (cosmetic products)

Not only does the heat used in these treatments encourage the absorption of the media by the body, but it also helps promote relaxation, relieve stress and even work to increase blood circulation.

Body wraps are often applied on a standard therapeutic table, however, dry floatation systems can offer a better experience. The dry floatation bed will have a solid surface in the beginning, making it easier for the customer to lie down and enable the application of the body wrap. After, the guest sinks into a cushion of warm water and experiences a “floating” feeling. The warm temperature of the water supports the effect of the body wrap. When the treatment is coming to an end, the surface of the bed will become solid again, and the guest will be moved up, out of the water cushion, making it easier to exit the bed.



Courtesy of Unbescheiden GmbH

Dry hydrotherapy tubs allow bathers to experience the healing effects of water, heat and massage without disrobing.

Hot sand baths in today's spas are luxurious and often feature specialized quartz grains that store heat and provide a cradle-like environment for the body.



Courtesy of Gharieni Group

Dry Hydro Massage Bed

Dry hydrotherapy (or a dry water massage) allows a bather to experience the healing effects of water, heat and massage without ever getting wet. The benefits of hydrotherapy tubs are well documented, however there are drawbacks, including high operating costs, risk of injury (especially to the old or infirm) and, of course, cultural aversion to disrobing in public.

A dry hydro massage bed's water jets are located beneath a rubberized cover and provide the effect of a gentle hydro massage. The units are usually height-adjustable, allowing for ergonomic working conditions for a therapist and easier access for the guest.

Design Considerations: Dry hydro massage beds should be installed to allow space for any therapist-assisted treatments.

Hot Sand/Salt Beds

In a traditional sand bath (also referred to as psammo therapy for the Greek word for sand), bathers buried themselves in sand heated by the sun. The resulting warm, cocoon-like environment is described as surprisingly supportive and profoundly relaxing both physically and mentally.

Today, traditional sand baths are offered in warmer climates, such as Egypt, Morocco and the Middle East; while Japan has an extensive history of sand bathing, particularly where the sands are rich in certain minerals, and sand baths are often offered at sites where traditional onsen mineral baths are available.

Anyone can create a sand bath—simply dig a shallow hole in the sand and wait until the sun has warmed it, then recline face-up while someone buries you; once cocooned, enjoy the feeling of weightlessness and warmth for around 10 to 20 minutes. At a professional facility, there will be attendants on hand to make sure bathers are protected from any glaring sunshine while making sure they stay hydrated during the bath.

In a modern spa, sand or salt might be used interchangeably, depending on the guest's preference. Either way, these beds bring the bliss of the beach to guests wherever they may be in the world.



Courtesy of KLAFS

Residential/Private Spa Design

In contemporary home design, wellness has evolved from an afterthought into a fundamental element of luxurious living. Today's "luxury" is less about opulence and more about creating a sanctuary that fosters physical, mental, and emotional well-being. Top-tier amenities such as saunas, experience showers, relaxation loungers, cold plunge pools, ice baths and even snow rooms are making their way into the homes of those who value a wellness-oriented lifestyle.

An at-home wellness sanctuary can be as unique as the home it's situated in and the homeowners using it. It's important to homeowners that these features are not only beautiful but that they also elevate the existing design narrative within the home. This is possible due to the unprecedented array of interior and exterior finish choices and the quality level available for at-home wellness experiences.

At minimum, these areas will include a heated thermal area, such as a traditional Finnish sauna, a soft sauna, hybrid sauna or, if steam is the preference, a steam room or hammam-style room. To create a true hydrothermal journey, there should also be a cool-down option, such as an experience- or deluge-style shower system (these multipurpose showers make the most sense in a smaller area), and there should also be space dedicated to relaxation.

Ceramic loungers that relax users by enveloping them in gentle infrared heat from manufacturers like Sommerhuber are gaining in popularity, while a SWAY Sleep Lounger from KLAFS can double as a spa lounger and a sleep therapy bed, rocking users into a refreshing 20-minute power nap. Loungers will often come with built-in technology for music therapy, light therapy, and even massage features. Positioning these amenities in spaces with natural light and views or designing dedicated relaxation rooms contributes to a restorative ambiance.

Design Considerations

Whether it's a home or a luxury hotel suite, smaller spa spaces should, ideally, be designed to the same specifications as larger, commercial spas—simply on a smaller scale. Limited space means that the amenities included in a smaller spa will be a personal decision, however, typically, there will be a steam room or sauna or a combination of both and perhaps a hot tub and some form of cooling experience such as a specialist or multi-feature shower.

The biggest consideration here is space, so clever planning is needed. Combined solutions, like a steam shower that also serves as a steam room and includes effects like sound, fragrances and light, can be a great choice for smaller spaces. And, if possible, a separate relaxation area should be included to get the full benefits of the hydrothermal therapies.

Space limitations make professional planning even more important. For example, it's important to ensure there is sufficient access to all equipment and components for maintenance purposes, something that is often overlooked when wet areas are not designed by specialists. Of course, the building components, including electrical devices, should be smaller than those featured in a commercial build, but it's important to seek out quality and reliability that's on par with solutions found in a commercial spa so the wet area, this will ensure that it will stand the test of time, keeping lifetime maintenance costs to a minimum. A knowledgeable spa designer will look for prefabricated modular components to build a small steam room, for example. Fitting reliable, high-grade electrical devices with the advanced functions found in commercial spas also makes sense—just as you might choose the home version of the Italian espresso machine found at your local café or coffee house.

Automation is another big area of consideration for a residential spa. Technical standards are constantly evolving but being able to operate your spa via an app on a smartphone or other device will make a residential spa experience much better and in sync with current trends in home automation. To learn more about creating a connected, smart spa, see Chapter 8.

Private Hydrothermal Areas: Design Concepts

Designing hydrothermal areas for private use requires clever planning due to limited space. Here, and on the following page, are two different concepts—both are open-planned designs, including glass fronts for the sauna steam rooms. In addition, because it's an intimate living environment, the rooms also include more space for lying down versus sitting—so the benches are wider where possible; and, to maintain proper hygiene, large surface tiles are used. Both private hydrothermal spa areas are approximately 30 square meters (or 320 square feet). *The following examples are courtesy of Sommerhuber.*



Private Spa Design Concept A

Includes a heated relaxation lounge and steam room with heat-storing ceramic benches.

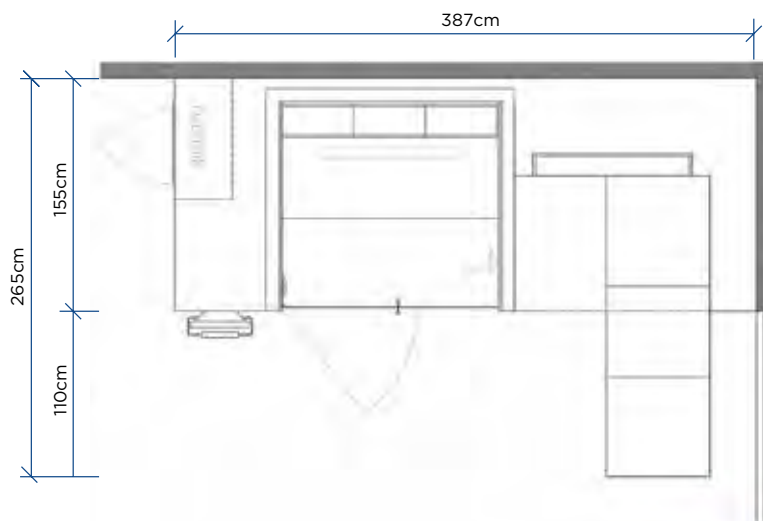

**Private Spa Design
Concept B**

Includes heated relaxation loungers; steam room with heat-storing ceramic benches; and a hydrothermal tub.

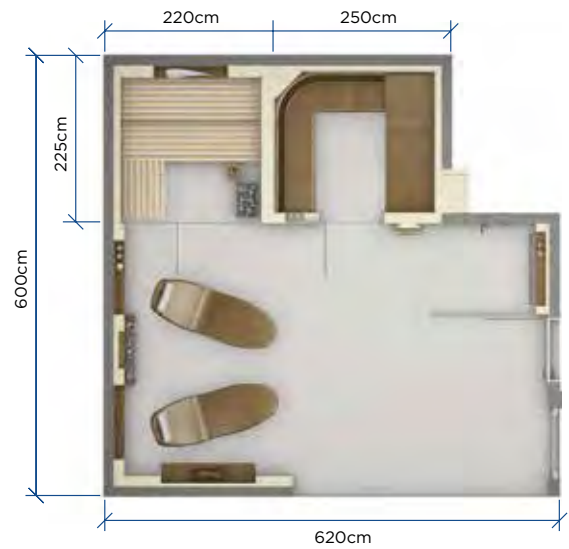
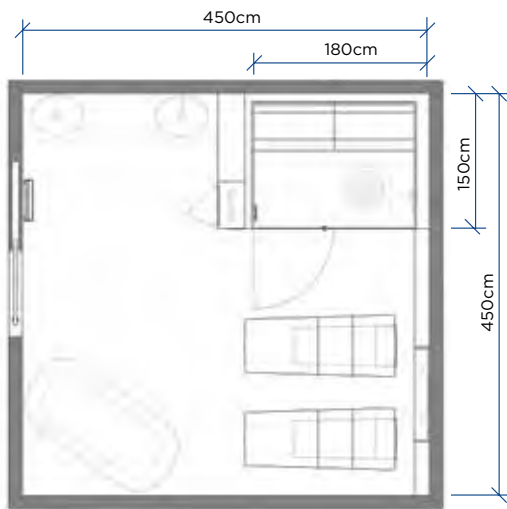

**Private Spa Design
Concept C**

Includes heated relaxation loungers; traditional sauna; steam room with an ergonomically shaped heat storing ceramic bench and floating lounger; walk in experience shower.



Chapter Six

Pool Areas: Function and Design

The benefits of having a pool or pools—whether full-size lap/exercise pools or vitality pools—in a spa are numerous. “Hydrotherapy” is a term often used to describe the use of water therapy for relaxation, pain relief and treatment. Specially designed pools are a great way to take advantage of the physical properties of water, including temperature and pressure, to promote relaxation and healing of the body.

Hydrotherapy offers a wide array of health benefits, whether combining soothing water temperature with jets and other features for self-massage; using a shock of cold water to stimulate blood circulation; or using the advantage of water for low-impact exercise—the weightlessness of a person’s body in water means swimming offers the only way to exercise without a harsh impact on the skeletal system.

This chapter looks closely at how pools work and introduces the reader to the construction and design considerations to be made when adding a pool to a spa or home.

Pools play a key role in hydrotherapy, promoting relaxation and stress relief.

Common Spa Pools

Pool Type	Health & Wellness Benefits	Temp	Depth	Minimum Water Turnover Rate
Lap/Exercise	<ul style="list-style-type: none"> • Exercise & fitness • Water aerobics 	27°C to 29°C 80.6°F to 84°F	1.0 m to 1.2 m 3' 1/4" to 4'	4 hours
Hydrotherapy/ Vitality	<ul style="list-style-type: none"> • Massage and relaxation • Increase muscular power • Increase range of joint movement 	34°C to 40°C 93°F to 104°F	1.0 m to 1.2 m 3' 1/4" to 4'	0.5 to 1.5 hours
Onsen	<ul style="list-style-type: none"> • Relaxes muscles • Improves mobility 	34°C to 40°C 93°F to 104°F	1.0 m to 1.2 m 3' 1/4" to 4'	0.5 to 1.5 hours
Cold Plunge	<ul style="list-style-type: none"> • Stimulates circulation 	5°C to 10°C 41°F to 50°F	1.5 m 4' 11"	20 to 30 minutes
Floataion	<ul style="list-style-type: none"> • Pain and stress relief 	35°C to 36°C 96.8°F	1.0 m to 1.2 m 3' 1/4" to 4'	0.5 to 1.5 hours
Watsu	<ul style="list-style-type: none"> • Relaxes muscles • Improves mobility 	34°C to 40°C 93°F to 104°F	1.0 m to 1.2 m 3' 1/4" to 4' 11"	0.5 to 1.5 hours
Saltwater/ Mineral	<ul style="list-style-type: none"> • Stress relief • Provides energy to the body • Calms the nervous system • Eliminates/reduces skin irritation • Moisture to the skin 	32°C to 36°C 89°F to 96.8°F	1.0 m to 1.2 m 3' 1/4" to 4' 11"	30 to 90 minutes
Kneipp Walk	<ul style="list-style-type: none"> • Stimulates circulation • Stress relief • Helps relieve joints 	Cold: 15°C to 20°C 59°F to 68°F Hot: 30°C to 35°C 86°F to 95°F	200 mm to 600 mm 8" to 23 1/2"	0.5 to 1.5 hours

*Temperatures may vary depending on geographical location and if pool is indoor or outdoor.



Courtesy of Barr + Wray Ltd.

Lap/Exercise Pool

Temperature

27°C to 29°C
80.6°F to 84°F

Depth

1.0 m to 1.2 m
3' 1/4" to 4'

A pool that is large enough to exercise in offers significant benefits. The size of the pool will be determined by the space available and the types of exercising required—for example, different specifications are required for resistance training versus swimming lengths/laps. As a guide, an exercise pool that can accommodate 10 people should be approximately 20 m x 6.5 m x 1.2 m (65' 7" x 21' 4" x 3' 11") deep, while a traditional lap pool is 25 m long x 12.5 m wide (82' long x 41' deep). Where space constraints exist, the use of counter current/swim jets allow on-the-spot exercise.

Benefits

As mentioned previously, swimming is the lowest-impact aerobic exercise available. When the human body is submerged in water, it automatically becomes lighter. In fact, when immersed to the waist, the body bears just 50% of its weight; when immersed to the chest, it reduces to approximately 25% to 35%; when immersed all the way to the neck, the body bears only 10% of its own weight. This type of weightlessness is unattainable any other way.

This means that exercising in a pool is ideal for working stiff muscles and sore joints. The Arthritis Foundation suggests the ideal exercise for relief is one that stretches and strengthens muscles while delivering an aerobic workout—such as doing laps in the pool.



Courtesy of Barr + Wray Ltd.

Hydrotherapy/Vitality Pool

Temperature

34°C to 40°C
93°F to 104°F

Depth

1.0 m to 1.2 m
3' 1/4" to 4'

The combination of warm water (average temperature 38°C or 100°F) and a selection of water features, including air tubs, swan-neck fountains, air loungers and water jets, means hydrotherapy/vitality pools provide unique benefits, including the cleansing and detoxification of the skin, relieving tired and aching muscles, increasing circulation and relaxing the mind and body.

The difference between the two pools is that hydrotherapy pools are typically much larger than vitality pools and allow guests the ability to “walk” or “float” a course of water features; a vitality pool is more akin to what is often called a “Jacuzzi” (the brand name that has become synonymous with pools with water jets). Vitality pools offer a mini-hydrotherapy experience and are typically used where space will not permit the inclusion of a full-size hydrotherapy pool.

Benefits

These pools deliver true *external* hydrotherapy—the complete immersion of the body in hot water, serving to relax muscles.



Vitality pool features, like swan-neck fountain (top); air recliners (middle) and air tubs (bottom), increase relaxation and stress relief. (Photos courtesy of Barr + Wray Ltd.)



Onsen Pool

Temperature

34°C to 40°C
93°F to 104°F

Depth

1.0 m to 1.2 m
3' 1/4" to 4'

This pool originates from Japan—and plays a big role in the country's ritual bathing practices. “*Onsen*” actually translates as “hot springs” in Japanese, but has come to refer to the natural spring baths found throughout Japan.

Traditionally, onsens were used outdoor. They are most often made from Japanese cypress, marble or granite, while indoor tubs are typically constructed of tile, acrylic glass or stainless steel.

Benefits

Since *onsens* use natural hot springs, their benefits are closely dependent on the mineral properties and content of the water itself. But typical benefits include the easing of neuralgia, alleviation of muscle pain and the reduction of the symptoms of chronic skin disease. Onsen bathing is also believed to relieve chronic fatigue and stress.



Courtesy of Aurelio Hotel & Chalet Lech

Cold Plunge Pool

Temperature

5°C to 10°C
41°F to 50°F

Depth

1.5 m
4' 11"

A cold plunge pool is typically entered after and between hot thermal treatments to cool bathers down.

Going from a heated environment to a cold plunge, which is usually kept at about 5°C to 10°C (41°F to 50°F), stimulates the body in several ways. A quick, 30-second dip is enough to kick start circulation and dilate the vascular system, delivering the positive therapeutic effects of hot/cold contrast therapy.

Benefits

First, the cold water numbs the nerves around joints and muscles. It also causes the release of endorphins and hormones with analgesic properties. Not only does this alleviate some joint pain but muscle aches as well. The cold-water plunge is also believed to stimulate the immune system.



Floatation Pool

Temperature
35°C to 36°C 96.8°F
Depth
1.0 m to 1.2 m 3' 1/4" to 4'

A floatation pool or tank is usually enclosed and typically measures approximately 2.5 m long x 1.2 m wide (8' 2" x 4"). The water in the tank is kept at body temperature. The most important element of the tank is the addition of magnesium sulfate (Epsom salt) that is dissolved in the tank: approximately 400 kg of Epsom salt to 200 gallons of water—this is what creates the weightless “float.” As opposed to a swimming pool where there is a sense of weightlessness, gravity in a floatation tank is completely nullified by the buoyancy caused by the dissolved Epsom salt.

Unique to the enclosed floatation tanks is the sensory deprivation they provide. This restricted stimulation has been proven to change the way the brain works, showing an increase in theta waves in the brain¹—the waves that are activated by meditation and active during REM sleep.

Benefits

The increase in theta waves is thought to reduce stress and encourage a happy, contented brain. The physical benefits of floating in magnesium sulfate also gives those that suffer from joint and/or muscle pain huge relief by taking away the effects of gravity on the body. There is also the innate benefit of absorbing the Epsom salt through the skin, which is full of magnesium, something many people are deficient in. Raising magnesium levels can improve circulation, ease muscle pain and relieve stress².



Watsu® Pool

Temperature

34°C to 40°C
(93°F to 104°F)

Depth

1.0 m to 1.2 m
3' 1/4" to 4'

These are pools designed specifically for Watsu massage, a gentle form of body therapy performed in warm water. It combines elements of massage, joint mobilization, shiatsu, muscle stretching and dance. The receiver is continuously supported while being floated, cradled, rocked and stretched. This typically requires a 3.5-meter (11' 6") diameter pool for single treatments, and a larger pool if the desire is to give simultaneous treatments.

Benefits

Watsu massage is designed to induce a state of deep relaxation to the body and the mind and relieve stress. Because it's such a gentle treatment, it's also good for the elderly and children. The weightlessness effect of the water provides for gentle stretching and joint mobilization. This treatment is often used to treat different conditions like brain injury, stroke, spinal cord injury, Parkinson's disease, cerebral palsy, arthritis and fibromyalgia. It is also used to treat chronic pain and in post-surgical or post-trauma recoveries.



Courtesy of Peninsula Hot Springs, Australia

Mineral Pool

Temperature

32°C to 36°C
(89°F to 96.8°F)

Depth

1.0 m to 1.2 m
3' 1/4" to 4'

Mineral pools come in all shapes and sizes—they can be full size pools, wading pools or vitality pools. The water temperature of mineral baths may be hot, warm, cool or even cold. Mineral waters can have an acidic, basic or neutral pH, depending on the types of dissolved solids in the water. Some mineral waters contain arsenic or other toxic substances and should never be used for drinking water, unless specified that it is all right to do so.

Benefits

Throughout the centuries, mineral spas and pools have been enjoyed on many levels, including for cleansing, social and health benefits. Today, the healing benefits of the natural mineral springs—referred to as balneotherapy—are well-known and usage of hot springs is on the rise.

For an in-depth overview of hot springs and differing types of mineral waters, see Chapter 7.



Kneipp Walk

Temperature

Cold: 15°C to 20°C
59°F to 68°F

Hot: 30°C to 35°C
86°F to 95°F

Depth

200 mm to 600 mm
8" to 23 1/2"

History

Kneipp therapy was created in the 19th century by Sebastian Kneipp, a Bavarian parish priest, who fell ill with tuberculosis and strongly believed that his use of a “water cure” healed him.

The Kneipp walk is a water treatment using a mix of hot and cold water actions (stepping through the water) to stimulate the metabolism of tissues and the circulation of blood. Pebbles on the bottom of the stream/walkway massage the feet, and the alternation of hot and cold baths stimulate circulation of all parts of the body.

There are two walks used—the bather begins by stepping in hot water for one minute to two minutes (the water is usually lit up with color), and then moves to the cold-water pool (usually lit light blue) for half a minute. The process is repeated approximately three times. A handrail is often used to help the bather walk through the different water pressures. Kneipp walks can be located anywhere within the spa journey and are often used as a feature by designers, creating interesting paths and walkways.

Benefits

Kneipp therapy is well-respected and even subsidized by the government in some European countries for both preventative and rehabilitative purposes. Kneipp therapy does not have to take place in a pool—hot and cold compresses can be used—but pools are most common.

Applications of hot and cold water have long been used to cure headaches, improve lymphatic function and even eliminate hangovers. Kneipp walks are often used in treatment for conditions from arthritis, abscesses and heart disease to asthma, diabetes and allergic eczema.



Courtesy of Center Parcs UK

A well-designed pool is an aesthetically-pleasing focal point.

Pool Area Design

When designing pool areas, it is important to remember that people interact differently when minimally clothed. This means there is an increased need for personal space.

Special consideration should be given to corridors, passageways and circulation spaces where guests travel in opposite directions. Pinch-points should be avoided, and poolside relaxation spaces should be designed with personal space in mind. If there is food or beverage service offered in these areas, than space for staff to attend to guests and tables for service items should be provided.

In addition, benches and seats in the pools need to allow for adequate space between bodies (600 mm or 23" is recommended); where possible, it's advised to provide individual seating so that bathers don't have to consider invading another's personal space on a communal bench. Seats should also be shaped to allow for comfort and space where air jets might push the bather away from the seat back.

To create a bather-friendly environment, pools should also have sufficiently wide treads and short risers for entries and exits and no sudden drops at the junction with the floor.

Surface Finishes

Surface finishes for pools should be selected based upon several criteria: safety, hygiene, ease of maintenance and visual appearance. Natural stone is a popular finish in pool areas; however, these don't carry slip-resistance ratings like manufactured tile finishes. Natural finishes, such as slate, should be carefully selected, as many varieties have a tendency to de-laminate, and any marble finishes with fissures should be avoided. Limestone, in all its various forms, should generally be avoided in wet areas, as it is not only very soft and easily eroded, but species like Travertine can be very heavily fissured. Even though these tiles can be supplied with fissures filled with a resin-based material, new openings will inevitably form during use.

If choosing natural stone, it's important to use a testing agency to test slippage. The cost for this is minimal and is highly recommended, as it demonstrates due diligence. Of course, it's also imperative to choose floor surfaces that minimize the potential for slippage and use the correct sloping angle³ for proper drainage. It's worth noting that the requirement for non-slip surfaces is only in critical areas, including the treads of the steps and the top of the slope inside the pool down to the deeper areas.

Pool Types

The aesthetics of a pool are very much affected by the type of pool chosen. There are two types of pools: overflow and freeboard. An overflow pool is most commonly chosen for hydrotherapy spas because they can be level with the decking or designed as infinity pools. On the other hand, in a freeboard/skimmer pool, the water level is approximately 150 mm (6") below the pool deck, creating a visible edge.

Not only do the pools look very different, but they also function differently in terms of how they handle the treatment and flow of pool water. An overflow pool uses a balance tank to store and treat the overflow of surface water that runs off when people get into the pool. The displaced water is captured, treated and then pumped back into the pool. A skimmer pool, instead, does not have the inherent benefit of constantly renewing its surface water because the displacement is handled by the water level rising versus vacating the pool.

This means overflow pools are very efficient when it comes to removing and treating polluted surface water. This is important because surface water, which holds approximately 75% of a pool's pollution, is often ingested by swimmers.



Common Mistakes in Pool Builds

- Chemical smells permeating nearby areas
- Floor slippery and dangerous
- Bulbs in the pool difficult to replace
- Poor overflow drainage
- Inadequate filtration and water treatment plant space
- Insufficient provision of MEP services—power, water, drainage etc.
- Inadequate water turnover rates leading to poor water quality
- Adopting high filtration rates leading to poor water quality
- Lack of secondary disinfection (e.g. UV) leading to excessive chemicals in the pool
- Poor provision for the delivery of chemicals to the plant room
- Inadequate filtration and poor chemical balance causing poor water quality
- Failing to backflush filters on a regular basis—once a week minimum or when the indicated by inlet and outlet pressure gauges

Design Considerations

Pools are complex to build and manage. User safety, efficient water treatment and pleasing aesthetics start with careful planning, specification and design.

The water treatment system must be an integral part of the architectural, structural, mechanical and electrical design of the building. It is critical at the earliest stages of a project, after determining the type of pool(s) being installed, to consider the following key factors:

- Anticipated bather load (required to determine pool and plant sizing)
- Pool size and volume (length x width x depth), plus any hydrotherapy equipment to be incorporated into the pool
- Pool location
- Balance tank location
- Plant room location and size
- Level of pool, balance tank and plant room are of paramount importance

Pool Tank/Basin Construction

Pool tanks or basins (the pool structure itself) can be built from various materials, including concrete, stainless steel or fiberglass. There are some functional and aesthetic differences between these materials.

Concrete: A common, affordable choice, but pools rendered in concrete can suffer from water leakage. It's important to conduct a percolation test to ensure water integrity before tiling a pool built from concrete.

Stainless Steel: Popular for both its aesthetic value and water retention ability. A minimum grade 316L stainless steel, which is more resistant to corrosion than

Access for Persons with Disabilities

- The route to the pool must not be confusing and lead directly through a shower area.
- Handrails should be provided between the changing rooms and poolside, and tactile information must be placed at critical points on circulation routes.
- Design and detailing at the pool edge is critical to warn swimmers they are approaching the pool edge.
- The minimum water depth to provide sufficient buoyancy for adult disabled swimmers is 1,200 mm (4'). However, learner pools should be accessible to disabled children and other groups who may prefer a shallower depth of water.
- Moveable floors can be particularly useful in learner pools, as they provide the deeper water necessary for adult swimmers with a lower-limb disability.
- Disabled swimmers can access the pool by a variety of means with a ramped entry or hoist being the minimum requirement.
- Floor finishes must be reliable and slip-resistant with a non-abrasive surface.

See Chapter 9 for more details on pool access for persons with disabilities.

A hydrotherapy pool is often the center of a spa, offering a relaxing place to gather and continue to enjoy the benefits of communal thermal bathing.



Courtesy of Barr + Wray Ltd.

conventional stainless steel, should be used for freshwater pools. If the pool is saltwater, a higher grade of stainless steel is required. Modular stainless steel is also an option. Here, the stainless steel panels have a PVC lining. The modular design makes them quick to construct and removes the need for hot welding on site.

Fiberglass or Glass Reinforced Plastic: Offer great water retention and can be delivered as a single piece or in sections for construction on site.

Pre-Formed, Composite Shell: A next-generation pool structure. Pre-formed, composite shells combine three materials working together to create a bespoke, tiled pool that is quick and easy to install. Pool shells are manufactured out of fiberglass with an epoxy-laminate layer to ensure waterproofing and finished in a ceramic mosaic tile; finally, the fully finished pool is delivered directly to the site, ready for installation.

Pool Finishes

Pools are usually finished in tiles, either mosaic or larger format. And non-slip tiles are essential around stairs and shallow areas. Natural stone or slate is not recommended because it is porous and can discolor, leaving a residue on the pool floor. If considering such materials, test them with pool chemicals prior to installation.

In order to increase waterproofing, a rendered finish can be used. The rendered finish is applied between the concrete structure and the finish tile.

Stainless steel pools are usually left bare (versus tiled) and can be polished to produce either a satin-brushed or mirror finish.

PVC liners are often used in large, public pools where there's a need for an affordable pool finish that is watertight. These flexible membranes can be applied to both concrete and stainless steel pools. They come in various colors.

Pool Lighting

Halogen*

Currently being phased out in most countries because they are less energy efficient.

LED*

Offer longer life and varying color options; various size and styles of fitting available (flush, beveled, frosted glass, strip lighting, stainless steel bezel, etc.).

Fiber Optics

Provides lower level of illumination but offer unrivalled effects. Can create moods and sensations that cannot be achieved with most other lighting systems. Because fiber-optic lights contain no heat or electricity, they are well-suited for use in pools. They are also easier to maintain, as there is no “bulb” to replace; instead an illuminator or projector transmits the light through the fiber. This “remote light projector” can be located conveniently for bulb replacement.

*Halogen and LED lights must have an IP68 rating—this is the highest Ingress Protection rating and means they are protected against complete, continuous submersion in water.

Indoor pool at Tschuggen Grand Hotel, Arosa, Switzerland.



Pollution and Cleaning

Pollution in swimming pools' water comes from many sources; however, swimmers themselves are the major source. In fact, it is said that each swimmer can introduce as much as 600 million bacteria into the pool! In addition to bacteria, there are other pollutants caused by swimmers, like perspiration, cosmetics, suntan lotion, hair products, sweat, urine, etc.

Interestingly, the chemicals used to treat pool water can also create their own problems. A key mistake in water treatment is when an operator uses five or six chemicals to keep the water in balance. These can include: hydrochloric acid (for pH correction), sodium bicarbonate (for alkalinity adjustment), alum (as a filter aid), calcium flake (for grout protection) and sodium thiosulphate (used for over chlorination). Scum line cleaners and poolside cleaners can also find their way into the pool.

With careful management and selection of the correct sanitizer, as few as two or three chemicals can do the same job with better results.

How Pools Operate

When considering the installation of a pool, it's important to understand how they work, especially in regards to filtration and water treatment.

All the pool water must be filtered and treated to keep the pool safe and clean—and determining how long it takes to move the entire contents of a pool through the filter system is called “turnover rate.” The turnover rate required helps determine the pool pump that is needed. A higher-use pool with more water will require more frequent turnover.

Guide to Pool Pollution

Surface Pollution: Hair, dust, grease, excreta, floating debris, grass, etc. This can often be handled by an efficient surface draw-off system, such as those found in level-deck pools. Of course, larger items of surface debris can be removed by the pool staff.

Dissolved Pollution: Urine, perspiration, cosmetics, etc. Efficient filtration and circulation is critical for treatment, as well as maintaining sufficient chlorine levels for breaking it down.

Suspended-Matter Pollution: Water treatment and cleaning chemicals. To deal with these, use the minimum quantities of chemicals in and around the pool and maintain carefully balanced water.

Insoluble Pollution: Fluff, dirt, precipitated chemicals, filter sand, etc. Sweep or vacuum the pool bottom daily or as required.





Overflow: Level Deck

Pool water is level with the pool surroundings. Aesthetically pleasing and inherently cleaner because most of the polluted surface water flows over the edge of the pool into the transfer channel connected to the balance tank.

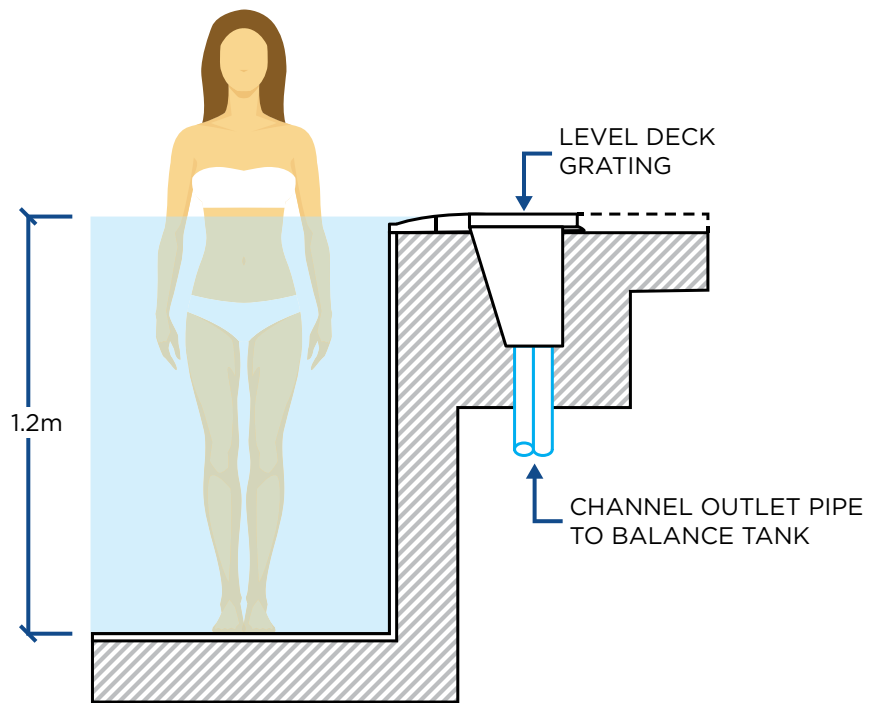



Overflow: Infinity Edge

Similar to level-deck pool, but the water is transferred to an overhanging channel and gives the visual appearance of the pool water blending (merging) with the horizon.

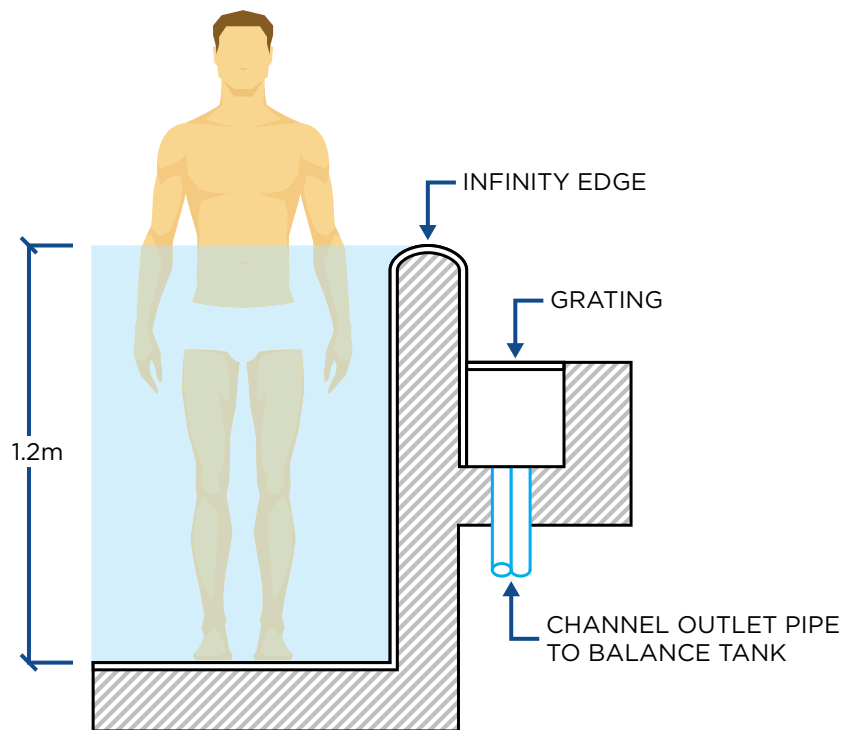



Freeboard: Skimmer

Space between the water level and the top of the pool deck.

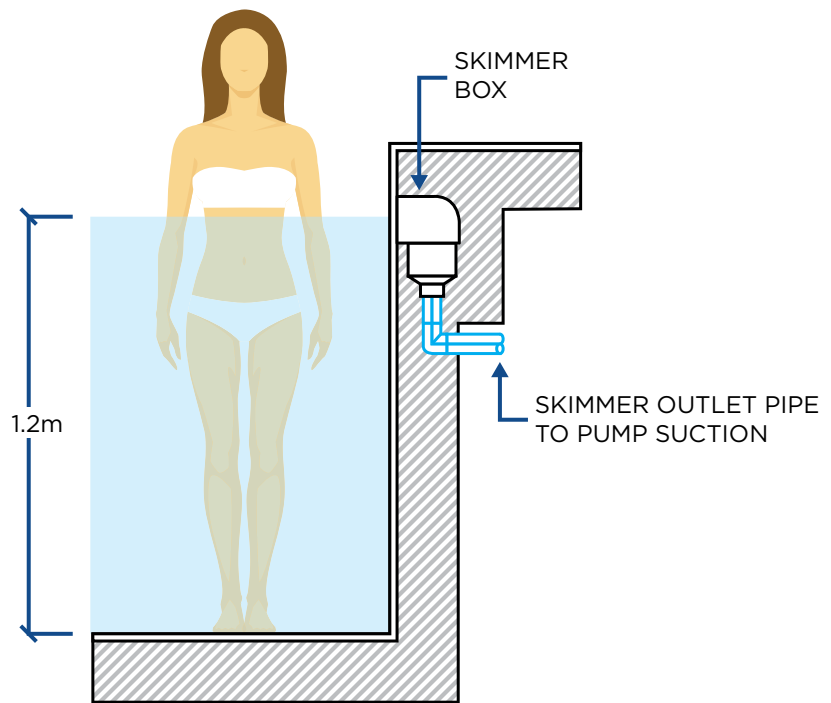

Pool Water Safety

Pool staff should be trained to conduct regular testing of the pool water. Below are testing guidelines:

Daily Tests (Every 2-3 Hours)	Water Quality Values
Free Chlorine	Range 0.5 to 3.0 mg/l (Aim for 1.0 to 2.0 mg/l)
Combined Chlorine	Not more than one third of total chlorine
pH	Range 7.2 to max. 7.6 (Aim for 7.2 to 7.4)
Weekly Tests	Water Quality Values
Alkalinity	100 ppm to 180 ppm Sodium Hypochlorite 100 ppm to 120 ppm Calcium Hypochlorite
Calcium Hardness	200 ppm to 1000 ppm (not less than 200 ppm)
TDS	Total Dissolved Solids Max. 1000 ppm above source water
Pool Balance	Refer to Langelier Saturation Index

Pool Chemical Room Safety

Careful consideration has to be given for safe delivery of chemicals, including offloading and transfer within the building, avoiding stairs where possible.

Storage: Adequate, separate storage and containment space must be provided for the chemical containers and bags required for the normal daily and weekly refilling of the operational chemical day tanks.

Containment Bunds: A chemical bund area should be constructed in concrete with a cement render internally and finished with a chemical-resistant (or fiberglass-lined) material, providing a fully contained bund capable of holding 110% of the maximum chemical volume.

Segregation: Separate enclosures should be maintained for all potentially hazardous chemicals (acids and alkalis) in separately ventilated rooms, with a minimum of four air changes per hour.

Drench Showers/Eyewashes: Emergency drench showers/eyewashes are recommended in commercial chemical rooms.

Eyewash: A sealed sterile type of eyewash bottle should be located near the intake point and in the chemical stores

Sink: A large sink with hot and cold running water is required for cleaning the chemical injectors.

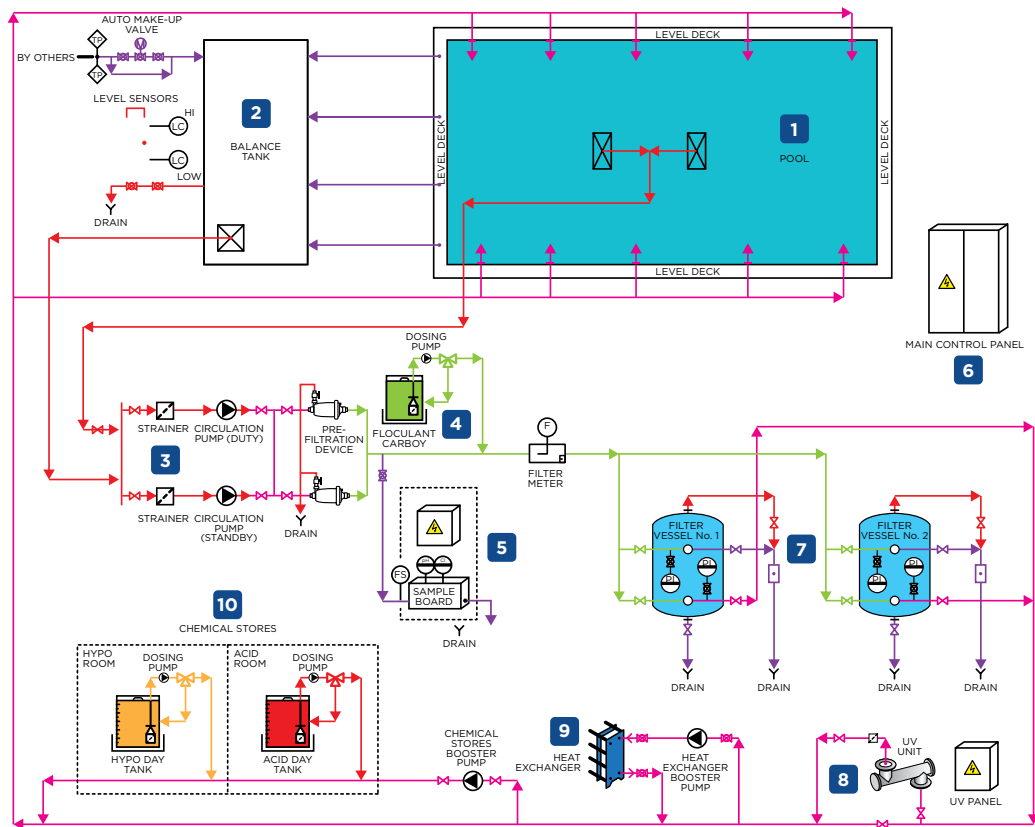

Filtration Water Treatment Flow

1: Pool Tank/Basin

The pool illustrated here is a typical level-deck pool with concentric bottom-sump outlets and wall inlets evenly positioned to provide the best possible water distribution. It is recommended that outlets have a maximum velocity of 0.5 m/second for suction and 0.5 m to 1.0 m/second for inlets. All pool fittings should be designed in compliance with international pool entrapment standards, which means no gap greater than 8 mm. In larger pools, it's recommended to include vacuum points for pool cleaning so automatic pool cleaners can clean the pool overnight.

2: Balance Tank

Balance tanks are required for all overflow pools in order to contain the "surge" caused by bather displacement, whether level deck, infinity edge or other variation. Bathers entering the pool displace water to the overflow system, which feeds pool water to the balance tank. This effectively drops the pool water level.

Fresh water is introduced into the system via an auto make-up system in the balance tank and the pool inlets return the height of the pool water to normal.

3: Circulating Pumps

Main circulating pumps are at the heart of the filtration system, and their selection is crucial to the continuous operation of the filtration and water treatment system. Upstream of the main circulation pumps, strainers and pre-filtration devices fitted with drains, should be installed to protect the pumps from any pool debris. (These should be inspected and cleaned on a weekly basis.)

4: Flocculation Dosing System

Incorporating the continuous dosing of a coagulant in very small quantities is an effective way to remove microscopic impurities and organisms from a pool, including common waterborne parasites, like cryptosporidium, the germ that causes diarrhea.

5: Chemical Controller

Monitors and regulates pool chemical levels.

6: Electrical Control Panel

Electrical control panels are required to provide power to all of the electrical equipment in the plant room and to provide overload protection to the equipment. The electrical control panel can also be linked to the Building Management System, providing fault signals to a central control room.

7: Filtration

Good filtration is essential for ensuring water quality. The most common filtration method for commercial usage is medium-rate, vertical sand filters, but there is also regenerative, diatomaceous earth and cartilage filtration to consider. Of critical importance is the filtration rate—the higher the rate, the lower the filtration efficiency. *Note: Filtration rates should not exceed 25m³/m²/hour (flow rate/area of flow rate/time).*

8: Secondary Disinfection

It is strongly recommended to have a secondary disinfection process in place to fight waterborne parasites. There are several options available:

- **Full Ozone:** Ozone gas is used to complement chlorination and results in lower levels of chlorine; however this requires a good level of expertise to operate, additional space in the plant room and is more expensive to install and run.
- **Ultra-violet (UV):** Commonly used to complement chlorination and allows pools to operate with lower levels of chlorine.
- **Partial-Flow UV or Ozone:** an alternative when there are space restrictions as only a 10% to 25% of total flow rate is treated so not as effective as full-flow treatments.

9: Pool Heating

Common methods of heating are gas and/or oil boilers; electrical heating; heat exchanger (particularly used in very hot countries).

10: Chemical Injection

Automatic chemical dosing systems are recommended where possible.

Pool Chemical Primer

Disinfectants

- Sodium Hypochlorite: Supplied in liquid form either in small pack or bulk with a maximum chlorine strength of 15%. Widely used in pools where hard water is the source water.
- Calcium Hypochlorite: Supplied in granular and tablet form with a maximum chlorine strength of 65% to 68%. Most often used in pools where soft water is the source water.
- Bromine: Supplied in granular or tablet form, bromine is an alternative to chlorine. Though closely related, bromine is able to withstand heat better than chlorine so is recommended for spa pools, but isn't ideal for larger commercial pools.

pH Correction

- Sodium Bisulphate: Supplied as a dry powder to be mixed in water.
- Hydrochloric Acid: Supplied in concentrated liquid form, requires dilution and is very gaseous.
- Sulphuric Acid: Supplied in concentrated liquid form, requires dilution. An exothermic reaction occurs when added to water.
- CO₂ Gas: Supplied in either small pack container or bulk, this product is not advisable to be used within a pool that has air features, as the gas will escape into the atmosphere while the water is agitated, reducing the effectiveness of the CO₂ gas and making the control of the PH difficult to manage.

Alternative Disinfection Treatments

- Frequently new water treatment processes enter the market with bold claims of providing chlorine-free disinfection or chemical-free disinfection. In certain circumstances some of these treatment processes may bear further consideration, but always obtain independent professional advice before using and don't simply rely on the marketing claims provided by any one supplier.

Plant Room Design

Plant rooms need to be considered in the very early stages of the design process. There are numerous reasons for this—including the fact that they will invariably take up more space than operators might anticipate. They also require input from a structural engineer to ensure that the foundation is capable of holding the weight of the balance tank and filtration and water treatment plant. And, finally, plant rooms must be situated in areas that allow for the minimizing of noise and vibration.

Plant Room Design Considerations

Foundation: A structural engineer should ensure that plant room slab is capable of holding the working weight of the balance tank and filtration and water treatment plant.

Noise Reduction: Plant rooms should be strategically located to keep noise to a minimum in other areas of the spa. In addition, every effort should be made to minimize noise and vibration. For example, typical equipment noise levels for main circulating pumps are >80dbA, and air blowers are >85dbA. Insulated acoustic panels and/or doors should be incorporated.

Drainage: Gullies are required for main circulating pump strainers, filters, chemical rooms and chemical controllers/sample boards. In addition, a dedicated back-wash connection is recommended for each filter.

Water Hydraulics

For effective water hydraulics, the levels of the pool static water, balance tank and main circulating pumps are of critical importance; examples of good design are shown here.

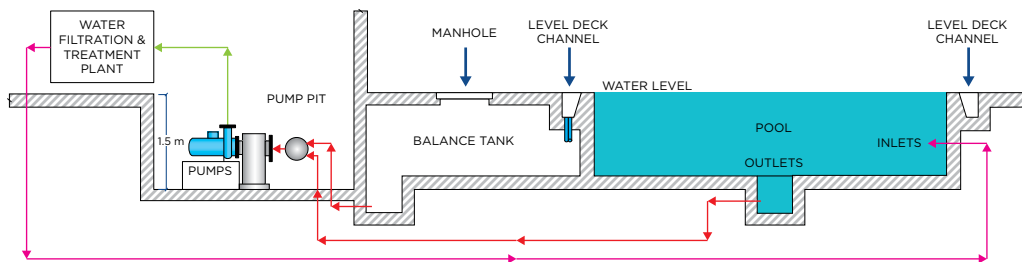

Option 1: Pool Water Treatment Plant on Same Level as Pool

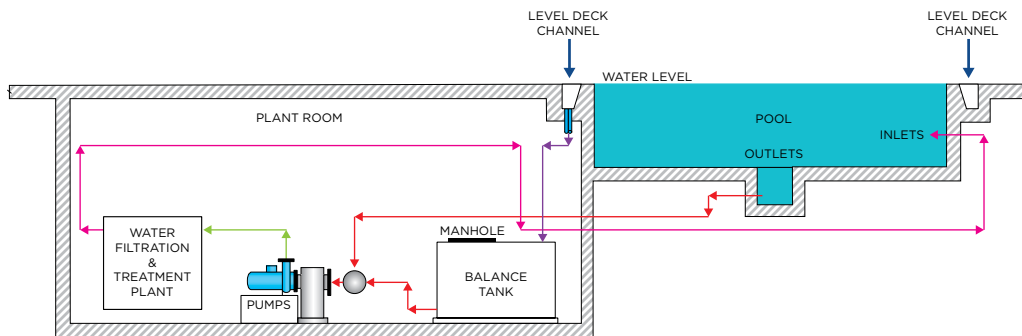

Option 2: Pool Water Treatment Plant & Balance Tank on Level Below

Space

Pool (L x W x D)	Volume	Balance Tank (L x W x D)	Plant Room (L x W x D)	Area
3 m Dia	3 m ³	1.5 m x 1.0 m x 1.0 m 60" x 40" x 40"	3.5 m x 3.0 m x 2.5 m 11' 6" x 9' 10" x 8' 2"	10.5 m ² 113 f ²
5.0 m x 4.0 m x 1.2 m	25 m ³	4.0 m x 1.2 m x 1.0 m 13' x 4' x 3' 3"	5.0 m x 2.5 m x 2.5 m 16' 5" x 8' 2" x 8' 2"	12.5 m ² 135 f ²
7.0 m x 6.0 m x 1.2 m	50 m ³	6.0 m x 1.5 m x 1.0 m 20' x 5' x 3' 3"	6.5 m x 4.5 m x 2.5 m 21' 4" x 14' 9" x 8' 2"	30.0 m ² 323 f ²

*Note: Maximum required height of full-ozone plants must be over 3 m (9' 10").

Level: Plant room slab level needs to be a minimum of one meter below the pool static water level. If this is not possible, than a pump pit should be incorporated into the plant room. Should the drainage level be higher than the pit, a recess sump should be incorporated and an automatic sump pump installed to drain.

Space: The amount of space required to house the pool filtration and water treatment plant vary considerably depending on the number and size of pools being built. Table above is supplied as a guide for spa whirlpools and vitality pools.

Health/Safety: The filtration plant room must be designed in accordance with published guidelines (e.g., Pool Water Treatment Advisory Group), and the water treatment plant arranged in accordance with good standard practice. Adequate provision has to be made for safe daily operator access and for effective and efficient ongoing service and maintenance of the entire system.

Work plinths may be required to provide access to all of the filtration and water treatment plant.

Lighting/Power: Adequate lighting and power supply outlets are necessary throughout plant and chemical rooms and should meet local/international requirements.

Ventilation/Temperature: The minimum number of air changes required in the plant room is four per hour. The temperature should not fall below 10°C (50°F) or rise above 30°C (86°F).

Endnotes

¹ <http://floatforhealth.net/suedfeld.pdf>

² http://www.epsomsaltcouncil.org/articles/universal_health_institute_about_epsom_salt.pdf

³ Refer to the German DIN 51097 standard and aim for the classification "B" (least slippery); another respected standard to follow is the British Standard Pendulum Test BS 7976-2 and BS 13036-4



Chapter Seven

Hot Springs & Geothermal Mineral Waters

This chapter covers the unique world of hot springs and geothermal mineral waters, including the health benefits of balneotherapy and was written in collaboration with the Global Wellness Institute’s Hot Springs Initiative, an international think tank dedicated to exploring the diverse values of geothermal waters for health, recreation, tourism and community.

Hot springs and geothermal waters are enjoyed throughout the world and experiencing a renaissance. Pictured: Cunnamulla Hot Springs, Queensland, Australia opened in 2024.

Wellness travelers have sought the healing power of naturally warm, mineral-rich geothermal water for millennia and hot springs have inspired healing lore and bathing rituals in virtually every culture. Hot springs and geothermal bathing are now experiencing a renaissance as modern bathers actively seek out the healing properties of balneotherapy (defined as the immersion in mineral water for health benefits).

What makes hot springs special is that no two are alike—each has a unique spectrum of minerals, temperatures, natural environments and other qualities. While most hot springs provide the familiar benefits of bathing, relaxation and places of social gathering, the unique power of hot springs is attributed to their minerals and other sensory qualities including texture, alkalinity, odor and flavor that set hot springs apart from other waters.

Geothermal mineral water is typically formed when rain and snowmelt sinks through cracks and porosities in the ground to collect in underground permeable rock called “aquifers,” that are heated by underground volcanic sources. The hot water dissolves minerals from surrounding rock and carries those minerals to the surface as the water emerges in hot springs.

Geothermal mineral waters are found as natural hot springs, geysers, streams, seeps, bogs or steam vents. They occur in mountains, valleys, deserts, and even under polar ice sheets, lakes and oceans. Hot springs may be extremely hot or barely warm; some have strong odors while others are neutral. The water may be salty, bitter, sweet, hard or soft, nutritious for microbes and plants or relatively sterile, even corrosive, radioactive or toxic to life.

In some cases, hot springs may be the only source of water in an area, while, in other cases, hot springs will be found adjacent to streams, lakes or seawater. In addition to bathing and soaking, the water from hot springs can also be used for drinking, mind/body cleansing, heating buildings and even generating electricity. Some hot springs facilities combine all of those functions, making them one of the earth's most sustainable and renewable resources.

Hot springs are the oldest and most sustainable place-based businesses with two Japanese Onsen operating continuously for over 1300 years. Today, regional, national and cultural preferences provide a guide for the design of hot spring facilities, and the experiences on offer and wellness travelers can seek out numerous types of hot springs—from rustic to luxurious or indigenous to modern urban. Visitors can soak for an hour or a day and can find hot spring facilities that suit their personal preferences—be it a contemplative spa with massage and yoga, family recreation with a water slide, or medical oversight with full laboratory services provided by doctors funded by health insurance.

Hot Springs have inspired healing and bathing rituals in cultures around the world. Modern day wellness travelers can explore these unique destinations to refresh, revitalize and re-connect with themselves, each other and the nature around them.



Bolian Hot Springs, Chongqing, China provide an idellic natural setting for re-connection.

Lake Heviz, Hungary is the largest swimmable geothermal lake in the world.



Hot Springs History

Archaeological evidence reveals our Cro-Magnon and Neanderthal hominid ancestors used hot springs sites for at least 200,000 years as health and wellness destinations. Our predecessors relied on hot springs year-round for hunting and foraging, drinking, easing the body, and harvesting of minerals including salt. The water and warmth provided year-round habitat for countless species of plants and animals through winters, ice ages and global catastrophes.

Natural undeveloped hot springs still exist today, often in remote wilderness or in areas that have challenging terrain and/or access. Adventurous hikers will often build basic pools and diverse systems that encourage air-cooling of the steamy water or devise a way to mix it with colder water, creating a comfortable soaking temperature.

Ancient Hot Springs and Drilled Wells

For much of human history, naturally flowing hot springs were the only source of warm water in which to bathe. In many places where hot water rises to the earth's surface under its own pressure early cultures used hand tools to dig small pools where they could submerge their bodies into the mysteriously warm water.

While springs naturally flow to the surface without the aid of pumps, today, well drilling technology and geological science enables access to geothermal mineral water from deep aquifers up to several kilometers down bringing hot water to the surface in places where natural springs have never freely flowed before.

Some wells are able to produce water that flows to the surface by itself without a manual pump—this is called “artesian flow,” while other wells require pumps to lift the water to the surface. Facilities built on drilled wells are commonly called “hot springs” even though a man-made well is not technically a “spring”. and many modern hot springs today are a hybrid of a spring and well because they have utilized drilled wells and pumps to enhance the water flow rate and increase pool bathing capacity.

All languages have words to describe both natural springs and wells and for ease of understanding, the term “hot springs” is used to define all geothermal mineral water facilities built on either naturally occurring springs, drilled wells, or their combination.



Hot springs provide natural social setting as seen here at Australia's Peninsula Hot Springs.

“Hot Springs” vs “Wells”

Hot Springs

- Hot springs may have historic and pre-historic use by humans
- Hot springs generally have a unique biology and can be inhabited by extremophiles
- Hot springs have unique mineral compositions.
- Ancient animal migration paths lead to hot springs, where the waters were used for hydration, salt or other minerals, and healing.
- Hot spring aquifers may have elaborate underground channels emerging at springs

Wells

- Wells can provide geothermal mineral water in areas where no natural hot springs occur
- Wells rely on aquifers for their geothermal mineral water and risk depleting this precious water resource

Some geothermal water is prehistoric, having been underground for thousands of years—similar to oil deposits that don't have access to the surface until a well is drilled, and are non-renewable or replenish very slowly. Sustainable use of an aquifer depends on how long it takes to naturally recharge the water that is extracted. Most developed countries have regulations to ensure aquifers are used sustainably and that extracted water does not deplete them.

Naturally flowing hot springs can be endangered through over pumping from aquifers for agriculture and urban use. Because aquifers are hidden underground, their complex flow and replenishment dynamics are often debated as politics collide with theoretical assumptions and available science. Regional water-laws often rule who can use the water, and for what purposes, especially during drought cycles. Hot springs and any unique species inhabiting them may be disadvantaged by the demands of industry and

global population sprawl. For example, poorly understood microbiomes of hot springs have sometimes been destroyed before they are fully documented or understood. This highlights the ongoing issue of human need versus habitat and resource conservation.

Today's wellness travelers are increasingly conscious of their ecological footprint and the sustainability of resources. Many hot spring facilities act as guardians of their natural waters and share what they know about their water, from source-to-bathing, which is considered an industry best practice.

Facilities

Pool Design

Natural geothermal springs are likely the very first type of hot-water bathing humans experienced, and are the first “spas” and original wellness destinations. Cultures throughout the ages have endowed hot springs with magical or spiritual powers for mystical awakening, sacramental drinking, anointing, physical healing and various religious rituals, including baptism.

Modern wellness travelers can enjoy hot springs in diverse locations and regions, all with unique experiences. Some facilities are designed into natural landscapes for an organic, natural experience, while others are fashioned on ancient and modern architecture. Some hot springs facilities offer a quiet, meditative atmosphere for self-reflection where contemplative inner focus is enabled. Some are more social or interactive; and others are for family recreation with waterslides, campgrounds and other complementary activities.

Facility designs consider natural flow and form while providing the best possible user experience seen here at Germany's Toskana Therme Bad Orb.



Medical hot springs are popular in countries where the water is part of a health cure and some treatments are partially funded or fully funded by insurance companies or national health-care programs. They may offer full medical treatments prescribed by doctors that can include soaking, drinking and resting in hot springs waters and the surrounding environment.

To accommodate cultural, and often religious differences, some facilities offer designated areas or days for women, men, and families to bathe separately. Some regions have modest clothing requirements relative and appropriate to their culture, while in other regions nudity or clothing-optional is the norm.

Certain regions have long-standing cultural traditions to follow or honor, while others are entirely informal and non-traditional. For the global wellness traveler, it is important to be aware of these traditions since bathing against cultural practice may be offensive or even illegal. It is therefore advised to adhere to the general culture and specific rules regarding bathing in each location.

Practical pool design information can be seen in Chapter 6.

Wellness Experiences

A broad and growing range of wellness experiences can be found at hot springs globally, complementing the core bathing experience and often ‘packaged’ for guests within the operators’ options.

Wellness experiences offered at hot springs often incorporate traditional and complementary medicine. According to the Global Wellness Institute, this includes “diverse medical, healthcare, holistic, and mentally or spiritually-based systems, services and products that are not generally considered to be part of conventional medicine or the dominant health care system—including homeopathic, naturopathic, chiropractic, Traditional Chinese Medicine, Ayurveda, energy healing, traditional/herbal remedies and supplements, etc.”

In Western countries, the offering of such wellness experiences is growing, alongside consumer adoption of traditional/indigenous, complementary, alternative and integrative medical practices outside of the conventional/western medical system.

Landscaping

Hot springs destinations very often hold outdoor appeal, with pools and other relaxation areas/activities set into the local surroundings. Landscaping is therefore usually fundamental to the experience.

Hot springs destinations are often referred to as ‘therapeutic’ or ‘healing’ landscapes. The best landscaping examples tend to embrace the visitor and accentuate the local natural surroundings.

For the same reasons that shinrin-yoku (forest bathing) is an important complementary therapy worldwide, effective hot springs landscaping can enhance the guests’ experience immensely.

Hot springs often provide a connection to local culture as seen at Peninsula Hot Springs, Australia.



Arts, Culture and Events

Worldwide, industry leaders are discovering cultural tourism is a popular offering at hot springs and the Global Wellness Institute Hot Springs Initiative (GHSI) reported arts, culture and events at hot springs is a key global trend in 2023. Among the top five trends GHSI members reported was: “connecting visitors to the local culture and nature helps deliver higher yields and longer stays in destinations”.

The report further detailed benefits of this trend as: “Hot springs-lead wellness destinations focus on working with local communities and the natural environment to provide the best possible guest experience. This results in extended stays, higher yields and repeat visitation for the businesses and the entire region.”

Culture & Etiquette

In designing, constructing, and operating hot springs facilities, it is important to accommodate cultural and often religious differences. Some facilities offer designated areas or days for women, men, and families to bathe separately. Some regions have modest clothing requirements relative and appropriate to their culture. While in some regions nudity or clothing optional is the norm, in other countries this may be strictly forbidden.

Certain regions have long-standing cultural traditions to follow or honor, while others are entirely informal and non-traditional. For the global wellness traveler, it is important to be aware of these traditions since not bathing to cultural practice may be offensive or even illegal.

Ensuring cultural and etiquette sensitivities are met in facility design and guest behavior is a fundamental responsibility of the hot springs owner and operator. This is best done through consultation with local communities and following local regulations and guidelines.



Sand bowls and other creative wellness experiences can be offered at hot springs in all weather conditions. Winter at The Springs Resort, Pagosa Springs, Colorado, USA.

Hot Springs Temperature Range

Some hot springs emerge from the ground at the perfect temperature for human bathing, while others are either too hot or barely warm, so they must be cooled or heated by non-natural means for human use.

Water temperature is easily described as “hot, warm, tepid and cold.” The temperature of a baby’s bath is probably good for long-term soaking, while very hot or ice-cold water is good for a quick dip. The word “hot” can mean many different degrees of temperature, which varies from culture to culture.

Human bodies tolerate a narrow range of water temperature for bathing. Generally, a comfortable range is between 35°C (98°F) to a high of 42°C (106°F). Hot temperatures above 43°C (111°F) are typically too hot for most people.

Unique Biodiversity and Species

Many unique species have evolved to inhabit certain springs, including aquatic plants, algae, fungi, fish, crustaceans, amphibians and insects and a wide range of microorganisms. Some of these are extremophiles, meaning they tolerate extreme environments such as heat and high mineral concentrations. One classic example is the Julimes Pupfish that lives in a single Mexican hot springs location, with temperatures up to 45°C (114°F), along with a hot water snail and the various algae they eat. That temperature is far too hot for most humans to tolerate and very few organisms can survive in such hot water.

Green and blue-green colonies of single-celled photosynthetic plants thrive in mineral-rich waters and are often used as scrubs and masks for the body and skin. Muds, peats and surrounding soils can also be used for body treatments, each with their own complex of microbiome species unique to each hot spring.

The genetic repertoire of these “hot spring specific species” offers a glimpse into how adaptation can occur within challenging concentrations of minerals.

Conservation of these species is critical to maintain their genetic diversity and future benefit to science and medicine. Encroaching developments and aquifer threats have led to closure of some hot springs to protect threatened species from extinction.

Hot Springs Sanitation

Like all public bathing waters, hot springs must be monitored for pathogens that could cause disease. Some facilities have sufficient water flow and/or drain and clean the pools each day so that no sanitizing chemicals are needed. Other facilities may require sanitizing chemicals or treatments to maintain healthful water quality.

While there is no consensus on best practice, most “hot springs” facilities, spas and resorts are monitored for water quality and regional governments often mandate specific sanitization requirements. Wild hot springs may have signs warning of various water-borne pathogens, aquatic insects or hazardous elements in the water.

Most facilities have excellent information about their waters—reviewing these is highly recommended. Be sure to inquire ahead of time regarding clothing and bathing protocols. Some facilities encourage silence in pool areas to allow a meditative atmosphere, while others are more social and interactive.

It is considered good etiquette and a standard operating procedure to require all guests to shower before entering a public hot springs to keep soil, lotions, oils, scents and sunscreen out of the shared water to ensure a clean and healthy bathing experience.

Before You Visit

Most facilities have excellent information about their waters—reviewing these is highly recommended. Be sure to inquire ahead of time regarding clothing and bathing protocols as some countries require specific clothing and may segregate women and men, while others will be clothing-optional or no clothing allowed. Some facilities encourage silence in pool areas to allow a meditative atmosphere, while others are more social and interactive.

Generally, it's good etiquette to privately bathe or shower before entering a public hot springs to keep lotions, oils, scents and sunscreen out of the shared water.

Taking the Cure

Throughout history, people have reported “cures” of various ailments and a general boost in health and vitality from soaking in the waters. Nearly all hot springs facilities can provide health benefits derived from their unique mineral waters. Robust medical research, particularly in Europe, has proven the benefit of hot springs for specific ailments— often referred to as “cures.” Some cures are directly related to trace minerals or major concentrations of macro minerals, many of which are directly absorbed through the skin and then circulated through the body. Other cures are related to temperature, viscosity, alkalinity or other properties of the water.

“Feeling better” is difficult to quantify scientifically, but it is evident that humans throughout history have been feeling better from bathing in hot springs (balneotherapy). Many visitors to these waters believe them to be healing in a physical or spiritual way. Muds and algae from hot springs may be used as body scrubs or masque spa treatments, with benefits coming from the minerals and their unique microbial species and thermal mass.

Cold-water springs can also hold many of the properties found in geothermal mineral water as they are usually created water that was very hot underground but has cooled on its way to the surface, retaining much of the dissolved mineral content. Health claims for cold water springs usually relate to drinking water, since it's too cool for soaking. This water is often bottled and shipped globally.

Ancient humans relied on their senses and local lore to understand the merits of hot springs, the same process used to discern medicinal and nutritious plants throughout history. Modern technological analysis can supplement and validate the ancient lore while providing additional levels of knowledge that expand the story of water.

Many hot springs facilities provide detailed laboratory analysis of their water chemistry, along with recommendations for bathing and drinking, however, not all hot springs waters are healthful or nutritious—some may contain harmful levels of elements including radium, arsenic or fluoride, while some minerals are beneficial only in small amounts and can be hazardous if consumed in excessive quantities.

Balneology

Classically, the study of Balneology (the science) and Balneotherapy (the treatment) have looked to three realms of application:

- Prevention/Wellness - The use of geothermal mineral springs and geothermal wellness facilities to keep the body healthy.
- Active Treatment - The use of geothermal waters and geothermal health facilities as part of a medically supervised course of treatment for a variety of active diagnosis.
- Rehabilitation - The use of geothermal waters and geothermal rehabilitation centers for recovery of function after injury or post-acute disease states.

Geothermal mineral water has long fascinated both scientists and physicians. Herodotus, one of our earliest historians (born around 484 BC) was the first to describe the use of springs and spas for the treatment of various diseases, prescribing a 21-day limit to therapy duration, while Hippocrates, Asclepieades, Pliny the Elder and Galen all advocated bathing for a range of conditions in different types of water. In addition, the Austrian physician Caspar Schober wrote a treatise in the early 16th century that described a method for analyzing the German Gastein hot springs to examine their therapeutic effects.

In the 1900s, research into hot springs explored their benefits for a wide range of clinical conditions. There is a 1940s paper on the treatment of venereal diseases; research on the benefits of thermal springs treatment for polio survivors, including Franklin D. Roosevelt's rehabilitation at Warm Springs, Georgia; and post WWII research hypothesizing a potential cure for deafness through vapor from the Brazilian Pocos de Caldas hot springs. In this century, studies have aimed to explain the functions of the various specific mineral elements in balneotherapy—such as sulfur, magnesium or radon—linking individual minerals to the treatment of particular diseases, like sulfurous-rich water and recurrent upper respiratory tract infections.¹

An example of balneotherapy's effectiveness comes from research published in *Clinical Rheumatology* (May 2018), which studied 100 patients with fibromyalgia syndrome over

a 15-day balneotherapy cycle at Levico Terme Spa Center located in Trento, Italy. Half the patients participated in passive balneotherapy in highly mineralized sulfate water, while the other half bathed in plain tap water. The 50 patients that were randomly selected for balneotherapy treatment showed significant improvements in pain and other symptoms—even when measured at two weeks, three months and six months post treatment—while the 50 patients in the control group showed no significant changes.

Types of Balneotherapy

Balneotherapy is the immersion in mineral water and/or peloid (geothermal mud/clay) for specific health benefits. Balneotherapy is sometimes confused with hydrotherapy (the use of water for relaxation, pain relief and other treatments). Maintaining a universal definition of ‘balneotherapy’ is important both for global research and the industry as a whole. Readers should note that the standardized definition of balneotherapy as agreed by the Global Wellness Institute’s Hot Springs Initiative is “passive bathing in geothermal mineral spring waters with water content that is regarded as having unique health properties.”

Various types of balneotherapy can be identified, including:

European Program: European balneotherapy programs are well documented and often studied. They usually consist of passive 20-minute bathing sessions two or three times a week over a course of three weeks.

Peloid Therapy: Refers to the use of mud/clay from geothermal environs.

Hot-cold Immersion: Hot springs bathing followed by cold plunge (or increasingly, ice immersion) is a common balneotherapy practice. Saunas, hammams and steam rooms can also be used as heat sources.

Inhalation: Refers to therapies that focus on inhalation of geothermal mineral spring water gases.

Some hot springs emerge from the ground at the perfect temperature for human bathing, which is often referred to by experts as the “Goldilocks Zone” because the water is considered “just right.” Pictured: Maruia Hot Springs, South Island, New Zealand.





Mud is used in Peloid Therapy as seen at Piestany, Slovakia.

Watsu: Increasingly common treatment that utilizes the elements of Shiatsu while floating in hot spring waters.

Geothermal Water Exercise Programs: Unlike passive balneotherapy, these programs involve performing yoga and other stretches in geothermal waters. These can also involve the use of underwater aqua bikes designed to provide resistance.

Reflexology: Stone walks through geothermal mineral water.

Thermal Sound Therapy: Floatation while music is played underwater.

Health Resort Medicine: Balneotherapy within a resort setting and including related treatments during the visit/stay. These additional balneotherapy program treatments might include massage, nutritional programs, yoga, pilates, meditation, hydrothermal exercise therapy, physiotherapy and many more.

Hammams and Steam Rooms: High temperature and humidity rooms designed to encourage sweating and within which specific scrubbing and massage treatments can be provided.

Classification Confusion

Unfortunately, there's no global agreement on hot springs classification. Instead, balneologists around the globe often create classifications of geothermal mineral springs in silos, with little or no collaboration. The lack of a unifying and globally-accepted classification system means that researchers—along with industry groups—continue to create their own.

For the purposes of this guide, we present a classification list created by the Australian Hot Springs industry, which published a national classification protocol in 2018 that is based on the fundamentals of the more regulated definition of Japanese 'onsens' (the term for the popular hot springs and bathing experiences found all over Japan).

Australian Hot Springs Classification

Hot springs are classified according to four criteria: well temperature, pH, osmotic pressure and type of spring.

1: Well Temperature

Cold Spring: up to 20°C (up to 68°F)

Warm Spring: 25°C to 34°C (77°F to 93°F)

Hot Spring: 34°C to 42°C (93°F to 108°F)

Extra Hot Spring: over 42°C (over 108°F)

2: PH

The pH of the water has a large effect on how the water feels. The more alkaline the baths, the softer and soapier the water feels. Alkaline baths are thought to be good for the skin and are also called “beauty springs”. Acidic baths will, conversely, feel much harder or firmer on the body. Both sensations are enjoyable and a matter of personal preference.

Acidic: pH of 3 or lower

Weak Acidic: pH of 3 to 6

Neutral: pH of 6 to 7.5

Weak Alkaline: pH of 7.5 to 8.5

Alkaline: pH of 8.5 or greater

3: Osmotic Pressure

This is the total weight of the dissolved solids in a given amount of the spring water and the water’s ability to hold those minerals in suspension. The difference is often visible as spring water that contains a high percentage of dissolved solids will typically be opaque.

Low: 8g/kg of dissolved solids or lower and a freezing point of -0.55°C or higher

Isotonic: 8g/kg to 10g/kg of dissolved solids with a freezing point of -0.55°C to -0.58°C

High: 10g/kg or higher and a freezing point of at least -0.58°C

4: Hot Spring Types (More Details On Next Page)

- Simple Hot Spring
- Chloride Springs
- Carbonated Springs
- Sulfuric Acid Springs
- Iron Springs
- Aluminum Springs
- Radioactive Springs

4: Hot Spring Types (Based On Japan's "onsen" classification.)

Simple Hot Spring: Water that does not contain enough minerals to be classified in detail but are still considered onsen.

- Simple hot spring
- Simple alkaline hot spring

Chloride Springs: The most common type of hot spring in Japan. The salt content helps clean the body of sweat while helping the body retain heat.

- Sodium chloride spring
- Strong sodium chloride spring
- Sodium chloride carbonated spring
- Sodium chloride sulphate spring
- Sodium and calcium chloride carbonated spring

Carbonated Springs: These may have a softening effect on your skin and leave the body feeling refreshed and cool after bathing.

- Sodium and calcium bicarbonate spring
- Calcium and sodium bicarbonate chloride spring
- Calcium and sodium bicarbonate sulphate spring

Sulfuric Acid Springs: These springs help reduce pain, combat liver disease and constipation. The calcium type also has a calming effect. The magnesium helps lower blood pressure.

- Calcium sulphate spring
- Sodium sulphate chloride spring
- Magnesium sulphate spring

Iron Springs: The iron in the spring is absorbed by the water and helps in blood production. Although these springs are clear when they emerge from the earth, the iron in them will oxidize and turn a brownish color.

- Iron carbonated spring
- Acidic iron sulfuric acid spring

Aluminum Springs: These springs may have disinfectant properties and benefit some skin diseases.

- Aluminum and iron sulphate spring

Radioactive Springs: The radon is absorbed into the body and breathed in as the gas escapes from the water. The use of radioactivity for positive medical effects is greatly debated but has been done for many years. Radon caves where people go to breath in the gas for therapeutic reasons are still in operation in parts of North America. One should use their own judgment when deciding to expose themselves to radioactivity like this.

- Simple radioactive spring
- Simple weak radioactive spring

The Chemistry of Mineral Water

Hydrogen sulfide is a chemical compound known for its “rotten egg” smell, and its role as an analgesic has received the most scientific attention, including a 2013 study that appeared in the *European Journal of Inflammation*² and another in the same year entitled “Sulfureous thermal water increases the release of the anti-inflammatory cytokine IL-10 and modulates antioxidant enzyme activity.”³

Magnesium in geothermal water has been attributed to successfully treating dermatological conditions,⁴ while radon-enriched hot springs are thought by some to increase the body’s resistance to cancer by elevating p53 protein levels.⁵

The effects of balneotherapy on chronic pain have been studied extensively. A 2015 review of 27 studies, concluded there is a high level of evidence that spa interventions reduce chronic pain and analgesic consumption and improve function and quality of life, in chronic low back pain and knee osteoarthritis cases. Another review found “100% positive outcomes for clinical improvement, pain alleviation and improved quality of life,” a finding that was backed five years later by another systematic review which concluded that balneotherapy “is an effective remedy for lower back pain, as well as knee and hand osteoarthritis.”

An overview of minerals and their benefits:

- **Boron** encourages healthy bone development and building muscle mass. It helps manage arthritis and osteoporosis and boosts brain activity.
- **Calcium** promotes healthy bone growth. Maintaining proper levels of calcium reduces chances of colon and breast cancer.
- **Chloride** is essential for the proper balance of body fluids. An electrolyte, it helps maintain proper blood volume, blood pressure, and pH.
- **Fluoride** promotes hardness and stability of bones and teeth.
- **Iron** increases resistance to stress and disease, as well as preventing fatigue. It also promotes healthy skin, hair and nails.
- **Lithium** has a calming and mood-stabilizing effect. It promotes brain health and alleviates depression.
- **Magnesium** is important for the breakdown of fatty acids and cholesterol. It helps maintain hormone levels, along with regulating heartbeat and blood pressure.

Thermal bathing in Slovenia.





Connecting with nature at Metung Hot Springs, Victoria, Australia.

- **Manganese** also assists in the breakdown of fats and cholesterol. It contributes to healthy bone metabolism and growth.
- **Nitrogen** is needed to make proteins in muscles, skin, hair and nails.
- **Phosphate** is critical for energy storage and metabolism. It assists in kidney, muscle and nerve function.
- **Potassium** reduces high blood pressure and cholesterol. It is also vital for heart and kidney health.
- **Silica** is not considered an essential nutrient, but studies have shown that it can prevent the thinning of hair and plays a vital role in assisting calcium in bone growth.
- **Sodium** is another electrolyte that is necessary for life and plays a pivotal role in fluid balance, enzyme operations, and nerve and muscle functions.
- **Sulfate** is a compound found in every cell of the human body. It helps relieve nasal congestion and is essential for production of collagen and maintaining healthy skin, hair and nails. It also helps flush toxins and purify the body.
- **Zinc** helps with proper functioning of the immune and digestive systems. It plays a key role in thyroid function and healthy vision.

Social, Environmental and Economic Impacts

As of 2023 a PhD research study at Victoria University in Australia were finalizing a set of indicators as a tool to measure hot springs' socio-cultural, environmental and economic impacts and potential regenerative impacts in communities and highlight ways they can contribute to the regenerative improvement in the quality of life.

Progress on and delivery of the indicator set can be found at the Global Wellness Institute's Hot Springs Initiative resource library. Operators can access these tools to understand and enhance positive impact within their local communities. The Hot Springs Initiative welcomes hot springs to join a long term global best practice study enabling participating facilities to share knowledge and learning.

Hot Springs Derivatives

Throughout the globe a variety of hot springs derived and related products have been developed to enhance and extend the bathing experience. Examples of these include:

- Hot springs sprays and mists
- Hot springs face masks
- Foods cooked in hot springs such as eggs, breads, meat and vegetables
- Hot springs bath salts
- Hot springs mineral water for drinking

Staffing, Education and Skillsets

Hot springs staff education and training is emerging to create career paths for the industry sector worldwide.

At the time of this edition, development of a Diploma of Hydrothermal Wellness was underway in Australia. This one-year full time Diploma will develop cohorts of graduates to fill the many job opportunities and lead to career pathways arising from the growth of the Australian hot springs and urban bathing sectors. Similarly, a degree in hot springs management was developed in China at the Hot Spring College of Hezhou University. The program began recruiting students nationwide from September 2023 to cultivate hot spring professionals.

With gratitude to the organizations that made this chapter possible:

BATHING
AUSTRALIA

Bathing Australia
www.bathing.org

Chisholm

Chisholm Institute (Australia):
www.chisholm.edu.au



Hot Springs Association (USA):
www.hotspingsassociation.com



Peninsula Hot Springs (Australia):
www.peninsulahotspings.com





Hot springs in natural surroundings let bathers get in touch with nature, while experiencing the wellness benefits of their unique water properties. Pictured: The Springs Resort, Pagosa Springs, Colorado, USA.

Hot Springs Terminology

Algae: informal term for a large and diverse group of simple organisms of aquatic or moist habitats

Aquifer: an underground layer of water bearing permeable rock

Balneotherapy: the practice of immersing in mineral water or mineral-laden mud

Extremophiles: an organism that thrives in physically or geochemically extreme environments

Balneology: the scientific investigation of geothermal mineral water effects on health and wellness

Gas: a substance possessing perfect molecular mobility and the property of indefinite expansion, as opposed to a solid or liquid

Geothermal: energy, generated and stored in the Earth that determines the temperature of matter

Geothermal Mineral Water: heated water flowing from underground sources

Ground Source Loop Heat Exchange: drilling a dry well deep enough to access the natural underground heat of the Earth, bringing that heat to the surface with fluids and transferring the heat to municipal water

Halophyte: a saline-tolerant plant species

Hot Springs: geothermal mineral water facilities whether they're naturally occurring hot springs or modern drilled wells, or a combination of both spring and well

Hydrology: the scientific study of the movement, distribution, and quality of water

Microbiomes: the microorganisms in a particular environment

Mineral: a mineral is a naturally occurring substance that is solid and inorganic and has an ordered atomic structure

Mud: wet, soft earth or earthy matter occurring in or around hot springs.

Peloid: mud, or clay used therapeutically, as part of balneotherapy, or therapeutic bathing. Peloids consist of humus and minerals formed over many years by geological and biological, chemical and physical processes

Peat: brown soil-like material characteristic of boggy, acid ground, consisting of partly decomposed vegetable matter

Primordial: ancient, prehistoric, from the beginning.

Replenish Rate: the rate at which an aquifer's water is naturally replaced

Additional Hot Springs Industry Resources

Key industry organizations and associations within the hot springs sector include:

Global Wellness Institute Hot Springs Initiative:

<https://globalwellnessinstitute.org/initiatives/hot-springs-initiative/>

World Federation of Hydrotherapy and Climatotherapy (FEMTEC):

<https://www.femteconline.org/>

China Hot Springs Association: <http://www.chsta.cn/>

Hot Springs Association (USA-based): <https://hotspringsassociation.com/>

Termatalia: <https://www.termatalia.com/>

European Spa Association: <https://europeanspas.eu/>

ESPA also has a library of balneological research: <https://europeanspas.eu/e-library/>

Polish Geothermal Association: <https://energia-geotermalna.org.pl/> and <http://www.pga.org.pl/>

European Spa Foundation: <https://fundacjaspa.org/>

The Association of Polish Spa Communities: <https://sgurp.pl/en/>

Australian Hot and Mineral Springs Bathing Alliance: <https://www.bathing.org/>

Academic journals which regularly publish industry-relevant articles:

Geothermics: <https://www.sciencedirect.com/journal/geothermics>

Environmental Research: <https://www.sciencedirect.com/journal/environmental-research>

Journal of Hydrology: <https://www.sciencedirect.com/journal/journal-of-hydrology>

International Journal of Spa and Wellness: <https://www.tandfonline.com/toc/rspa20/current>

Wellness tourism studies:

Wellness Tourism is consistently one of the fastest growing tourism segments. The Global Wellness Institute's Wellness Tourism Initiative monitors worldwide trends each year. The 2023 trends can be found at <https://globalwellnessinstitute.org/global-wellness-institute-blog/2023/06/26/wellness-tourism-initiative-trends-for-2023/>

Endnotes

¹ Salami, A., M. Dellepiane, B. Crippa, F. Mora, L. Guastini, B. Jankowska and R. Mora (2008). "Sulphurous water inhalations in the prophylaxis of recurrent upper respiratory tract infections." *International Journal of Pediatric Otorhinolaryngology* 72(11): 1717-1722.

² Carubbi, C., G. Gobbi, G. Bucci, M. Gesi, M. Vitale and P. Mirandola (2013). "Skin, inflammation and sulfurous waters: What is known, what is believed." *European Journal of Inflammation* 11(3): 591-599.

³ Prandelli C, Parola C, Buizza L, Delbarba A, Marziano M, Salvi V, Zacchi V, Memo M, Sozzani S, Calza S, Uberti D, Bosisio D. Sulphurous thermal water increases the release of the anti-inflammatory cytokine IL-10 and modulates antioxidant enzyme activity. *Int J Immunopathol Pharmacol.* 2013 Jul-Sep;26(3):633-46. <https://www.ncbi.nlm.nih.gov/pubmed/24067460>

⁴ Proksch, E., H. P. Nissen, M. Bremgartner and C. Urquhart (2005). "Bathing in a magnesium-rich Dead Sea salt solution improves skin barrier function, enhances skin hydration, and reduces inflammation in atopic dry skin." *International Journal of Dermatology* 44(2): 151-157.

⁵ Yamaoka, K., F. Mitsunobu, S. Kojima, M. Shibakura, T. Kataoka, K. Hanamoto and Y. Tanizaki (2005). "The elevation of p53 protein level and SOD activity in the resident blood of the Misasa radon hot spring district." *J Radiat Res* 46(1): 21-24.



Chapter Eight

Construction Materials & Building Services

This chapter covers the major engineering and management elements of a hydrothermal spa. It's designed to give readers a closer look at the “behind-the-scenes” operations that bring a spa design to a working reality, including the ventilation, drainage, electrical services and lighting. The choices made in building services also play a key role in the overall environmental impact of a building—something that is relevant both in domestic and commercial builds of hydrothermal areas.

A calm and confident front desk is the result of a well thought out hydrothermal build that not only appears inviting but also operates so smoothly that guests are unaware of anything going on behind the scenes.

Please note, this chapter is meant as a general guideline and it's important to work with specialists who have local knowledge on the standards and codes to follow.

Before getting into the technical, behind-the-scenes working of a hydrothermal spa and all the specific considerations that must be made when embarking on one of these complex builds, we are providing readers with an inside look at how these builds come together from beginning to end. The pictorial on the following pages clearly illustrates how new advances in building and construction—specifically, factory-controlled prefabrication and on-site assemblage—are shaping the future of hydrothermal areas. It shows just how much of the work can be accomplished offsite (a big bonus if the facility is already in use) by pre-configuring hydrothermal areas in environmentally-friendly, easy-to-customize hard foam support material that can then be shipped and assembled onsite.



Taking a concept design and turning it into a fully working hydrothermal area requires numerous steps. This is the end result of an extensive hydrothermal shower area for Fitness Palace in St. Petersburg, Russia.

Stages of a Hydrothermal Spa Build

As discussed in Chapter 3, a lot of resources go into the planning and design of a hydrothermal area. Once the concept and general design parameters are in place, it's time to get to work building!

So how do the concepts and experiences that an entire team has agreed upon make it from paper to reality? In the following pages, there are two examples showing architectural concept drawings and the process of prefabrication using hard foam. Example 1 is Fitness Palace, a high-end fitness studio located in St. Petersburg, Russia that wanted to completely refurbish its male and female shower areas with only 30 days of downtime. A St. Petersburg consultancy, LV Studio, led the design of the area.

As is common in most of today's hydrothermal builds, the Fitness Palace project was constructed of prefabricated hard foam—which is not only environmentally friendly and ideal for a moisture-rich environment but also enabled much of the work to take place off premises so that the building could operate as normal for as long as possible.

Note: The following build examples and images provided by Lux Elements GmbH.

Example 1: Fitness Palace

1: Idea and Planning

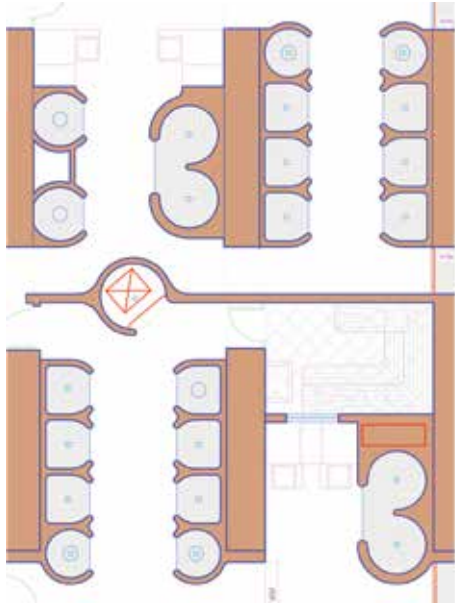

Plan shows separate male and female shower complexes featuring multiple shower experiences, foot spas and a sauna.

2: Technical Drawings

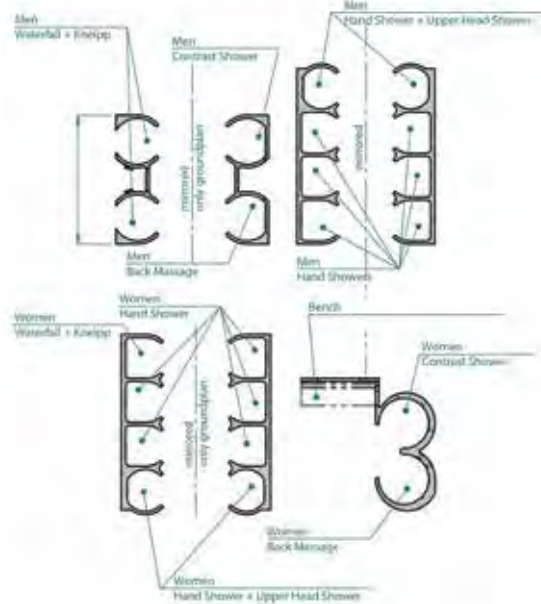

The labeled technical drawing indicates the intended functions of each area.

3: 3-D Drawings

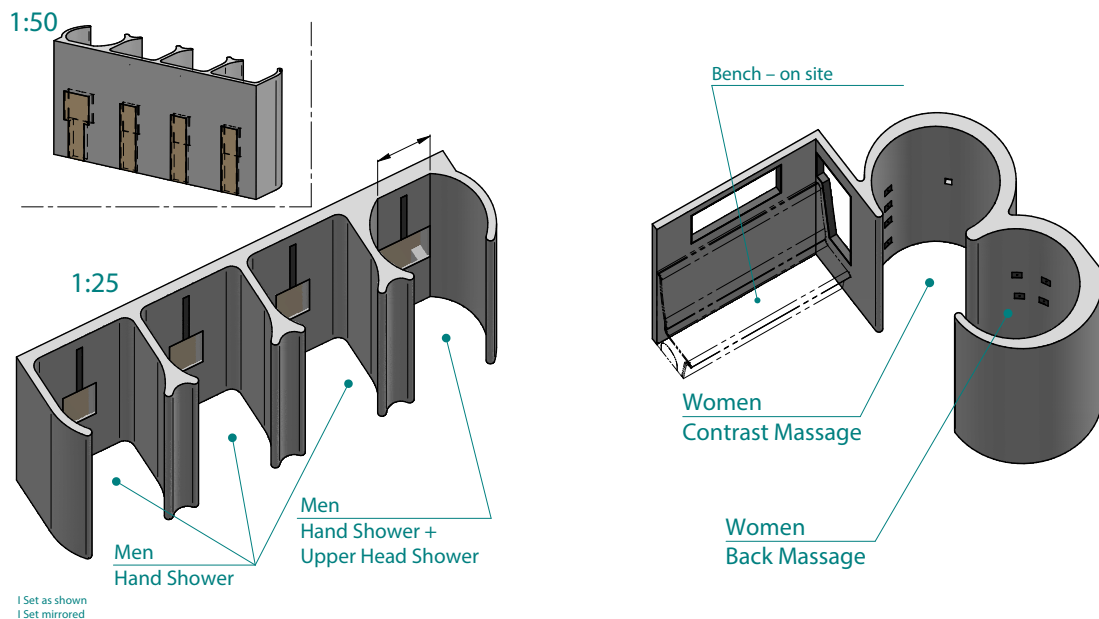

3D drawings are then created showing the scope of the prefabricated shower complex that will be manufactured in hard foam and will be the base for the completely waterproof, finished product.

4: Pre-Assembly



While still in the factory, boards are routed for pipes, shower valves and conduits to carry wiring for buttons and lighting. Pre-plumbing even takes place in the factory. The pipes and conduits are stubbed out at ceiling height ready for site connection by the various on-site subcontractors and engineers.

5: Pre-Assembly: Dry Wall



Once completed in the factory, all components are dry built before shipping and labeled for easy on-site assembly. Pre-assembling in the factory eliminates any unwanted surprises at the building site.

6: On-Site Construction



Once on site, the installation commences and all the components are set out and glued together. Services are connected, with convenient niches between the showers that enable access panels. Work is easily coordinated with local contractors, such as drywall and tiling contractors.

This Is Transformed...



...Into This!





Example 2: A 45-square-meter (484 sq ft) hamam in a NYC residential tower, includes integrated hot water heating in walls and floor, and features multiple heated-stone lying areas.

Example 2: Hamam

Technical Drawings

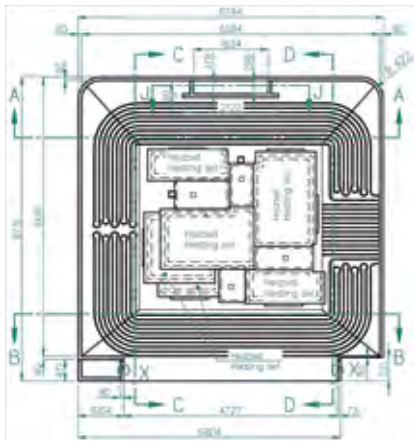

Pre-Assembly



On-Site Construction



Ventilation and Climate Control

Regardless of the type of thermal room or cabin—sauna, steam bath, hamam, relaxation room, etc.—proper ventilation and climate control are crucial to the bathers' comfort and health and significantly impact the effectiveness of the thermal room. A heating, ventilation, air conditioning (HVAC) contractor must be engaged for this purpose and will work closely with the mechanical and electrical (M&E) consultant.

Key to proper ventilation is the supply of oxygen to the room—this is vital in artificially heated environments. Low oxygen levels will result in bathers feeling or even becoming truly unwell, including fainting or worse (see Chapter 4 to learn more about the risks of CO₂ in thermal rooms). In addition, proper ventilation will promote drying of the rooms. Mold, fungus and bacteria spores easily grow in warm, moist environments so correctly engineered ventilation will aid in the drying out of the cabins and will minimize the health risks associated with these microorganisms.

Importantly, proper ventilation is what keeps the rooms at optimum bathing temperatures and ensures correct levels of humidity are produced for the maximum benefit (especially important in a steam room). When a cabin is not run at the correct temperature or does not provide the right humidity level, the experience will not meet bathers' expectations.

The materials used to build cabins have a significant effect on the efficiency of the room and how easy or difficult it is to maintain the correct climate. If traditional building materials like concrete, blocks or drywall are used, there will be a greater likelihood that the steam generation will not function correctly. The use of efficient building materials,

Typical Steam Room Equipment and Recommendations

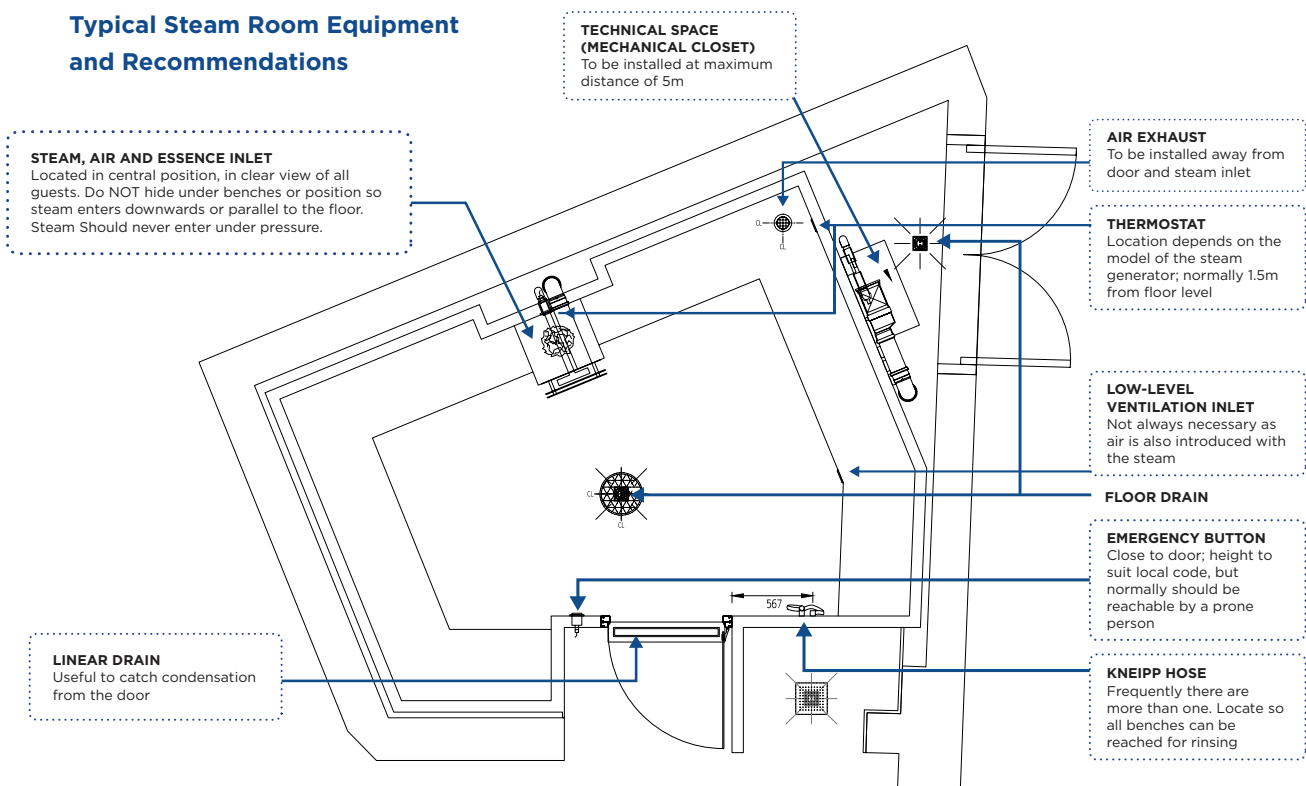

such as a coated foam board that provides maximum waterproofing and thermal insulation, increases the effectiveness of the steam generator. Even then, there will be a level of radiant heat reflected back into the room from the wall and floor finishes, which will usually be some form of tile or stone that will require ventilation.

If not ventilated properly, radiant heat can upset the temperature/steam balance. Because steam rooms and other humid/wet cabins require varying levels of humidity to be artificially created via steam generators, they will be relying on temperature probes or sensors (hygrometers) to activate the steam. If the sensors can't detect the correct temperature because there's too much heat in the room or they are incorrectly placed (e.g., too high)—an issue frequently caused by overheating the walls and benches or using inferior construction materials that absorb and emit too much heat—then the temperature/steam balance becomes unsettled, and the room is not able to function as it should.

The placement of temperature sensors needs particular attention. They are usually located approximately 1.5 m (5') from the floor (which is the approximate height of a person's head—and the most sensitive part of the body—when sitting on a bench), and, because the sensors penetrate the walls, they are susceptible to high levels of heat being radiated from the structure of the walls.

Professional steam generators can operate inlet and exhaust fans automatically to maintain and regulate the optimum cabin climate. For example, an exhaust fan will not be switched on until the cabin reaches the desired temperature. It will then extract the condensation heat accumulation until the steam bath temperature drops below the set point, which switches the generator on again.

An overrun program (drying program) keeps inlet and outlet fans running for a period after the unit is switched into standby mode. This ensures complete evacuation of the steam and assists in cooling and drying out the cabin.



Common Mistakes in Hydrothermal Builds

- Not making provision for increased air distribution around hotter temperature pools (e.g., vitality pools) and treatment plant rooms. HVAC consultant must pay close attention to the temperatures of the pools.
- Not having correct water pressure and flow rate to operate experience showers, jet showers, Vichy showers, etc.
- Not choosing a steam generator based on the quality of the local water—hard water or soft water require different systems
- Not considering that materials used for ventilation ducts have to be non-corrosive
- Lacking proper air exchange in steam rooms. Extraction fans should have the capacity to exchange the room volume at a rate of 4-6 times per hour.
- Failing to place temperature sensors and other cabling within an electrical conduit for easy maintenance.

Proper ventilation in the pool area helps minimize evaporation and controls condensation. In addition, it removes chlorine smells and other contaminants from the air and creates a comfortable environment for bathers, staff and spectators. Pool areas are generally kept between 24°C to 28°C (75°F to 82°F), but this also depends on the time of year, the temperatures of the pools in the area, etc. Getting this right is critical to bather comfort, and it is imperative that the HVAC specialist and wet area specialist work together to calculate the fresh air and air changes required, as well as the temperature that needs to be maintained in this area. Because of the higher operating temperatures in the pool area, evaporation is a key consideration when planning climate control and ventilation. Some general evaporation principles to be aware of:

- Larger water surfaces result in a greater evaporation and condensation. *Use a pool cover where possible.*
- Higher water temperature = higher rate of evaporation
- Lower indoor air temperature = higher rate of evaporation
- Lower indoor relative humidity = higher rate of evaporation
- Greater air movement = higher rate of evaporation Note that there is a theory that condensation can be significantly minimized if the air temperature is kept 1°C to 2°C (35°F) higher than that of the temperature of the pool. However, this does NOT work for vitality pools which are usually kept at 36°C (96.8°F). The air temperature will become far too hot if it's raised even just a single degree higher.

Thermal Cabin Ventilation

Typical Duct and Air Valve Materials

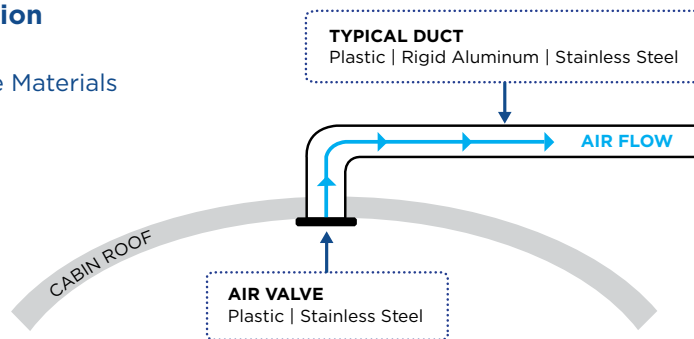

Extracting Air at High Level Using Variable Speed Fans (Preferred Method)

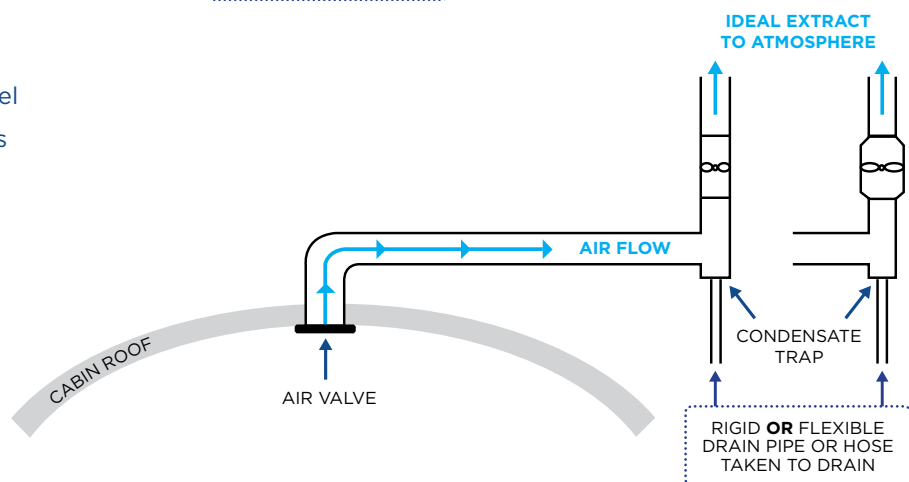



When planning a thermal room, it's imperative to include cut-outs for electrical conduits and cabin control units. Without conduits, it's impossible to perform required maintenance without damaging the walls. Image shows prefabricated walls with conduits in place.

Air and Heat Extraction Tips

Wet area specialists are well-versed in accepted standards of air and heat extraction and can advise the HVAC consultant. It's important to follow these general guidelines:

- Exhaust ductwork must be made of a non-corrosive material—plastic, aluminum or stainless steel, depending on local building department regulations and codes. Moist air, often mixed with the essence of essential oils, can be very corrosive.
- Exhaust ducting must be smooth, not flexible, to avoid condensation.
- Exhaust ducting must always fall in the direction of a condensate drain point, which should be at the lowest point in the ductwork. If necessary, more than one drain point should be provided. It is vital that all risks of pooling or lying water be removed to prevent the incubation of Legionella (the bacteria that causes legionnaire's disease, a severe form of pneumonia).
- Correct balancing of the ventilation system requires each cabin to have its own inlet and exhaust fans.
- If individual fans are not used, an electrical or manually operated volume-control damper should be installed within the duct.
- Fans should provide four to six air changes per hour and have variable speed controllers to balance airflow and ensure a slight negative air pressure in the room.
- Inlet and exhaust ducts in rooms terminate in plastic or stainless steel grilles or air valves—these are NOT intended to replace fans or volume-control dampers.
- Avoid painted or coated aluminum grilles, as the coating invariably peels off.
- Fans should be installed in a vertical section of the duct wherever possible.
- If fan is of a larger diameter than the duct, it is mandatory that it is fitted in a vertical section of the duct to avoid water condensing in the fan housing.
- Condensate traps and drains for thermal rooms are not standard pieces of equipment available “off the shelf” from HVAC equipment suppliers—the HVAC contractor should have a specialist ductwork fabricator manufacture suitable components.

Note: Local and/or national building codes also must be considered.

It is important to balance the ventilation system to ensure a slight negative pressure to minimize the loss of steam/climate. This will not, however, be able to completely stop steam being sucked out of the cabin, so it is vitally important that the HVAC contractor installs an exhaust point directly above the door, to the exterior of the cabin. This positioning is ideal because an exhaust point further away will draw the escaping hot, humid air along the ceiling and, the further it is drawn, the more it will condense and cause drips. This often causes considerable damage to ceilings, which will not have been constructed in materials or with finishes to withstand constant exposure to moisture.

Electrical Services

In today's hydrothermal spas, the electrical load required for all the specialist equipment is extensive. For example, the steam generator and sauna heater are typically electrically driven, as are the mood lighting systems featured in thermal cabins and pools, just to name a few. Electrical planning, therefore, forms an important part of the overall planning of a wet spa, especially when you also consider the in-room extras like electronically adjusted massage tables and specialist treatment devices. The amount of ampere or kilowatts required and the distribution of that power require consultation between an M&E consultant and a wet area specialist.

Of course, if the building has limited access to electricity for any reason (such as electricity is cost-prohibitive or the location is far from the power source), understanding and planning for the electrics at the earliest stages is even more crucial. If electricity is in short supply, there are alternatives that can be considered, such as heating pools using a heat exchanger or using traditional wood burning stoves in a sauna.

Because thermal rooms feature the use of heat and water, safety requirements are paramount when it comes to the electrical components and fittings. They need to be protected from both these elements through the use of waterproofing, correct heat shielding and the selection of fittings, as required by the needs of the installation.

When placing electrical socket outlets in wet treatment rooms, they should be in housings or mounting systems that are in compliance with national electrical codes.

Calculating Electrical Costs of Spa Area

1. Calculating the electrical costs of a spa area is easily done if the cost per kilowatt hour (kWh) is known.
2. Add up the total wattage (in kW) of the equipment in spa, e.g. sauna (12kW), steam room (18kW), hamam (12kW), pool (15kW) and hot tub (18kW)
3. In this example, the total load is 75kW
4. Multiply total load by operating hours per day and then the operating days per month: $75 \times 16 \text{ hours/day} \times 30 \text{ days per month} = 36,000 \text{ kilowatt hours (kWh) per month}$.
5. Multiply 36,000 kWh by the energy provider's rate (USD \$.018 in this example). Therefore, electrical operating costs will be \$6,480 per month or \$216 per day or \$13.50 per hour.

Electrical Equipment Found in Wet Treatment and Thermal Rooms, Includes:

- Aromatization/fragrance blower
- Fragrance pump (pump for single/multiple fragrances)
- Brine solution pump (pump for sterile brine solution spray)
- Bubbling system (for foot baths)
- Foam generator (for hamam massage)
- Infrared heat lamps
- Lighting—ceiling LEDs, ceiling lights over treatment tables, wall sconces, under-bench strip lights and control units for light programs, including transformers
- MP3 player
- Speakers
- Steam generator
- Steam shower
- Sauna heater
- Control panels
- Panic/emergency button connected to an external alarm
- Heating systems for floors, benches in tiled rooms



When sourcing the treatment equipment that will be using these sockets, ensure they can be locally transformed to 12/24V to minimize risk.

All wet-area electrical outlets should be protected by residual current devices that are designed to trip quickly if any water ingress causes leakage of current to earth/ground. It is important to earth/ground-metal-framed equipment; furniture and plumbing must also be earth/ground-bonded in wet areas. This also applies to metal door frames.

Often omitted in design are power sockets required for cleaning equipment. These, ideally, should be placed outside the room or within built-in cabinetry in the room. In a multi-function room where multiple treatments require varying electrical equipment, the equipment should be housed in cabinetry and the sockets enclosed within the cabinets.

Some countries have restrictions on electrical sockets being at a set distance, often 2.0 m (6' 7"), from a water source. This can be particularly restrictive if plug-in equipment is required for treatment preparations, so care should be taken in planning the preparation area to ensure a cabinet-mounted socket is within reach.

Electrical equipment within thermal rooms, e.g., sauna stoves, lamps and lighting, is normally manufactured, tested and certificated as safe for use in the environment in which it is to be used. This is why sourcing equipment from specialist manufacturers is essential. In many countries, safety codes differ between commercial and residential properties so care should be taken that, in all instances, only professional-duty products are used.

As the electrical services are a major installation, the relevant circuit boxes, breakers and other system components need to be installed and maintained. All electrical work should be carried out by qualified persons and in accordance with local regulations and permit requirements.

Fragrance pumps can power multiple aromas.

Drainage

This is one of the key components of a successful wet-room installation, as it has implications for maintenance, cleaning, health and safety. The drainage system is in place to remove water from all sources (taps, shower heads, hoses, condensation, etc.) and will also facilitate the cleaning and washing down of an area. The quantity and positioning of waste drains is key to efficient drainage, as are the quality of fittings—which can corrode quickly if sufficiently robust materials are not used. Multiple drains may be required depending on the floor area and the equipment used—for example, steam generators will require separate drainage from the waste outlet. While foot spa basins that run automatic fill and emptying programs will need an overflow outlet in case of a drain valve failure.

Drain systems should offer a high drainage capacity— not less than 42 liters/min in a normal hydrothermal room installation, and higher (minimum 60 liters/ min) for other specific applications, such as experience showers. There should be an adequate fall to each drain (usually 1:100), and care should be taken to minimize the potential for user accidents (slip and trip). Typically, slip-resistant floor surfaces are required.

Drainage grids/grates may be lockable to both prevent vandalism and ensure large objects are not evacuated into the system. In addition, traps are required on drains to prevent smells from lingering inside the piping, and drainage systems can also be connected to recycling systems to minimize waste/water pollution and improve utility efficiencies.

Land Vs. Maritime Construction

Recognizing the huge trend towards putting spa facilities on boats and cruise ships, here are some considerations to make when building wet areas that will be at sea:

- Building standards/codes for ships are set by IMO- International Maritime Organization, not other standards mentioned in this handbook
- Fire safety and smoke minimization is critical - far more so than for land-based projects
- Thermal cabins must be constructed in aluminum sheet - using the traditional “dry wall” system of metal framing, but replacing gypsum board with a single aluminum sheet on the outside, fiberglass insulation in the core and a twin-wall aluminum sheet on the inside
- Walls must then be sealed and waterproofed with resin compound and bondage



Heating and Cooling Services

Given the importance of hot and cold experiences in a hydrothermal spa, special attention must be paid to creating water and air that is the correct temperature. This can be especially challenging in regions where cold water is not available—such as in the heat of the Middle East.

Many of the features in a hydrothermal spa require cooling down versus heating. For example, snow rooms, ice fountains, cold plunge pools and spray-mist experience showers need to be chilled and cool. Depending on the location, chilled and/or cold water will either be provided by the mains or created on site. Conversely, hydrotherapy pools, onsen pools, tropical rain-shower experiences and many others are warm experiences and require heated water or air. The alternate hot-and-cool experience found in a Kneipp walk or Kneipp basin is an example of an experience that must supply both hot and chilled water at a specified temperature, in order to deliver the correct Kneipp experience.

In the Middle East and parts of Asia and Asia-Pacific, cold water is available via the mains, but it isn't usually "cold" by the time it reaches its destination. Chilled water may be provided instead, but this water is usually contaminated with chemicals and, therefore, unusable. Experts are required to solve this dilemma, and they may introduce heat exchangers to cool down the "cold" water from the taps for use in fog showers, cold plunge pools, etc.

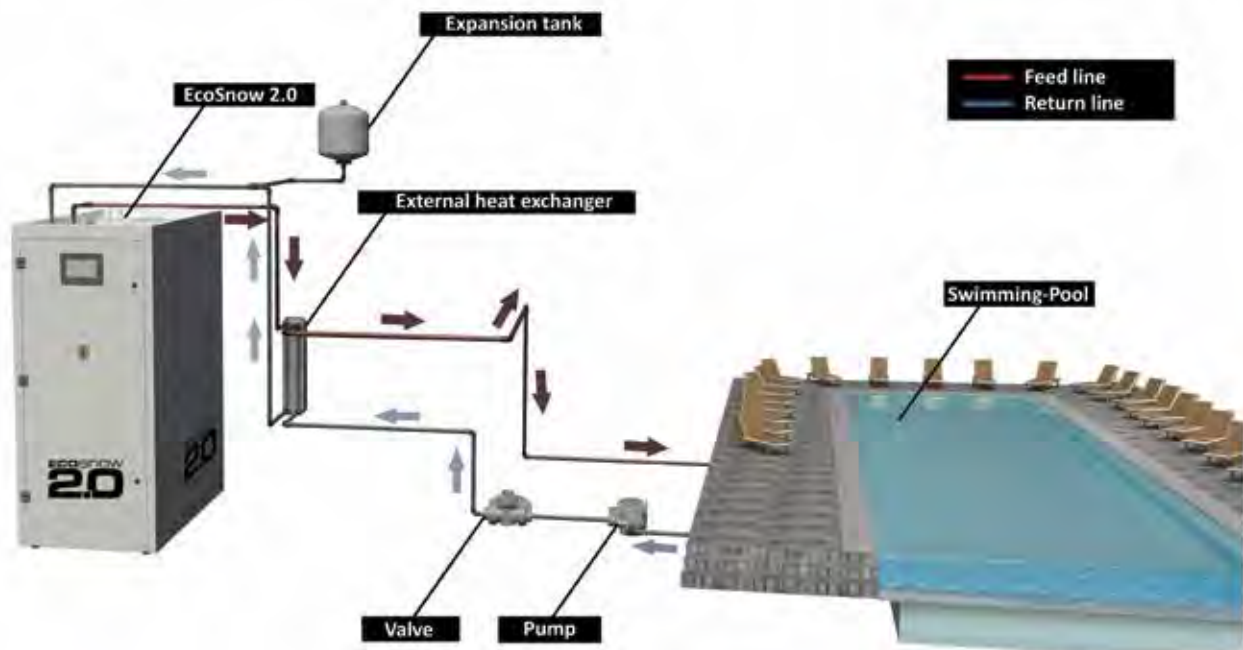

This diagram illustrates the symbiotic relationship between heat and cold in a modern spa. The water required for snowmaking comes from the pool and the heat generated by the snowmaking is funneled back into the swimming pool.

Lighting and Audio/Visual

Integrating lighting into thermal cabin ceilings can be done with a great many designs and materials, but the presence of high levels of heat and moisture creates certain limitations, so it is vital that any proposed 'standard' fittings being considered are tested for such applications. The advancement of fibre optics and submersible LED lighting has opened up a great many more creative opportunities for these cabins. The main points to consider are the future accessibility of light sources for maintenance and replacement, it should be remembered that LEDs don't last forever, so continuous LED strip lights will eventually have to be replaced. With the design community favouring indirect and concealed lighting, any recesses, particularly in 'wet' rooms, must be designed in such a way that condensing steam and humidity cannot build up in these recesses as such an event would cause electrical safety and health and hygiene issues.

Lighting and audio/visual add significantly to the ambience of hydrothermal cabins. Lighting for aesthetic purposes can be quite sophisticated and multi-dimensional, including changing colors and specialist effects. It's important to remember to provide lighting for cleaning and maintenance.

Similarly, music and sound effects are used to create the required ambience. This means the provision of a programmable MP3 player/controller is required, together with waterproof speakers, resistant against both humidity and corrosion.

Newer developments in audio/visual include TV installations with specialist waterproof monitors and other broadcasting components.



State-of-the-art saunas, like the S11 Sauna from KLAFS designed by Studio F.A. Porsche, offer audio and visual programs to alter the entire sauna bathing experience., giving users the unique ability to choose a specific program based on the results they desire.

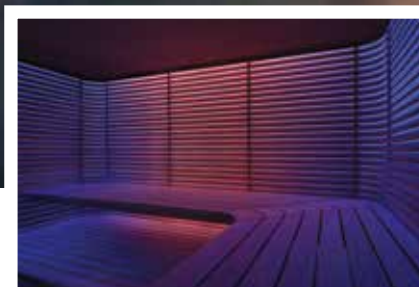



An example of a “loft” style ceiling.



A flat ceiling in a steam room can work perfectly well as long as it is correctly designed, insulated and finished.

Ceiling Design and Construction

There is frequent debate and discussion on the topic of ceiling design in thermal cabins due to their unique environment.

Some of the common questions raised, include: What is the ideal height for thermal cabin ceilings?

The simple answer is “as low as possible.” Ceilings should be no more than 20 cm (8”) above the head of an average height bather sitting on the highest level of benches. If a sauna or steam room bench is at 90 cm (approx. 3’) and the top of an average height person’s head is 90 cm (approx. 3’) above the bench, then the ideal cabin height is 210 cm (7’). Current trends lead architects and designers to want to create spaces with very high ceilings, but these trends are detrimental to the bathing experience of the guest.

The higher the room, the less efficient it is not only in warming the guest but also to operate as it will require far more energy to heat a large volume of unused space. It is true that traditional saunas were much higher structures, but in such structures the seats were frequently also at a high level, leading them to be described as “loft” or “gallery saunas,” where the seats are close to the eaves of a pitched roof cabin on a gallery that is built around the heater on a lower level. The exception to this ceiling height rule is a traditional hamam. Turkish hamams, in particular, have very large domed roofs pierced by ‘elephant eye’ glazed openings through which natural light streams. Hamams were traditionally heated by a hypocaust or underfloor heating system, so the warmth from the floors and horizontal seating surfaces radiated heat upwards. Early architecture didn’t consider the energy efficiency of the buildings. Today, this design style can be replicated but will also incorporate heat recovery technology to ‘recycle’ the heat from these voluminous domes while exhausting stale air.

Steam room ceilings often gather condensation: how can this be minimized?

The secret of this is to create a warm roof, so when hot steam comes into contact with the surface of the cabin roof or ceiling, it is not instantly cooled by a cold, smooth surface. So there are two critical factors here: the level of insulation on the ceiling is vital and the choice of material used to decorate or finish the ceiling is also important.

Guidelines for Ceiling Construction

Finish and Insulation	Ceiling Pitch/Style	Performance
Ceiling Type: Insulated building board at least 8 cm (3") thick		
Heavy textured render or sprayed on popcorn type texturing with waterproof paint finish	Flat	Well insulated; texturing prevents condensation adhering to the surface
Smooth render and waterproof paint	Pitched or curved as in a barrel vault, to avoid dripping, allowing droplets to run to the sides	Well insulated, but smooth surface will produce drips unless it is sloped or curved
Tiled with mosaics	Will drip regardless of the style/angle as the joints in the mosaics will form droplets that cannot run away, even on a sloped surface	Poor, not recommended
Tiled with large format tiles or stone	Less likely to drip than mosaics, but joints in the material mean drips will form, even on a pitched or barrel vault roof	Can work with good design and craftsmanship
Ceiling Type: Stud framework and various types of board cladding		
Difficult to reach levels of insulation necessary to construct a 'warm' roof. Typical U value for a thermal cabin ceiling is 0.39 which has an equivalent R value of 14.6	Must be sloped or barrel vault roof	Poor, not recommended. The materials typically used to clad 'drywall' type structures are rarely moisture resistant and not capable of forming a completely waterproof membrane between the board and the structure; runs the risk of mold formation, unpleasant odors, structural deterioration and possible collapse
Ceiling Type: Fiberglass (also known as GRP (glass reinforced plastic/polymer); FRP (fiber reinforced plastic/polymer) or FCP (fiberglass composite plastic/polymer)		
Normally smooth, with a pigmented gel coat or possibly even a fine acrylic membrane bonded to the surface to give decorative finish to resemble stone or granite. Must be insulated, with spray insulating foam of only 2.5 cm (1")	Requires a pitch because the typically low levels of insulation cause high levels of condensation	Useful if specific themed effects are required, but the need to make moulds to form the roof panels can be costly if customized; more common on 'standard' sized and symmetrically shaped rooms. U (or R value) is low, so can lack necessary warmth

Building Management Systems

Building Management Systems (BMS) allow control and monitoring of all the building services—including HVAC automation, energy control/consumption, access control, video surveillance, ventilation, security and fire protection—from a single point. In addition, they enable easier operation and maintenance of all functions of a building. In the case of hotel installations, a BMS may already be in place and it's often possible to adapt the BMS to the spa environment.

However, the best practice is to install a separate spa technology management system as a standalone system that works independently of a BMS and allows users to control and monitor temperature, lighting, music, etc., from a central screen at the reception desk; control panels should be in place throughout the spa to manage and maintain various equipment and functions. These control panels gather relevant signals and alerts, routing them back to the central unit. Warnings/alerts can be issued when a light bulb has gone out, temperatures are above or below normal, a therapist or guest has pushed a panic button, water ingress/leakage is occurring, etc.

It's important to note that there is a downside to remotely controlling thermal rooms and pool installations. If you take the need for physical checks out of these areas, there's a risk that problems in the system will go unrecognized/unseen. For example, there could be water leakage or even risk of fire that go unnoticed because no physical checks are being made.

There are standard rules and regulations (in fact, laws in many countries) that insist thermal cabins and pools be checked physically every six hours—in this case, the cabins are set to switch off every eight hours of operation, so that a physical check is guaranteed to be conducted and the experience turned back on. However, a BMS system can be programmed to override the physical check by simply turning the experience on remotely. To avoid this happening, a key switch or touch panel with a pin code should be positioned at the thermal room or pool itself, and it must be programmed not to re-start until a staff member has physically checked it.

Spa Management System Functionality

- Acoustic sound off/on (music and alarm)
- Acoustic volume control (music and alarm)
- Activation signal (e.g., panic button)
- Maintenance issue alerts (e.g., light outages; water leakage; low levels in dosing system; etc.)
- Equipment off/on
- Fan speeds/air extraction rates
- Fault signal/message
- Lighting-level adjustment
- Set/monitor timers
- Room-temperature monitoring and adjusting
- Water/steam-temperature monitoring and adjusting
- Service reminders
- Password protection and restricted access
- Remote control access via Internet connection



Smartphone apps puts the control of hydrothermal areas into the palm of your hand.

Courtesy of KLAFS

Connected Wellness

Another opportunity in today's spa builds, is putting technology in the palm of everyone's hand and allowing for "connected wellness." Wet treatment zones can be made more efficient while providing a better, more customize, level of experience for the user and increased safety and support in running a spa.

Both commercial and residential spas benefit from "connected wellness" in their wet treatment and showering areas—giving guests the ability to manage lighting, sounds and scents at the touch of a finger. For this to be effective, all product solutions must have a standardized interface (e.g. KNX, IP, DALI, etc.) to enable communicating with each other and, in the case of a commercial build, will require a server to run them.

With "connected wellness," rooms can be prepped and customized with the touch of a finger, welcoming guests with their favorite scents, light atmosphere and relaxing sounds and a warmed up shower.

Connected solutions can be controlled remotely and send status information to a main desk, so that spa staff is instantly informed when certain treatments/ experiences are in use and can alert staff to any issues.

The "Smart" Spa

Today, there is a plethora of smart devices and apps available for controlling every aspect of a residential or commercial spa—including temperature, lighting, aromatherapy, audio options and more. In order to explain the various systems, we've separated out residential and commercial options but smaller hotels, spas, health clubs and wellness centers will also want to consider exploring systems designed primarily for use in the home.

Connected Wellness at Home

Just as more and more people are adopting smart devices in their homes to control appliances, lighting, temperature, music, security cameras and the like, it's become more common to use a smartphone and an app to control home wellness equipment.

Given how far this technology has come, there is almost nothing that can't be remotely controlled by the homeowner—so as long as the home is equipped with a robust networking systems, either Wi-Fi or hardwired, the sky's the limit. However, it's important to be aware of the potential safety and even ecological concerns that come into play when remotely controlling temperatures and operating times in these specialist rooms.

For example, a home sauna with a smart controller should also be fitted with a door contact switch so that the app can verify that the door is closed before activating the heater. The app will enable the homeowner to pre-select an operating temperature and to turn the sauna on at a given time and for a fixed duration. If the sauna has multiple functions, such as a Soft Sauna, then these can also be selected from the app.

Lights and music selections can also be controlled if the operating system has been fitted with this function and some of the today's equipment supports voice commands via Alexa or other similar technology.

Commercial Connected Wellness

While it's certainly possible to also employ a wireless system in a commercial spa, the preference is to incorporate hardwired networking into a public spa area. The reasons are two-fold: first, there are well-documented concerns that long-term exposure to Wi-Fi signals and the associated electromagnetic frequencies from the devices they support—routers, phones and other smart device—could be harmful to our health (something that might also prompt homeowners to opt for hardwire solutions). Health questions alone are likely a big enough deterrent to placing wifi equipment in a building designed for improving wellbeing, but, practically speaking, hardwiring makes much more sense in a space where there are a multitude of small rooms and corridors that are not conducive to good Wi-Fi communication.

When choosing a spa technology management system that works independently of a traditional BMS, operators will gain increased functionality and flexibility because standard BMS systems don't often support the wide range of spa equipment and interfaces currently available.

Of course, the network cabling that runs each piece of equipment will need to be taken into account in the planning stages of the spa. After installation, the spa management system will allow different user levels to be set, so, for example, a screen at the reception desk could keep staff informed of all operating temperatures, start/stop times, dosing system levels and guest alarm activation, but access to the equipment control, set up and diagnostics could be reserved for higher-level users.

Plant/Mechanical Rooms

One of the most common mistakes made in hydrothermal spa designs is the omission or poor planning of the size and location of the plant/ mechanical room. And, of course, without the mechanics/equipment that runs the thermal and pool areas, they simply won't operate. This means much consideration should be given to the location and size of the plant rooms during the building design stage.

Expert input is necessary to understand plant/ mechanical requirements of the various hydrothermal areas. In simple terms, a heated swimming pool will have a larger plant room than a salt cave, while a sauna or steam room's mechanics can either be located on the outside of the cabin, or in a plant room located a short distance from the cabin. All should be discreetly accessible by qualified personnel at all times.

Plant rooms have two important functions:

1. They house the major water, electrical and HVAC systems that support the thermal room or pool.
2. They offer access to equipment, e.g., dosing systems that require replenishment and maintenance, along with the major water, electrical, HVAC installations that support the entire installation.



Example of a small plant room for maintaining a hot tub or spa pool.



Chapter Nine

Health, Safety & Hygiene

Consideration for the health and wellbeing of users begins when a spa is in its earliest design stages. Whether building a residential or commercial spa facility, it's important to take into account the factors that affect the wellbeing, either directly or indirectly, of the people using the thermal cabins and pools.

A calm and confident front desk is the result of a well thought out hydrothermal build that not only appears inviting but also operates so smoothly that guests are unaware of anything going on behind the scenes.

The “health” of any building—regardless of usage—is something designers/architects have been becoming more and more aware of in recent years. In the case of hydrothermal builds, the most important health and safety factors are governed by the successful implementation of these core elements: heating, ventilation, air conditioning, building materials and cleaning agents.

By their very nature, hydrothermal areas, with their extensive use of heat and moisture, are ideal environments for the growth of fungus and mold—something that can be controlled during the design and building process and maintained through proper maintenance and cleaning. In addition, the high levels of moisture make the surfaces (floors and benches) incredibly conducive to slipping—another factor that is easily mitigated by using the correct materials.

The high, ambient temperatures used throughout the building to keep wet and minimally clothed bathers comfortable means that waterborne fungus and mold isn't only an issue in the thermal cabins and pool areas—they can also surface in other communal and relaxation spaces.

In Design

Increasingly, more and more spa designers, owners and operators are actively engaged in the promotion and development of healthy buildings. They understand that it's important to be able to deliver the benefits of health and wellness treatments/experiences in a building that is specifically designed to be “healthy and well.”

In the broadest sense, a “healthy building” is designed with the goal of reducing any negative impact it might have on occupants and the environment. That means using building materials and best practices that minimize risk to a person's health—whether that be through illness or accident.

During the design phase, it's imperative to consider and analyze the materials that will be used and to understand how they will withstand the effects of steam, sweat, oils and cleaning water/agents.

In thermal rooms and communal spaces, it's important to choose surfaces (benches, floors, walls) with minimal joints, thus avoiding the need for excess grouting. This makes cleaning and disinfecting easier, and, ultimately, longer lasting and requiring less maintenance. Additionally, specialist building materials, such as mortar-coated, expanded, polystyrene hard foam, make it possible to clad walls, floors, steps, benches and shelves in ways that are completely waterproof and mold-resistant. For example, in contrast to plasterboard, hard-foam polystyrene has been proven to prevent the formation of mold due to its alkaline properties. So usage of this humidity-resistant building board will minimize the risk of infection or allergies because it doesn't provide a suitable breeding ground for microscopic organisms or germs.



Courtesy of Sommerhuber

When designing all aspects of the spa, consider minimal joints and grouting. This not only makes cleaning and disinfecting easier, but are also longer lasting.

Loungers finished with large-area heat storage ceramics are easy for cleaning and maintenance.



Courtesy of Sommerhuber

Proper drainage planning is also imperative, as it plays a major role in the health of a hydrothermal building. All excess water used during treatments and in cabins and pools must have somewhere to go. Correct drainage keeps bacteria from breeding and also minimizes the slip risks caused by wet and dirty floors. (Not surprisingly, slipping and falling is the most common accident that can occur in a spa area).

Ventilation also plays a key factor in the health of the building and the health of those in it. In addition to the ventilation requirements outlined in Chapter 8, it is essential to ensure smooth, not flexible, exhaust ducts are installed and that they fall in the direction of a drain point(s). This is imperative to avoid any pooling or lying of water in the ducting, preventing the incubation of legionella bacteria, the exposure to which can cause potentially fatal pneumonia. In cabins that are highly affected by heat, water and humidity, there should be a ventilated cavity between the room walls (or cladding) and the building walls.

Of course, cleaning and maintenance play a key role in minimizing health risks in any building. Wet and humid areas are difficult to clean and maintain at the best of times—in any building, the bathroom is the most susceptible to fungus and mold. This makes it vitally important to design the building/space while having the perspective of the person(s) who will clean it in mind. For example, consider creating rounded versus square corners for easier cleaning and always use sloped surfaces to avoid unhygienic pools of water on seats and other flat surfaces. Make sure there is an easy path for water and cleaning solutions to reach the drainage in the floor.

Emergency call systems, like those found in the healthcare industry, should be included in the design phase. These systems will alert staff to incidents or accidents, and, because all areas of a hydrothermal spa have associated risks, these systems should not only be adopted in the most “at risk” spaces (such as the thermal cabins and pool areas) but throughout the facility.

Key Design Considerations for Health/Safety/Hygiene:

- Proper drainage to avoid excess water that can cause slips and/or breed bacteria
- Ventilation that enables the proper flow of oxygen and condensation
- Emergency call systems
- Measures for easy cleaning and disinfecting of all areas
- Building materials that minimize the growth of mold and bacteria

In Construction

Of course, the goal is that most risks are eliminated during the design stage. However, no matter how focused designers and architects are on these points, the construction phase is often where even the most conscientious professionals can see radical changes to their original specification. This is the phase where things like “value engineering” can seep in and some of the specified materials, equipment and services are modified or even omitted to save money.

Often, during the design phase, clients are unwilling to agree to specified, branded products in tender documents and/or drawings. This means design intent can give way to financial pressure during the actual build. Product substitution is a frequent practice in the construction industry, and, though designers will reference a particular product or manufacturer, contracts will often carry the clause to allow for “or equal and approved” products. This invites contractors to offer financial incentives by providing products



Common Mistakes in Hydrothermal Builds

- Emergency call buttons in wet areas are designed to withstand heat and water. A wet area specialist will install them in thermal cabins and pool areas but they are not responsible for the entire call system which must be integrated by an M & E consultant.
- Leading with design and not considering safety/health
- Not allowing for disabled access and installing as an afterthought
- Forgetting slip-resistant flooring for wet area floors and multi-tier seating
- Cleaning tiled areas with pressure washers that end up blowing grout from the joints, creating bacteria and mold traps
- Not using heat resistant materials for handles in saunas
- Not ensuring that all doors to thermal cabins open out and have non-mechanical latching systems or heavy self-closing devices
- Incorrect ventilation causing poor air quality and/or condensation in ducting
- Failure to consider installing automatic water sanitizing and automatic disinfection of popular wellness experiences, like foot spas and Kneipp walks, after used by a guest
- Failing to use sterile salt/brine solution in nebulising inhalation systems
- Use of low quality aroma products in emulsion carriers instead of essential oils (chemical based aromas are often sold without Material Safety Data Sheets (MSDS) and could expose an operator to potential claims
- Not installing backflow prevention valves in experience showers and other features in which aromas are injected to water flowing from the main circulation system will risk polluting the whole water supply serving the property

they feel are more competitively priced but often don't offer the same quality. And, of course, budget constraints means these "alternative" products are frequently accepted because they provide significant short-term cost reductions.

Of course, this short-term financial gain can lead to the construction of substandard hydrothermal areas that quickly fall foul of health, safety and hygiene standards after construction.

In Operation

"Don't expect what you don't inspect!" is the best advice for spa operators. A clean and healthy environment in which guests can enjoy the facilities is the responsibility of the spa manager—whose job is to supervise the staff and ensure vital duties are performed at all levels.

Operational Tips

Ventilation and Air Exchange

- Air in saunas and steam rooms should be refreshed/exchanged six times an hour
- Instruct staff to keep doors ajar at the close of business to increase ventilation and assist in drying the rooms
- Consider adding a portable UVC air sanitizer to your hydrothermal hygiene toolkit

Follow Best Practices

- Post clear instructions of hygiene requirements (such as showering before entering any thermal room).

Wet Area Hygiene

Hygiene is important at every level of a spa—from pool water treatment and the correct design of ventilation ducts to the effective daily cleaning of floors and the deep cleaning of body fat residues from steam baths. This has a direct impact on the health and safety of the spa.

Major Health, Safety and Hygiene Risks

- Accidental slipping due to poorly specified, cleaned or badly drained surfaces
- Bacterial cross-contamination from user to user
- Fatal waterborne illnesses, such as legionella
- Numerous illnesses, such as ear infections and viral conditions, transferred via poor pool water treatment and sanitizing

There are specially designed acidic cleaning solutions for tiles, fittings and accessories that will dissolve lime deposits and grease scum gently, while specialized pipeline disinfectants attack waterborne germs and fungus their its source.

- Use recommended, high-quality consumables (aromatherapy, salts, body oils) to avoid damage to equipment/materials and to ensure scents are all natural.
- Hydrothermal equipment requires high-quality, potable water. Poor quality water can damage equipment, increase maintenance frequency and create a negative user experience, so consider water softeners and filters as essential items.

Monitor All Areas

- Monitor steam rooms, saunas, etc. to ensure they are set to the correct temperatures and humidity levels.
- In addition to having a central Building Management System, thermal cabins and pools should be physically checked at regular intervals (typically every hour).
- An on-going routine maintenance program must be in place in accordance with equipment manufacturer's instructions to minimize hazards and ensure bather safety.

Cleaning Tips

General Protection and Tools

Provide inhalation masks, protective glasses or full-face visors and gloves as standard protection when handling chemical cleaners; use small brushes to ensure all corners and niches are cleaned. In addition, consider adding a portable UVC air sanitizer to your hydrothermal hygiene toolkit.

Cleaning a Steam Room, Hamam or Other Tiled Room

The truth is, cleaning a steam room, hamam or other tiled room, is really as simple as cleaning a bathroom. Regular soap and water will clean the surfaces and even wash germs away and cut down their quantity; but, to actually kill germs, you must sanitize or disinfect all surfaces after cleaning them. The best way to do this is to follow the CDC's recommendations to use cleaning products with at least 70% isopropyl alcohol.



Courtesy of Sommerhuber

A clean and healthy environment in which guests can enjoy the facilities is the responsibility of the spa manager—whose job is to supervise the staff and ensure vital duties are performed at all levels.

Cleaning a Sauna

Disinfecting a sauna is similar to a steam room: first clean the surfaces with soapy water and then clean the benches with 3% hydrogen peroxide straight from the bottle.

Avoid Commercial Steam Cleaners

If you're planning on a deep clean, avoid commercial steam cleaners or pressure washers because they can damage tile grout and remove the wood's natural protective surface. Instead, opt for a domestic-quality, low pressure steam cleaner as an excellent way to remove excess, residual dirt and body oils before any of the above cleaning processes are undertaken.

Disabled Access in Hydrothermal Areas

In addition to being aware of a hydrothermal area's potential health and safety risks to all visitors, it's also important to consider specific access issues for disabled individuals. In many countries, planning access for the physically disabled is the law, however, regardless of legalities, it's also a positive sign of inclusiveness and enables a facility to serve a broader number of people. And, of course, individuals with motor or physical disabilities will greatly benefit from hydrothermal treatments.

Though each country will have its own specific codes and rules prohibiting discrimination against people with disabilities, it's the Americans with Disabilities Act (ADA) that has made the greatest impact on hydrothermal builds. In particular, the state of Florida published its own interpretation of the ADA in 2012 that has a direct impact on the construction of thermal cabin builds and, it's worth noting that the addendum to the ADA is gaining widespread adoption not only in the US, but wherever US operators build in the world. The code specifically covers wheelchair access to saunas and steam rooms and all derivatives of these cabins (including hamams, tepidariums, etc.).

Key Aspects of the ADA Code for Buildings

- Each cabin requires a dedicated wheelchair parking space that measures at least 760 mm wide x 1220 mm deep (30" wide x 48" deep)
- Wheelchair parking must be located at the end of a bench and parallel to the short axis
- A bench of at least 1065 mm (42") wide and between 510 mm to 610 mm (1' 8" x 2') deep must be kept clear immediately adjacent to the wheelchair parking space
- The bench needs to be between 430 mm to 455 mm (17" to 19") above the floor
- If the bench is not against a wall, it must have a backrest at least 455 mm (18") high
- Benches must have slip resistant finishes

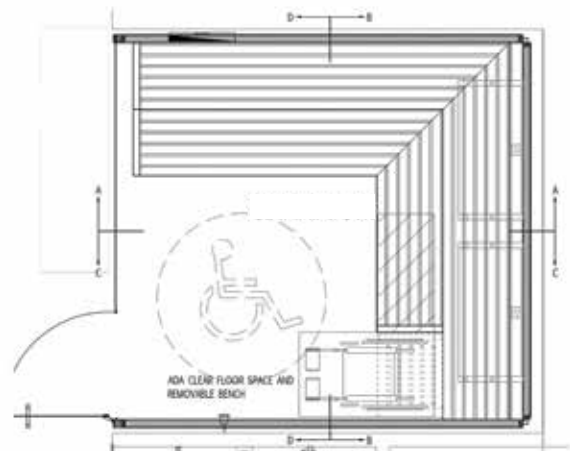

Illustration of a sauna providing correct wheelchair access and parking.

Note: Non-permanent furniture elements can be located in the wheelchair parking spaces, so, for example, a sauna can be designed with a removable or retractable bench section that will provide the correct size parking space when removed/retracted.

Other general disabled access features to keep in mind when designing and building a hydrothermal area:

- Entry ramps
- Correct door widths
- Correct clearances on the pull and push side of doors
- Low-level emergency button inside the room for assisted exit
- Low-level bell at entrance to request assisted entry
- Disabled bathroom
- Accessible changing and locker rooms, shower area
- Treatment rooms on the ground floor and/or lifts to upper floors
- Wheelchair access to treatment rooms (corridors, doors, and turning radius)
- Hydraulic treatment tables for easy access

Disabled Access in Pool Areas

If the hydrothermal area has swimming facilities, they should be designed to be fully accessible to individuals with disabilities. There are four different ways to approach this, depending on the build:

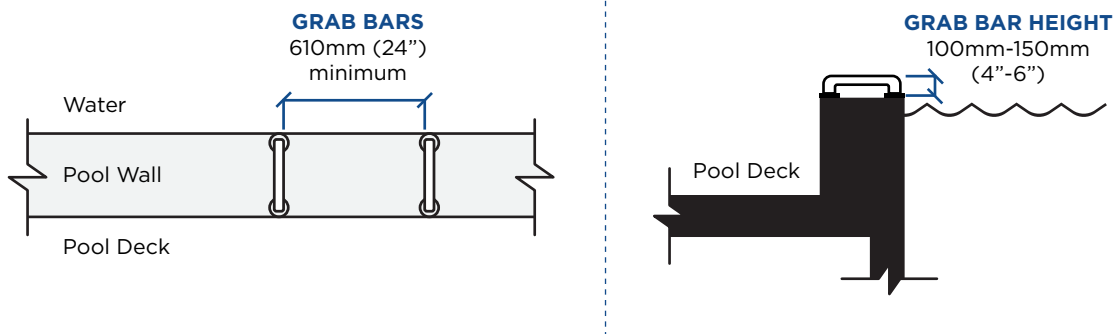

1: ADA Transfer Wall

A solution that caters to those with sufficient upper body strength to transition from wheelchair to pool independently. This feature must meet height and width specifications to accommodate users safely.

- At least one grab bar should be provided on the transfer wall. Grab bars should be perpendicular to the pool wall and extend the full depth of the transfer wall. Where two grab bars are provided, clearance between grab bars should be 610 mm (24") minimum (see illustration above).
- The height of the transfer wall should be 405 mm (16") minimum and 485 mm (19") maximum measured from the deck.

2: ADA Transfer Steps

Intended for guests who require stability as they move from their wheelchair into the pool. Each step is designed with handrails for a secure transfer.

Transfer step height should be 205 mm (8") maximum. The surface of the bottom tread should extend to a water depth of 455 mm (18") minimum below the stationary water level. Where possible, the height of the transfer step should be minimized to decrease the distance an individual is required to lift up or move down to gain access.

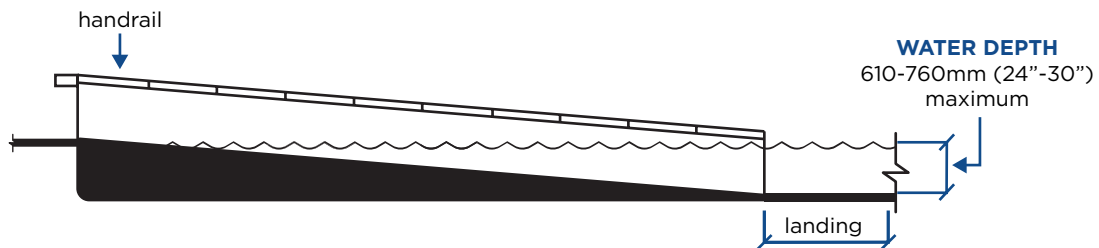
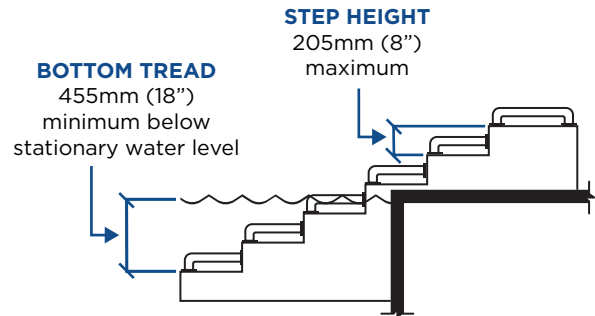

3: ADA Sloped Entry

A seamless entry alternative that provides an unobstructed, gradual pathway into the pool. This option accommodates individuals using wheelchairs as well as those who prefer a walk-in approach, with or without assistance.

A sloped entry must have a maximum of a 1:12 slope ratio. In other words, a pool that is 122 cm (4') deep would require a 14.6 m (48') long ramp. Ideally, the slope should extend into a water depth between 610 mm to 760 mm (24" to 30"). The sloped entry must be a minimum of 915 mm (36") wide and have handrails on both sides.

4: ADA Pool Hoist

Swimming pool hoists (or lifts) are mechanical devices that are used to transfer an individual in and out of a pool. They come in different shapes and sizes and can be battery powered or powered by water pressure. A hoist is the most versatile and common solution.

Figure A: 405mm to 485mm (16" to 19") from the deck to the top of the seat.

Figure B: Seat submerges 455mm (18") below water line.

Figure A

TOP OF SEAT
405-485mm
(16"-19")
to Pool Deck

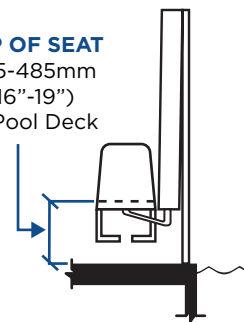
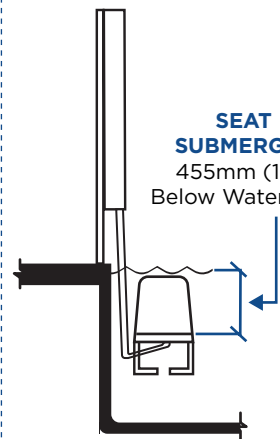

Figure B

SEAT SUBMERGES
455mm (18")
Below Water Line



Pool Water Safety

Pool staff should be trained to conduct regular testing of the pool water. Below are testing guidelines:

Daily Tests (Every 2-3 Hours)	Water Quality Values
Free Chlorine	Range 0.5 to 3.0 mg/l (Aim for 1.0 to 2.0 mg/l)
Combined Chlorine	Not more than one third of total chlorine
pH	Range 7.2 to max. 7.6 (Aim for 7.2 to 7.4)
Weekly Tests	Water Quality Values
Alkalinity	100 ppm to 180 ppm Sodium Hypochlorite 100 ppm to 120 ppm Calcium Hypochlorite
Calcium Hardness	200 ppm to 1000 ppm (not less than 200 ppm)
TDS	Total Dissolved Solids Max. 1000 ppm above source water
Pool Balance	Refer to Langelier Saturation Index

Pool Chemical Room Safety

Careful consideration has to be given for safe delivery of chemicals, including offloading and transfer within the building, avoiding stairs where possible.

Storage: Adequate, separate storage and containment space must be provided for the chemical containers and bags required for the normal daily and weekly refilling of the operational chemical day tanks.

Containment Bunds: A chemical bund area should be constructed in concrete with a cement render internally and finished with a chemical-resistant (or fiberglass-lined) material, providing a fully contained bund capable of holding 110% of the maximum chemical volume.

Segregation: Separate enclosures should be maintained for all potentially hazardous chemicals (acids and alkalis) in separately ventilated rooms, with a minimum of four air changes per hour.

Drench Showers/Eyewashes: Emergency drench showers/eyewashes are recommended in commercial chemical rooms.

Eyewash: A sealed sterile type of eyewash bottle should be located near the intake point and in the chemical stores

Sink: A large sink with hot and cold running water is required for cleaning the chemical injectors.

Risk Assessment

In any business, there is the potential that a staff member or client can be injured or become ill as a result of an incident occurring in the workplace. This is why, whether it's a legal requirement or not, operators should carry out risk assessments on all aspects of their spas. Everything considered a potential risk should be fully documented. Further safeguards to assist operators in refuting or diminishing any claims that may occur: keeping thorough cleaning and maintenance records, as well as customer-usage numbers and chemical applications.

A risk assessment looks at the steps to be taken to eliminate and control risk and examines every possible “what if” scenario.

Risk Assessment Should Include the Following

- Identification of all hazards (such as slippage, waterborne illnesses, chemical imbalances, etc.)
- Evaluation of the associated risks
- Consideration of the severity of the consequences and chances of it occurring
- Identification of all persons (including staff, contractors, guests) at risk
- Establish control measures to prevent risks
- Ensure staff and guests are aware of any potential risks and symptoms
- Identify specific legal duty or requirement relating to the risk

Control Measures to Consider

Thermal Areas

- Display clear instructions in prominent positions explaining how equipment should be used
- Minimize/eliminate potential for scalding or burning
- Ensure proper ventilation and drainage
- Conduct and document regular cleanings and checks—hourly, daily, weekly, monthly, yearly
- Test alarm systems regularly
- Always provide a supply of drinking water for guests and staff

Pool Areas

- Display clear instructions about safe usage
- Follow a daily, weekly, monthly and yearly cleaning and maintenance routine
- Regularly test waters for disinfectant, pH levels and clarity
- Check filters and backwash as advised
- Drain and clean system as advised
- Ensure plant room and chemical storage area is well-ventilated
- Clearly label and store chemicals away from each other
- Follow applicable legal legislation for handling of chemicals



Chapter Ten

Sustainability & Regenerative Design

Where “green design” and sustainability have dominated the last two decades of the building industry, today’s experts are adopting concepts of regenerative design and wellness architecture—practices that move away from doing “less harm” and focus on symbiotic relationships to the local ecology while enhancing all dimensions of wellness in order that both humans and the planet thrive.

This chapter was originally written in collaboration with Veronica Schreibeis Smith, Chair of the Global Wellness Institute’s Wellness Architecture Initiative.

Spas by their very nature are inherently focused on not just sustaining guests’ health and wellbeing, but enhancing overall wellness to help people live longer, more vibrant and more fulfilling lives. The architecture that houses spas should do the same by not just delivering sustainable, but regenerative environmental solutions, and integrating wellness strategies that deliver experiences with meaningful impact.

Many spas embrace environmentally friendly design by closely scrutinizing the products they offer; reducing single-use supplies with durable beverage cups, cloth hand towels or microfiber body wraps; and simply asking clients to reduce the time spent in showers and to reduce the number of towels they use.

Of course, there’s much more spas can do to positively affect the world in which we live. Sustainability is a beneficial subset of regenerative design and wellness architecture, which is best

Sustainability means thinking about alternative sources of power, such as solar and wind power.

considered early in the planning and building stages of a hydrothermal spa area. These practices are not only good for the environment, they also enhance outcomes, are good for the reputation of the industry as a whole, and, last but not least, will have a positive impact on the profitability of your spa.

Sustainability and “going green” have evolved from being passing trends into more of a long-term commitment to regenerative design and wellness architecture—the practices of making choices that have a positive impact on both people and the planet.

Sustainable & Healthy Material Selection

Designing a wet area from the ground up provides the opportunity to think about integrating sustainable and regenerative strategies into every aspect of a hydrothermal spa. There are numerous ways to bring wellness into the build—including conscious consideration of the building materials and products being used to construct the cabins and pools.

To minimize the impact on the environment, many providers and manufacturers within the hydrothermal industry have adopted “green” practices, including reducing the amount of emissions that are released into the atmosphere, using less raw materials, recycling waste material and extending the durability of their products. This last point is important, because, although the expense of sustainable and eco-friendly solutions is often greater at the offset, in the long run, costs are typically much less.

However environmental considerations are only half of the selection process. How a material or product impacts human and planetary health over the course of its existence is the other half. Wellness strategies, for example, consider the elimination of toxins and pollutants, favor natural materials over synthetic ones, utilize nudge psychology and design to influence guest behavior, and intentionally enhance the local ecology, economy, and culture.

Comparing Insulation Value of Common Building Materials

The lower the U-Value, the more optimal the insulation properties of the material; conversely, the higher the R-Value, the more optimal the Insulation properties.

Wall Material	Thickness (MM)	U-Value (Low Value=Good)	R-Value* (High Value=Good)
Insulated Dry Wall	150	0.35	16.23
Concrete Blocks	200	0.39	14.6
Brick Wall	200	0.41	13.9
Poured Concrete	250	0.55	10.33
Hard Foam Building Board	50	0.59	9.6
Natural Wood/Rock/Sheep/Mineral Wool	50	0.59	9.6

**R-Value is measurement used in USA*

The first step is to research the provenance of the materials and products that you are using to verify they adhere to the environmental and wellness ethos of your hydrothermal spa. For example, look at the woods chosen to build the sauna and/or banya—are they being sourced sustainably from managed forests? Are the tiles made of sustainable materials, and/or do the tile suppliers adopt eco-friendly practices throughout the manufacturing process? If you are sourcing an entire cabin, has it been designed and manufactured with wellness at its core?

Effective Insulation

Since heat is such a huge part of a hydrothermal spa— and with heat comes a drain on electrical and/or gas resources—it's imperative to pay close attention to insulation. Thermal insulation saves costs and energy by reducing the working hours of steam generators and heating; it also reduces the maintenance costs of this equipment. One of the most common (and, ultimately, most costly) mistakes a builder makes when constructing a thermal cabin is the use of materials that do not effectively hold heat



Common Mistakes in Sustainability & Regenerative Design

- Not willing to commit to a bigger initial investment for the savings to payoff in the long-term.
- Uncontrolled usage/consumption of water.
- Concrete is only a green material in its raw, base-component format, as all constituent parts are from the earth, but it is the production and transportation of concrete that causes all its green credentials to fall away.
- Building everything from scratch on site is not as green as the use of prefabricated structures, built in a factory with all waste materials harvested and disposed of ethically or recycled professionally. E.g., wood sawdust can be reused, wood offcuts can heat a sauna factory throughout the winter, expanded polystyrene offcuts are harvested in the factory and recycled into yogurt pots, etc.
- Just having “green” products is not enough for sustainability; owners and developers need to look at every element of spas from the ground up for human and planetary wellness.
- Water recycling is not just the job of infrastructure and utility providers—spas can do it to.
- Not harnessing air and heat energy used in the spa somewhere else—e.g., producing snow and ice creates a lot of heat; employ a heat exchanger to use that heat to add a few “free” degrees to the water being used for the vitality pool.
- When selecting materials, a sole focus on performance criteria without consideration for health concerns often leads to specifying toxic materials that off- gas and harm the environment.

or withstand moisture. Simply building a sauna or a steam room with materials that are being used throughout the rest of a building will result in rooms that are very costly to heat up—both in terms of cost to the environment and the actual monetary expense to an operator.

The insulation value—called “R-value” or “U-value,” depending on the country of origin—of materials being used is incredibly relevant. For example, common building materials, such as concrete blocks and plaster, have poor R-values and will suck up the heat before the cabin itself will heat up. A sauna using concrete blocks might take two hours to achieve the correct temperature, while a sauna of the same size constructed using specialized insulation techniques and hard foam boards, or even a natural fiber insulation board, will take just 20 minutes to get to temperature.

In a steam room, insulation is also important in water conservation—a properly insulated room will require less steam to be delivered to create the correct humidity levels.

Heat Recovery Systems

A heat recovery system, commonly referred to as a heat exchanger, recycles energy that is otherwise wasted. In a hydrothermal spa, heat exchange systems both conserve energy and save costs. Some examples:

- **Pool Water Heating:** Spas typically need to heat large quantities of water for hot tubs and pools. A heat recovery system can capture waste heat generated from other parts of the facility (like the excess heat generated from the HVAC system or the heat generated to power features like snow and ice) and redirect it to heat pool water. This reduces the amount of new energy required to maintain the desired pool temperatures.

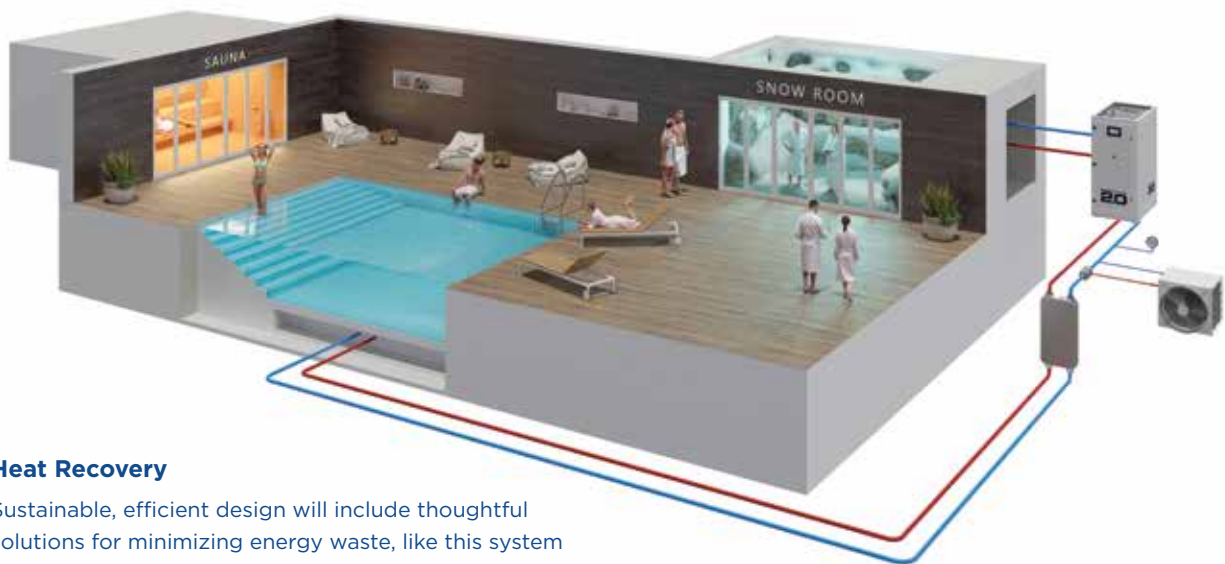

Heat Recovery

Sustainable, efficient design will include thoughtful solutions for minimizing energy waste, like this system that uses the heat generated to create snow to heat the pool water. See Chapter 9 for more discussion on heating and cooling services.

- **Air Heating and Cooling:** During cooler months, the heat generated from indoor hot tubs, steam rooms, or mechanical equipment can be redistributed to warm other areas within the spa. Conversely, during warmer periods, the system can help cool down rooms that tend to overheat.
- **Water from Showers and Baths:** Significant amounts of hot water are used in showers, baths, and other treatments. A heat recovery system can reclaim the heat from drained water to pre-warm fresh water entering water heaters or boilers. A drain water heat recovery system can capture the heat from hot water draining from showers, for instance, to preheat incoming cold water. This process can significantly reduce the energy needed to bring the new water up to a comfortable temperature.
- **Steam Rooms and Saunas:** Heat recovery can be particularly effective in areas generating a lot of steam and heat, such as steam rooms and saunas. Instead of letting the heat escape, it can be captured and repurposed to heat other spaces or water. For example, in a steam room, the steam that would typically ventilate out can be passed through a heat exchanger to reclaim some of its thermal energy, which could be used to warm up relaxation areas or heat water.

Water Conservation and Recycling

As water is such a huge part of wet area spa builds, a particular focus must be put on all areas being waterproof and watertight. One simple way to manage water waste is by installing sensors on faucets and showers so that water is never left running by guests or staff. Showers can also be programmed to shut off after a certain amount of time to minimize waste, and, of course, low-flow toilets should always be used.

When installing rain or drench experiences in a spa where water conservation is top of mind, consider these options:

- Set program times so that the spa operator controls length and the guest can't forget to shut the water off.
- Mist nozzles are an alternative cooling source to the water-consuming waterfalls, bucket showers or deluge jets. The gentle "misting" cooling effect is a very pleasant and water consumption is only 6 liters per minute while deluge showers frequently use 20 liters per minute.
- Recycling cooling shower water is most definitely the way forward and this technology is being developed.
- Reduced flow rate shower technology is constantly improving and worth considering.

If pools are included in a spa build, be sure to use materials that are proven to be the most effective at retaining water—such as stainless steel or composite GRP (fiberglass) versus cement. Water leakage is the biggest problem in pool builds but can be easily avoided by using the correct materials. In addition, minimizing water waste while the pool is in operation is important. A centrifugal pre-filter is a low cost piece of equipment that can be added to almost any pool system. The centrifugal pre-filter removes solids from the water by spinning it before sending it to a traditional sand filter, removing solids before they get trapped in the filter media. This can significantly reduce the backwash frequency of the pool system, thus saving water and minimizing the discharge of chemicalized water into the drain system.

Ecological Solutions

In combination with a central control system for the wellness area, the rooms that consume the most energy (sauna and steam rooms) can be controlled according to frequency of use. With the help of door switches, the performance/power consumption of sauna heaters and steam generators will be reduced when the door has not been opened for a certain period of time, something that can be customized to an individual operator's needs.

Alternatively, heaters and generators can be switched- off or reduced in power consumption when a door is left open, so they stay warm, but not hot, returning to bathing temperature quickly when the door is opened.

When designing mechanical and electrical systems, first consider reducing loads, second integrate climate-appropriate passive strategies, and then turn to renewable energy sources—such as solar or wind power—for generating electricity to run a hydrothermal spa where possible. There are many affordable ways to utilize alternative energy sources, such as solar power, by integrating solar roof panels to heat water for the pools and showers. Ground source heat pumps, which harness natural ground heat

Saving Energy

Energy consumption in thermal rooms varies greatly according to the method of construction and the selected finishes. The denser the material, the more energy it will take to heat the structure, rather than the bathing atmosphere.

For example, a concrete room with 20 mm-thick (less than 1") granite finishes will take an enormous amount of thermal energy to heat the structure before the room can be at bathing temperature; in colder climates, this can take hours and cost a great deal of money to operate. Therefore, considering the thermal effectiveness of the building materials used is imperative.

The same consideration should be made for swimming pools, especially in colder climates where concrete shells can absorb enormous amounts of energy, while pools made from far thinner materials such as fiberglass or stainless steel can be insulated.

Some examples from a simple steam room (steam output is measured in kilograms per hour (kg/hr) or pounds per hour (lbs/hr) are shown below:

- Concrete with granite finish requires 1.2 kg/hr of steam, equal to 0.9 kW in electrical load
- Insulated, coated foam boards (or natural insulation when possible) with the same finish require 1.0 kg/hr of steam, equal to 0.75 kW in electrical load
- In simple terms, the energy used by a concrete/granite room will be 20% greater and, therefore, cost 20% more to run.
- Given that the average life of a steam room is at least 10 years and often a lot more, the low cost of "traditional" building materials at the outset may reduce the capital costs of the project, but the ongoing higher revenue costs of inefficient construction will last the life of the steam room and far outweigh the initial saving.

by pumping water through underground pipes, require less electrical energy and are an extremely sustainable and effective method for heating and cooling water. Tankless or on-demand water heaters, which heat water as needed versus a water heater that features a continuous heating source, are another option, but, because the water flow rate is not likely to meet the needs of guests in a large spa, these might be better to supplement other heating solutions. Remember, short pipe runs, where possible, and proper insulation will go a long way in reducing heat loads and energy. And, if there's an option to use an electricity or gas supplier that provides green-sourced energy, you can be "green" with minimal effort and outlay of cash.

Of course, making and supplying your own energy is, more often than not, cost-prohibitive. In this case, it's important to focus on other ways to save on energy waste by using appliances that are rated energy efficient (e.g., the Energy Star rating). And, although people are becoming more conscious of energy conservation, relying on staff and guests to shut off lights when not in use is not enough; instead, consider installing sensors that will dim or shut lights off completely in unused areas of the spa.

A simple way to manage water waste is by installing similar sensors on faucets and showers so that water is never left running. Showers can also be programmed to shut off after a certain amount of time to minimize waste. Low-flow toilets should always be used; additionally, look to recover water wherever possible for reuse. For example, use all-natural, biodegradable soaps in the shower areas so the water is re-treatable and reusable.

If the hydrothermal spa is in an area that benefits from large amounts of rainwater, explore a rainwater-harvesting system that will collect and filter rainwater for use around the spa.

The Omega Center for Sustainable Living is a great example of a property focused on sustainability and regeneration and it was the first building in the United States to achieve both LEED® Platinum and Living Building Challenge™ certification.



In addition, getting the area's ventilation and climate control correct can pay huge dividends by reducing water and energy wastage. In the pool area, for example, your ventilation will help combat evaporation, a huge water waster. While in sauna and steam rooms, air extraction flaps/dampers that are controlled via your central control system will enable you to "fine-tune" the rooms' air extraction versus simple on/off switches, this can reduce the amount of energy used to maintain temperatures in these areas.

In addition, CO2 sensors that measure the air quality in saunas are another tool for minimizing energy waste. The more users there are in a sauna, the higher the CO2 content will be and, therefore, more ventilation will be required. This information can be used to increase or decrease the ventilation of a sauna.

Sourcing products for the hydrothermal area that are eco-friendly throughout their lifecycle minimizes waste in the long run. A good example of this can be found in today's choice of steam generators. Steam generators that are designed with eco-principles tend to cost more initially but can last up to 20 years versus a more affordable model that may last only three years. The implications on the environment are numerous. The cheaper unit will be sealed so repairs are impossible—which means it ultimately ends up in the landfill and a new unit must be purchased, while the more expensive steam generator allows for both repair and recycling.

Economic Advantages

The economic advantages to building a sustainable and eco-friendly hydrothermal spa are numerous. Up-front investments in sustainable designs and technology promise to deliver financial paybacks over the life of the building in the form of lower utility bills and reduced operating and maintenance costs. Regenerative design further increases these paybacks.

Additionally, wellness strategies don't just stop at the health impact for the guests, they take into account all aspects of a project's potential capital—financial and physical capital being the most commonly considered, while natural, social, and human capital are often forgotten. Evaluating how your project can maximize all five of these key areas will ensure long-term economic success.

Another less obvious, but equally important benefit is the goodwill created by these initiatives with both the local community and guests. Everyone wants to be part of an ethos that enhances both the health of the planet and human wellbeing. In short, integrating sustainable and regenerative environmental solutions with wellness strategies will create unique marketing opportunities for a hydrothermal spa.

Explore sustainable, regenerative, and wellness strategies with your team to save money in the long run!

Additional Resources for Sustainable and Regenerative Design

- **BREEAM: www.breeam.com**

The world's leading sustainability assessment method for master-planning projects, infrastructure and buildings.

- **Building Biology & Ecology: www.hbelc.org**

International organization providing principles and education focused on optimizing the built environment for human health.

- **Green Globe 21: www.greenglobe.com**

Certification for the sustainable operations and management of travel and tourism companies and their related supplier businesses.

- **Green Spa Network: www.greenspanetwork.org**

Sustainability assessments and easily adoptable practices for spas.

- **International Living Future Institute: www.living-future.org**

ILFI partners with local communities to create grounded and relevant solutions, including green building and infrastructure solutions on scales ranging from single room renovations to neighborhoods or whole cities.

- **LEED (Leadership in Energy & Environmental Design): www.usgbc.org/leed**

LEED certification is recognized across the globe as the premier mark of achievement in green building.

- **WELL Building Standards®: www.wellcertified.com**

The WELL Building Standard® is an evidence-based system for measuring, certifying and monitoring the performance of building features that impact health and well-being.

- **Whole Building Design Guide (WBDG): www.wbdg.org**

Provides government and industry practitioners with one-stop access to up-to-date information on a wide range of building-related guidance, criteria and technology from a 'whole buildings' perspective.

Vertical forests and living walls are part of the biophilic design trend which seeks to incorporate nature into design—a practice that not only minimize the stress of inhabitants, but also improves the air they breathe.



Glossary

Aromatherapy

The use of aromatic plant extracts and essential oils in massage, baths, showers and thermal cabins. (refer p. 23)

Aquapressure

Targeted water massage. Similar to acupuncture. (refer p. 94)

Aquathermal bathing (synonym “hydrothermal bathing”)

Pertaining to the temperature effects of water used in thermal cabins and pools. (Origin Greek)

Arctic ice Room

Operating at 5°C to 10°C (40°F to 50°F), these rooms provide contrast therapy to the hot rooms in a spa and mimic the traditional experience of a “roll in the snow.” (refer p. 98)

Balnea/Balneum

Smaller version of a Roman thermae (bathhouse) found in ancient Rome. (Origin Latin)

Balneotherapy

General term for water-based treatments using natural thermal, spring, mineral or seawater to induce relaxation, improve circulation, stimulate the immune system and bring about detoxification. (Origin Latin) (refer Chapter 7)

Banya/Banja

Term originally meant “bathhouse” in Russia but has been adopted to refer to the specific sauna-like room in a Russian bathhouse. (Origin Russia) (refer p. 63)

Biosauna (or Soft Sauna)

A gentler, less extreme version of a Finnish sauna operating at 50°C to 70°C (122°F to 158°F). (refer p. 64)

Caldarium/Caldaria

The hottest room in ancient Roman baths and a precursor to today’s steam bath. (Origin Latin)

Contrast Therapy

Refers to the therapeutic effects of hot and cold temperatures.

Deluge Shower

Delivers a huge dump of cold water on bathers so they can cool between heat treatments. (refer p. 90)

Experience Showers

Multi-sensory shower experiences incorporating smell, sound and visual effects. (Note: these are referred to as Rain & Drench Experiences in this edition.) (refer p. 90)

Finnish Sauna

A wood structure with a heat source (wood-burning, electric or gas); the hottest and driest room in any spa, running at 70°C to 90°C (158°F to 194°F) in US commercial facilities; 70°C to 105°C (158°F to 212°F), traditionally. (refer p. 56)

Floatation Pool

A warm bath containing oils or salts, where the guest floats on the water, usually in the dark or in subdued lighting. A floatation tank is bed-sized and is a closed environment, often in total darkness. (refer p. 138)

Foot Bath/Spa

Specifically designed for bathing feet in cool or warm water in between hot treatments; feet play an important role in the heating and cooling process of the body due to their small amount of flesh and fat. (refer p. 95)

Frigidarium/Frigidaria

The cold plunge pool in ancient Roman baths. (Origin Latin) (refer p. 137)

Furo

A private bathing ritual in Japan that takes place in a bath made of wood; the furo is often found in private homes. (Origin Japan)

Hamam

The word “hamam” literally translates to “bathroom” in Turkish and refers to the entire Turkish bathhouse. A Turkish hamam is a large domed structure with a central room (sıkaklek) in which the belly stone (göbek taşı) takes center stage. The belly stone is traditionally where attendants scrub and clean bathers. (Origin Turkish) (refer page 77)

Hammam

A Moroccan hammam is similar to a Turkish bath but has retained more of the traditional Roman bathing ritual—sending the bather on a journey through smaller chambers with varying temperatures (like the Roman journey through the laconium, caldarium, frigidarium and tepidarium). (Origin Moroccan/N. African) (refer page 77)

Hot Tub

Large tub or small pool of heated water used for hydrotherapy or pleasure. Some have jets for massage purposes. Hot tubs are sometimes known as spas or by the trade name Jacuzzi.

Hydrotherapy

The use of water for pain relief and treatment. The therapeutic effect of water depends on the temperature, depth and duration of immersion and its mineral content to soothe painful muscles and joints, as well as stimulate the circulation and immune system.

Hydrothermal Bathing

Pertaining to the temperature effects of water used in thermal cabins and pools.

Ice Bath

Operating at 10°C to 15°C (50°F to 60°F), these rooms provide contrast therapy to the hot rooms in a spa and mimic the traditional experience of a “roll in the snow.” (refer page 137)

Ice Fountain

An access of ice in a spa for bathers to cool their bodies between hot treatments.

Infrared Therapy

Using long-wave infrared radiation to distribute warmth through the peripheral nervous system. (refer p. 116)

Inhalation Room

Specific treatment room for inhaling agents to treat respiratory conditions such as asthma, bronchitis and emphysema. (refer p. 118)

Jacuzzi

Named after inventor and manufacturer, this is a bath or pool large enough for several persons sitting down to be massaged by underwater jets.

Kneipp Therapy

A 19th-century adaptation of hydrotherapy formulated by Pastor Sebastian Kneipp (1821-1897) and consisting of hot and cold-water treatments, walking barefoot in the morning dew, and the use of herbal bath oils, all combined with physical exercise and a diet of natural food. Popular in Austria, Germany and Switzerland. (refer p. 141)

Laconium

Name originates from Roman baths; this is a warm room where bathers can relax for long periods of time on benches or in individual, heated loungers or chairs. (Origin Latin) (refer p. 83)

Lap Pool

An exercise pool used for swimming lengths/laps. You can also find pools that offer both resistance and lap swimming in smaller spaces with the aid of motorized water-flow mechanisms. (refer p. 133)

Mineral Water

Water of natural purity used for bathing and/or drinking, the source of which has to be in a subterranean and protected water deposit. Mineral waters can have an acidic, basic or neutral pH, depending on the types of dissolved solids in the water. Depending on use, the content of some substances must not exceed the indicated limits. (refer Chapter 7)

Mud Bathing

Mud bathing originated thousands of years ago as a medicinal and beautifying ritual. The body is coated with organic thermal mud, and, depending on the minerals inherent in the mud, they can cleanse, exfoliate, absorb toxins, increase circulation and soften the skin. (refer p. 117)

Onsen

This pool type originates from Japan and has a significant role in the country's ritual bathing practices. "Onsen" translates as "hot springs" in Japanese and has come to refer to the natural spring baths found throughout Japan. Their benefits are closely dependent on the mineral properties and content of the water itself and typically include the easing of neuralgia, alleviation of muscle pain, the reduction of the symptoms of chronic skin disease and the relief of chronic fatigue and stress. (Origin Japan) (refer p. 136)

Pestemal

A pestemal (pesh-te-mahl) is the authentic Turkish bath towel. It is flat-woven with hand-tied fringe, typically made of Turkish cotton, linen or even silk. It is also known as a hamam towel, as it is an essential element of the legendary Turkish bath experience. Pestemals come in countless designs, textures, weights and colors. The hand-towel version of the pestemal is called a peskir (pesh-kir).

Plunge Pool

A cold plunge pool, also traditionally known as a frigidarium, is a cold-water pool that is typically entered after and between hot thermal treatments to cool bathers down. (refer p. 137)

Psammo therapy (sand bath)

Initially used in Ancient Egypt, sand baths are becoming popular in spas for their ability to help bathers relax both mentally and physically.

Rain/Drench Experience

Several shower options are available: cold waterfalls, mists, body jets and dramatic "experience showers" offering multi-sensory experiences that incorporate smells, sound and visual effects. (refer p. 90)

Refugium

The refugium is a relaxation area in a spa, typically smaller and more intimate than the tepidarium, and used for rest and sleeping.

Respiratory Therapy

The goal of respiratory therapy (also called inhalation therapy) is to improve respiration by steam inhalation combined with essential oils. There are specific treatments targeted at chronic conditions such as asthma, bronchitis and emphysema.

Salt Room/Cave

Salt therapy originated in Europe with natural salt caves and caverns. Claimed to relieve asthma, improve circulation and lower blood pressure, salt rooms and caves are specific treatment rooms requiring dry conditions, good ventilation and copious amounts of salt on the floor, walls and ceiling. (refer p. 114)

Sauna

There are several different styles of saunas in use today. The traditional and most common are Finnish saunas and Russian banyas; others include soft saunas (biosauna) and hybrid saunas. While various sauna types all run at slightly different temperatures and humidity, they are closely related in style, usage and health benefits. (refer p. 55)

Sento

The Japanese developed a form of steam bath called the sento, a type of vapor bath that uses aromatherapy elements and includes body scrubbing. (Origin Japan)

Snow Room

Cold rooms that use modern techniques to create real snow with which to cool the body. Operating at -10°C to 0°C (14°F to 32°F), these rooms are becoming increasingly common in modern spas. (refer p. 10)

Spa Suite

A bedroom suite that offers additional spa equipment, such as a hot tub, treatment table, experience shower, etc. (refer p. 112)

Steam Room/Bath

The modern steam room is unique in that it reaches 100% relative humidity—which gives it the element of steam/fog. The caldarium is the Roman precursor to the steam bath. (refer p. 69)

Steam Shower

A steam shower is a type of bathing where a humidifying steam generator produces water vapor that is dispersed around a person's body. A steam shower is essentially a small steam room that offers the typical features of a bathroom shower, often with a seat for comfort.

Sudatorium

A type of steam room in a Roman bath where the high temperature promotes sweating. (refer p. 69)

Temazcal

The temazcal, or “sweat lodge,” is another example of thermal bathing. (Origin Mexico)

Tepidarium/Tepidaria

Relaxation spaces with loungers and beds; the Romans called these areas the tepidarium. (refer p. 83)

Thalasso/Thalassotherapy

From the Greek word thalassa, meaning “sea,” it is the medical use of seawater as a form of therapy for preventive or curative purposes. The term includes seaweed, algae wraps and hydrotherapy.

Thermae/Therma

In Roman times, the thermae, from the Greek word thermos, meaning “hot,” were facilities for bathing; the term usually refers to the large public bathing complexes. Most Roman cities had at least one such building, which were centers not only for bathing, but socializing. (Origin Latin)

Thermal Bathing

Thermal bathing is commonly associated with naturally hot water, rich in mineral salts, iodine and gases. The place is often referred to as a spa, which is traditionally used to mean a place where the water is believed to have special health-giving properties.

Thermal Suite

The collection of thermal treatments in a spa is commonly called the thermal suite.

Vichy Shower

A Vichy shower is a horizontal series of showerheads forming a “rain bar” over a waterproof, cushioned treatment table. (refer p. 120)

Vitality Pool

A vitality pool is the generic name for what people commonly refer to as a “Jacuzzi” (a brand name that is synonymous with pools with water jets). Vitality pools offer a mini-hydrotherapy experience. (refer p. 134)

Water Cure

The use of water as a form of physical therapy, e.g., the Kneipp walk, which uses a mix of hot and cold water to stimulate the circulation of blood. Pebbles on the bottom of the stream/walkway massage the feet and the alternation of hot and cold baths stimulate circulation to all parts of the body.

Watsu®

These are pools designed specifically for Watsu massage, a gentle form of body therapy performed in warm water. (refer p. 139)

Whirlpool Tub

This is a bath large enough for several persons sitting down to be massaged by underwater jets.

Hydrothermal Guide

Sponsors



Accor

www.accor.com

Accor is a world-leading hospitality group consisting of more than 5,300 properties and 10,000 food and beverage venues throughout 110 countries. The group has one of the industry's most diverse and fully integrated hospitality ecosystems encompassing more than 40 luxury, premium, midscale and economy hotel brands, entertainment and nightlife venues, restaurants and bars, branded private residences, shared accommodation properties, concierge services, co-working spaces and more. Accor boasts an unrivaled portfolio of distinctive brands and approximately 260,000 team members worldwide.



Barr & Wray

www.barrandwray.com

With 60 years of experience, Barr + Wray is a globally recognized, world-class designer and supplier of all pool + spa-related equipment. Services range from technical engineering design of pools + spas, bespoke stainless-steel massage features and bespoke thermal cabins. Barr + Wray's highly innovative interior design team works on all levels of pool + spa projects, providing a fully coordinated and integrated spa interior design solution to match client requirements.



Design for Leisure

www.designforleisure.com

Specialists in the design and build of award-winning hydrothermal spa and wellness environments, DFL has been creating high-end, turnkey wet spa areas for both commercial wellness projects and luxury homes for over three decades. With offices in the UK and the USA, DFL provides complete spa design, hydrothermal technical design, supply and build, and service and training. DFL works closely with all stakeholders to develop a hydrothermal area that fits a project's budget, wellness program, and available real estate, all while keeping a keen eye on expenditure and profitability.



Dornbracht

www.dornbracht.com

Dornbracht is a leading specialist supplier of superior designer fittings and accessories for bathroom, spa and kitchen. With clearly defined design principles for a lasting product design and a consistent focus on user needs, Dornbracht has transformed the bathroom and kitchen into living spaces. The manufacturer is famous worldwide for its design and architectural expertise and quality of manufacture at the highest level and underlines its leadership aspirations with the brand claim “Leading Designs for Architecture”

GHARIENIGROUP

Gharieni Group

www.gharieni.com

Thirty years of innovation and German engineering are the cornerstones of the Gharieni Group’s premium global brands - known for its mind/body wellness technologies - and premium quality medical, spa, and wellness equipment. Today, the group is positioned as a leading player in the wellness industry – creating unparalleled guest experiences for the most discerning wellness seeker. Present in more than 120 countries worldwide, Gharieni counts some of the most prestigious names in luxury hospitality, medical wellness, and luxury residential as clients.



Hilton

www.hilton.com

Hilton is a leading global hospitality company with a portfolio of 22 world-class brands comprising more than 7,500 properties and nearly 1.2 million rooms, in 126 countries and territories. Hilton has welcomed over 3 billion guests in its more than 100-year history, was named the No. 1 World’s Best Workplace by Great Place to Work and Fortune and has been recognized as a global leader on the Dow Jones Sustainability Indices for seven consecutive years.



HygroMatik

www.hygromatik.com

HygroMatik develops, produces and distributes energy-efficient and flexible solutions for air humidification and steam generation for spa applications. For over 53 years, HygroMatik has offered a range of products for commercial HVAC, process HVAC, and industrial HVAC. The company has been supplying steam bath generators for spa and wellness applications for over 35 years. The company values sustainability and its products are designed and built for longevity.



Kemitron

www.kemitron.com

Kemitron, based in Wendlingen, Germany, is a prominent manufacturer and supplier to the spa, sauna, and wellness industry. Their diverse product line encompasses Technico, cutting-edge technology solutions; Aromee, an array of luxurious fragrances; Pflege, specializing in skincare products; and Pure, top-quality disinfectants and care cleaners. With a legacy spanning decades, Kemitron's commitment to excellence and innovation remains unwavering. As a family-owned enterprise, the company prioritizes quality, reliability, and customer satisfaction.



KLAFS

www.klafs.com

Headquartered in Germany and founded in 1928, KLAFS is an award-winning, world-leading trendsetter in wellness and spa. The company is recognized as offering innovative, one-stop solutions for unique spa design and custom-made products. KLAFS' product range includes custom-made and prefabricated thermal spa equipment, including saunas, infrared therapy, steam rooms, hammams, ice and snow rooms and relaxation loungers. With a focus on sustainability and eco-friendliness, KLAFS is a reliable partner for residential and commercial clients globally.



LUX ELEMENTS

www.luxelements.com

Providers of system-oriented solutions for wet room areas, LUX ELEMENTS is an experienced specialist in the production of polystyrene hard foam and its further processing into secure substrates for bathrooms and wellness areas. This includes products for the design and installation of individual spa and wellness features in both the public and private sector.



SnowBOX

www.snow-industries.com

As a leading technical snow company, SnowBOX offers 365-day snow solutions for events, spas, sports and other industries. Regardless of the ambient conditions, at temperatures below or above 0°C, SnowBOX can advise and offer a solution to meet the needs of customers. SnowBOX develops special snowmaking technologies and provides SNOW-INDUSTRIES products for snow rooms and cabins, snow showers, snow fountains, outdoor snow areas, therapeutic snowmaking etc.



Sommerhuber

www.sommerhuber.com

Austria-based Sommerhuber has been manufacturing ceramics for fireplaces since 1491. Today, their unique Heat Storing Ceramics are part of leading spas and thermal experiences across the globe. The ceramic manufactory combines the expertise of traditional ceramic tile manufacturing with contemporary spa design requirements. The product range includes ergonomically shaped benches, heated loungers, hammam tables, and foot basins. Mild ceramic infrared heat has a calming effect and provides for ultimate comfort and relaxation.

TECHNOALPIN INDOOR

TechnoAlpin Indoor

www.indoor.technoalpin.com

Founded in 1990, TechnoAlpin is the world leader in snowmaking systems. With its Indoor snow division, TechnoAlpin combines its fascination for snow with holistic well-being to create something completely unique. TechnoAlpin Indoor offers expert consultation for indoor snow concepts, assisting customers with the integration of snow for wellbeing experiences in the initial design phase of spa concepts, providing individualized solutions for any business wishing to elevate a guest's spa experience.

UNBESCHIEDEN
Baden-Baden



Unbescheiden

www.unbescheiden.com

Since 1869, Unbescheiden GmbH has been developing high-quality, unique solutions for the spa, wellness, therapy and care sectors. The company's product line includes hydrotherapy tubs, dry floatation beds for body wraps, showers and beds for dry hydromassage. Unbescheiden's experience is reflected in the sophisticated functionality, numerous application possibilities and easy operability of its equipment. Unbescheiden, based in Baden-Baden, is appreciated by customers worldwide.

WDT
Werner Dosiertechnik

WDT

www.werner-dosiertechnik.com

WDT was founded by Dietmar Werner in 1985 and develops and produces high-quality control and dosing systems for swimming pools and hydrothermal wellness facilities. The product range of wellness systems is a compilation of WDT's concepts as well as collaborative solutions created with partners from all over the world. These include experience showers, techniques for steam rooms and saunas, salt nebulization systems, aromatization systems and control systems for complete wellness facilities.



**GLOBAL WELLNESS
INSTITUTE™**
EMPOWERING WELLNESS WORLDWIDE

**Global Wellness Institute
333 S.E. 2nd Avenue, Suite 2045
Miami, FL 33131 United States**

www.globalwellnessinstitute.org